

**STRATA PLAN OF LOT E, BLOCK 30,  
DISTRICT LOT 185, GROUP 1,  
NEW WESTMINSTER DISTRICT,  
PLAN 22868.**

**STRATA PLAN LMS 3963**

INTEGRATED SURVEY AREA No. 31, NAD83.  
CITY OF VANCOUVER  
B.C.G.S. 92G.025

DEPOSITED AND REGISTERED IN THE LAND  
TITLE OFFICE AT NEW WESTMINSTER, B.C.

THIS 9<sup>TH</sup> DAY OF AUG 1999.

*JIM SMALL / REC TS*  
Deputy Registrar  
REF. # BN 212808 TO  
BN 213105

Scale 1:500  
0 5 10 20  
ALL DISTANCES ARE IN METRES  
AND DECIMALS THEREOF.

THE VENUS

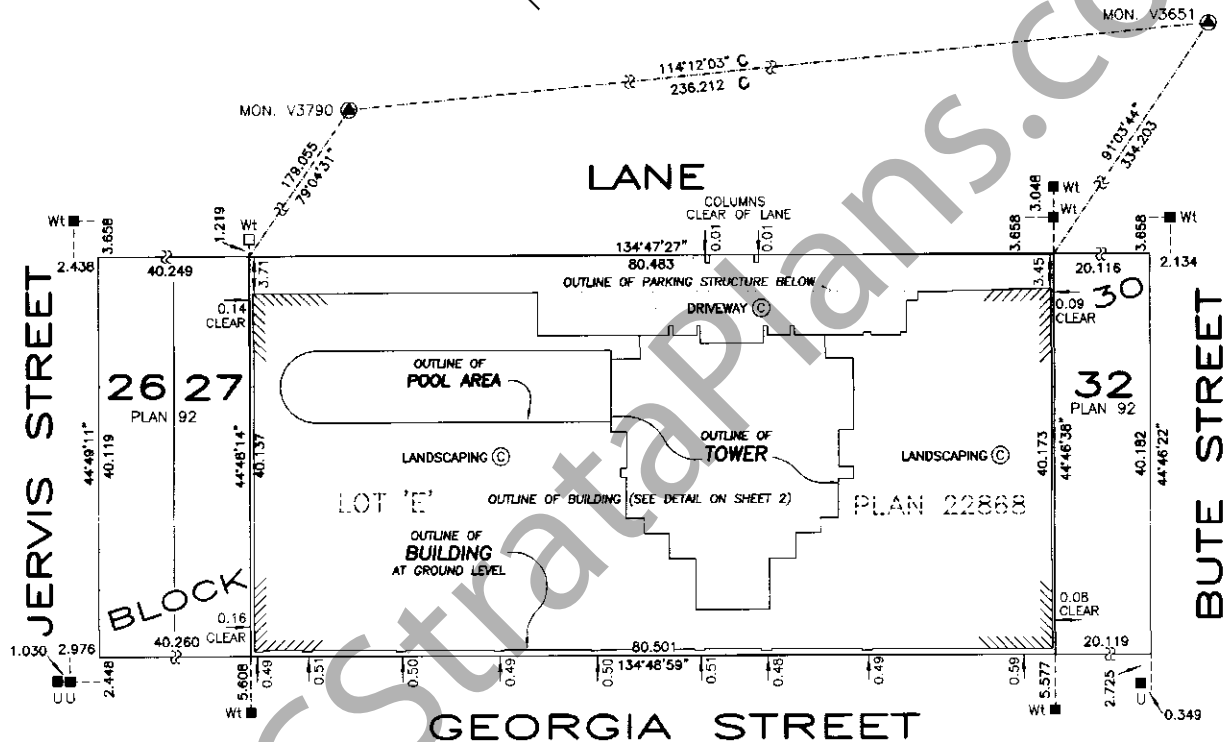

**LEGEND**

GRID BEARINGS ARE DERIVED FROM OBSERVATIONS  
BETWEEN CONTROL MONUMENTS V3790 AND V3651.  
INTEGRATED SURVEY AREA # 31, NAD83.  
THIS PLAN SHOWS GROUND LEVEL MEASURED DISTANCES.  
PRIOR TO COMPUTATION OF U.T.M. COORDINATES.  
MULTIPLY BY A COMBINED SCALE FACTOR OF 0.9996010.

- ⊙ - DENOTES COMMON PROPERTY
- U - DENOTES UNREGISTERED
- Wt - DENOTES WITNESS
- ⊙ - DENOTES CONTROL MONUMENT
- - DENOTES LEAD PLUG FOUND

THE ADDRESS FOR SERVICE  
OF DOCUMENTS ON THE  
STRATA CORPORATION IS:-  
THE OWNER, STRATA PLAN  
LMS 3963  
~~MCCARTHY TETRAULT~~  
1300 777 BUNSMAR STREET  
VANCOUVER, B.C.  
V7Y 4K2

CIVIC ADDRESSES ARE AS FOLLOWS:-  
UNITS: 301-310, 401-410, 501-510,  
601-610, 701-710, 801-810, 901-910,  
1001-1010, 1101-1110, 1201-1210,  
1501-1510, 1601-1610, 1701-1710,  
1801-1810, 1901-1910, 2001-2010,  
2101-2110, 2201-2210, 2301-2310,  
2401-2410, 2501-2510, 2601-2610,  
2701-2709, 2801-2809, 2901-2909,  
3001-3009, 3101-3109, 3201-3209,  
3301-3309, 3401-3405, 3501-3505,  
AND 3601-3605, ALL OF  
1239 WEST GEORGIA STREET  
VANCOUVER, B.C.

"FOR MAILING ADDRESS OF STRATA  
CORPORATION SEARCH THE STRATA  
PLAN GENERAL INDEX."

I, J. NEIL BENNETT OF NORTH VANCOUVER  
A BRITISH COLUMBIA LAND SURVEYOR,  
HEREBY CERTIFY THAT THE BUILDING,  
ERECTED ON THE PARCEL DESCRIBED  
ABOVE IS WHOLLY WITHIN THE EXTERNAL  
BOUNDARIES OF THAT PARCEL.

BENNETT & ASSOCIATES  
B.C. LAND SURVEYORS  
#201 - 275 FELL AVENUE  
NORTH VANCOUVER, B.C.  
V7P 3R5  
PH. 980-4868  
FX. 980-5856  
FILE: C:\PK3\11963\ST11963-1F.DWG

THIS PLAN LIES WITHIN  
THE GREATER VANCOUVER  
REGIONAL DISTRICT

DATED THIS 24<sup>TH</sup> DAY OF  
June 1999  
*J. Neil Bennett*  
B.C.L.S.

FILED  
LMS3963  
M47598  
2007-01-18-16-38:23-972659



**CONDOMINIUM ACT**

**STRATA PLAN LMS 3963**

OWNER :

B.P.Y.A. 130 HOLDINGS LTD.  
INC.No. 355168

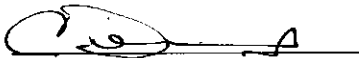

AUTHORIZED SIGNATORY  
MICHAEL DE COTTIS



AUTHORIZED SIGNATORY  
WITNESS AS TO BOTH SIGNATURES  
PETER PAGNAN  
1300-777 DUNSMUIR STREET  
VANCOUVER, B.C. V7Y 1K2  
OCCUPATION OF WITNESS

LAWYER  
ADDRESS OF WITNESS

MORTGAGEE :

FINOVA (CANADA) CAPITAL CORPORATION  
INC.No. 42774A

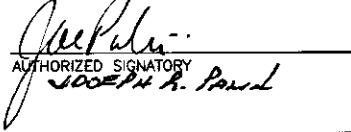

AUTHORIZED SIGNATORY  
JOSEPH A. PAUL

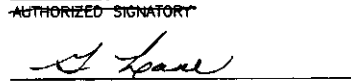

AUTHORIZED SIGNATORY  
WITNESS AS TO BOTH SIGNATURES  
GAVIN LAMBIE  
30 FLE 257-4AVE SW  
CALGARY AB T2P 4K7  
OCCUPATION OF WITNESS

SECRETARY  
ADDRESS OF WITNESS

MORTGAGEE :

BCMP MORTGAGE INVESTMENT CORPORATION  
INC.No. 40387A

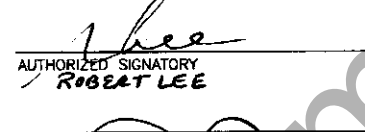

AUTHORIZED SIGNATORY  
ROBERT LEE

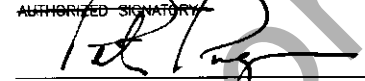

AUTHORIZED SIGNATORY  
WITNESS AS TO BOTH SIGNATURES  
PETER PAGNAN  
1300-777 DUNSMUIR STREET  
VANCOUVER, B.C. V7Y 1K2  
OCCUPATION OF WITNESS

LAWYER  
ADDRESS OF WITNESS

MORTGAGEE :

BANK OF MONTREAL

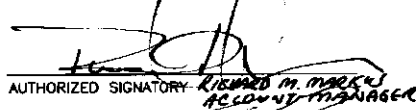

AUTHORIZED SIGNATORY  
RICHARD M. MARKS  
ACCOUNT MANAGER



AUTHORIZED SIGNATORY  
GORDON L. LEIGHTON  
ACCOUNT MANAGER

  
WITNESS AS TO BOTH SIGNATURES  
TERRI ENG  
CUSTOMER SERVICE OFFICER  
OCCUPATION OF WITNESS  
6TH FLOOR, 385 BURNARD ST.  
VANCOUVER, B.C. V7X 1L5  
ADDRESS OF WITNESS

THE CITY OF VANCOUVER, REGISTERED OWNER OF EASEMENT AND INDEMNITY AGREEMENTS 252289M, 254066M, GD70396, GD70397, AND OF COVENANTS BE274974, BL289882, AND OF STATUTORY RIGHT OF WAY BL289883, HEREBY CONSENT TO THE DEPOSIT OF THIS PLAN.



AUTHORIZED SIGNATORY

AUTHORIZED SIGNATORY

**STATUTORY DECLARATION**

I, THE UNDERSIGNED DO SOLEMNLY DECLARE THAT:

- 1) I, THE UNDERSIGNED AM THE DULY AUTHORIZED AGENT OF THE OWNER / DEVELOPER.
- 2) THE STRATA PLAN IS FOR RESIDENTIAL USE ONLY.

I MAKE THIS SOLEMN DECLARATION CONSCIENTIOUSLY BELIEVING IT TO BE TRUE AND KNOWING IT IS OF THE SAME FORCE AND EFFECT AS IF MADE UNDER OATH.

  
MICHAEL DE COTTIS

DECLARED BEFORE ME AT VANCOUVER  
IN THE PROVINCE OF BRITISH COLUMBIA  
THIS 7th DAY OF JULY, 1999.

  
A COMMISSIONER FOR TAKING AFFIDAVITS WITHIN THE PROVINCE OF BRITISH COLUMBIA Peter Pagnan

ACCEPTED AS TO FORMS 1 AND 2.  
THIS 5 DAY OF August, 1999.

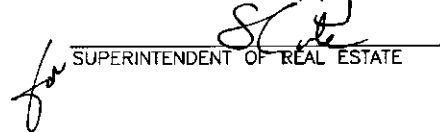
  
SUPERINTENDENT OF REAL ESTATE

**NEW DEVELOPMENT CERTIFICATE**

I, J. NEIL BENNETT OF NORTH VANCOUVER A BRITISH COLUMBIA LAND SURVEYOR, HEREBY CERTIFY THAT THE BUILDING, SHOWN IN THIS STRATA PLAN HAS

NOT AS OF THE 24<sup>th</sup> DAY OF June, 1999.  
BEEN PREVIOUSLY OCCUPIED,

DATED THIS 24<sup>th</sup> DAY OF June, 1999.

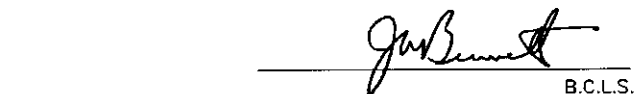
  
B.C.L.S.

**CONDOMINIUM ACT**

**STRATA PLAN LMS 3963**

**SCHEDULES**

**SCHEDULES**

LOT NUMBER	SHEET NUMBER	FORM 1	FORM 2
		SCHEDULE OF UNIT ENTITLEMENT UNIT ENTITLEMENT	SCHEDULE OF INTEREST UPON DESTRUCTION INTEREST UPON DESTRUCTION
1	16, 39	614	1629
2	16, 39	795	2089
3	16, 38	675	1759
4	16, 37	814	2159
5	16, 37	610	1629
6	16, 37	427	1209
7	16, 37	926	2529
8	16, 38	662	1799
9	16, 39	898	2509
10	16, 39	419	1209
11	17, 39	614	1649
12	17, 39	797	2109
13	17, 38	675	1779
14	17, 37	815	2179
15	17, 37	609	1649
16	17, 37	427	1219
17	17, 37	926	2569
18	17, 38	673	1819
19	17, 39	898	2539
20	17, 39	419	1219
21	17, 39	614	1669
22	17, 39	797	2129
23	17, 38	675	1799
24	17, 37	816	2199
25	17, 37	609	1669
26	17, 37	427	1229
27	17, 37	926	2599
28	17, 38	671	1839
29	17, 39	898	2569
30	17, 39	419	1229
31	18, 39	615	1889
32	18, 39	797	2149
33	18, 38	675	1819
34	18, 37	816	2219
35	18, 37	609	1689
36	18, 37	427	1239
37	18, 37	926	2629
38	18, 38	672	1859
39	18, 39	898	2599
40	18, 39	419	1239
41	18, 39	615	1709
42	18, 39	797	2169
43	18, 38	675	1839
44	18, 37	816	2239
45	18, 37	609	1709
46	18, 37	427	1249
47	18, 37	926	2659
48	18, 38	674	1879
49	18, 39	898	2629
50	18, 39	419	1249

**SCHEDULES**

LOT NUMBER	SHEET NUMBER	FORM 1	FORM 2
		SCHEDULE OF UNIT ENTITLEMENT UNIT ENTITLEMENT	SCHEDULE OF INTEREST UPON DESTRUCTION INTEREST UPON DESTRUCTION
51	19, 39	612	1729
52	19, 39	795	2189
53	19, 38	676	1859
54	19, 37	816	2259
55	19, 37	609	1729
56	19, 37	427	1259
57	19, 37	926	2689
58	19, 38	674	1899
59	19, 39	898	2659
60	19, 39	419	1259
61	19, 39	612	1749
62	19, 39	795	2209
63	19, 38	675	1879
64	19, 37	816	2279
65	19, 37	609	1749
66	19, 37	427	1269
67	19, 37	926	2719
68	19, 38	674	1919
69	19, 39	898	2689
70	19, 39	419	1269
71	20, 39	612	1769
72	20, 39	795	2229
73	20, 38	675	1899
74	20, 37	816	2299
75	20, 37	609	1769
76	20, 37	427	1279
77	20, 37	926	2749
78	20, 38	674	1939
79	20, 39	898	2719
80	20, 39	419	1279
81	20, 39	612	1789
82	20, 39	795	2249
83	20, 38	676	1919
84	20, 37	816	2319
85	20, 37	609	1789
86	20, 37	427	1289
87	20, 37	926	2779
88	20, 38	673	1959
89	20, 39	898	2749
90	20, 39	419	1289
91	21, 39	612	1809
92	21, 39	795	2269
93	21, 38	676	1939
94	21, 37	816	2339
95	21, 37	609	1809
96	21, 37	427	1299
97	21, 37	926	2809
98	21, 38	673	1979
99	21, 39	898	2779
100	21, 39	419	1299

DATED THIS 24<sup>th</sup> DAY OF June, 1999.

*gub*

CONDOMINIUM ACT

STRATA PLAN LMS 3963

SCHEDULES

SCHEDULES

SCHEDULES

LOT NUMBER	SHEET NUMBER	FORM 1	FORM 2
		SCHEDULE OF UNIT ENTITLEMENT	SCHEDULE OF INTEREST UPON DESTRUCTION
		UNIT ENTITLEMENT	INTEREST UPON DESTRUCTION
101	21, 39	612	1839
102	21, 39	795	2289
103	21, 38	675	1969
104	21, 37	816	2359
105	21, 37	609	1839
106	21, 37	427	1309
107	21, 37	926	2859
108	21, 38	673	2019
109	21, 39	898	2819
110	21, 39	419	1309
111	22, 39	612	1859
112	22, 39	795	2309
113	22, 38	675	1989
114	22, 37	816	2379
115	22, 37	609	1859
116	22, 37	427	1319
117	22, 37	926	2889
118	22, 38	676	2039
119	22, 39	934	2849
120	22, 39	434	1319
121	22, 36	622	1879
122	22, 36	808	2329
123	22, 35	675	2009
124	22, 34	816	2399
125	22, 34	609	1879
126	22, 34	427	1329
127	22, 34	926	2929
128	22, 35	675	2049
129	22, 36	898	2869
130	22, 36	419	1329
131	23, 36	612	1889
132	23, 36	795	2349
133	23, 35	675	2029
134	23, 34	816	2419
135	23, 34	609	1899
136	23, 34	427	1339
137	23, 34	926	2959
138	23, 35	674	2069
139	23, 36	928	2899
140	23, 36	438	1339
141	23, 36	615	1919
142	23, 36	794	2369
143	23, 35	675	2049
144	23, 34	816	2439
145	23, 34	609	1919
146	23, 34	427	1349
147	23, 34	926	2989
148	23, 35	675	2089
149	23, 36	931	2929
150	23, 36	435	1349

LOT NUMBER	SHEET NUMBER	FORM 1	FORM 2
		SCHEDULE OF UNIT ENTITLEMENT	SCHEDULE OF INTEREST UPON DESTRUCTION
		UNIT ENTITLEMENT	INTEREST UPON DESTRUCTION
151	24, 36	622	1929
152	24, 36	813	2389
153	24, 35	677	2069
154	24, 34	816	2459
155	24, 34	609	1929
156	24, 34	427	1359
157	24, 34	926	3019
158	24, 35	681	2109
159	24, 36	931	2949
160	24, 36	435	1359
161	24, 36	614	1949
162	24, 36	795	2409
163	24, 35	676	2089
164	24, 34	816	2479
165	24, 34	609	1949
166	24, 34	427	1369
167	24, 34	926	3049
168	24, 35	681	2129
169	24, 36	899	2879
170	24, 36	419	1369
171	25, 36	612	1959
172	25, 36	797	2429
173	25, 35	677	2109
174	25, 34	816	2499
175	25, 34	609	1959
176	25, 34	427	1379
177	25, 34	926	3069
178	25, 35	678	2149
179	25, 36	936	2999
180	25, 36	437	1379
181	25, 36	614	1979
182	25, 36	795	2449
183	25, 35	677	2129
184	25, 34	816	2519
185	25, 34	609	1979
186	25, 34	427	1389
187	25, 34	926	3099
188	25, 35	678	2169
189	25, 36	904	3029
190	25, 36	418	1389
191	26, 36	614	1989
192	26, 36	795	2469
193	26, 35	677	2149
194	26, 34	816	2539
195	26, 34	609	1989
196	26, 34	427	1399
197	26, 34	926	3119
198	26, 35	684	2189
199	26, 36	930	3049
200	26, 36	434	1399

DATED THIS 24<sup>th</sup> DAY OF June, 1999.

*gwb*

B.C.L.S.

FILED INLMS3963 M47598 2007-01-18-16:38:23-972659

**CONDOMINIUM ACT**

**STRATA PLAN LMS 3963**

**SCHEDULES**

**SCHEDULES**

LOT NUMBER	SHEET NUMBER	FORM 1	FORM 2
		SCHEDULE OF UNIT ENTITLEMENT	SCHEDULE OF INTEREST UPON DESTRUCTION
		UNIT ENTITLEMENT	INTEREST UPON DESTRUCTION
201	26, 36	614	2009
202	26, 36	795	2489
203	26, 35	678	2169
204	26, 34	816	2559
205	26, 34	607	2009
206	26, 34	429	1409
207	26, 34	926	3149
208	26, 35	682	2209
209	26, 36	899	3079
210	26, 36	419	1409
211	27, 36	614	2019
212	27, 36	795	2509
213	27, 35	675	2189
214	27, 34	816	2579
215	27, 34	608	2019
216	27, 34	428	1419
217	27, 34	926	3189
218	27, 35	675	2229
219	27, 36	899	3109
220	27, 36	417	1419
221	27, 36	612	2084
222	27, 36	795	2609
223	27, 35	676	2279
224	27, 34	816	2859
225	27, 34	608	2089
226	27, 34	552	1879
227	27,34,35	887	3164
228	27, 36	879	3164
229	27, 36	595	1879
230	28, 36	614	2104
231	28, 36	802	2639
232	28, 35	673	2309
233	28, 34	817	2674
234	28, 34	607	2104
235	28, 34	552	1889
236	28,34,35	886	3179
237	28, 36	878	3179
238	28, 36	589	1889
239	28, 36	614	2124
240	28, 36	795	2659
241	28, 35	676	2339
242	28, 34	816	2699
243	26, 34	808	2129
244	28, 34	550	1899
245	28,34,35	889	3204
246	28, 36	878	3204
247	28, 36	590	1899
248	29, 36	614	2154
249	29, 36	795	2679
250	29, 35	676	2369

**SCHEDULES**

LOT NUMBER	SHEET NUMBER	FORM 1	FORM 2
		SCHEDULE OF UNIT ENTITLEMENT	SCHEDULE OF INTEREST UPON DESTRUCTION
		UNIT ENTITLEMENT	INTEREST UPON DESTRUCTION
251	29, 34	816	2714
252	29, 34	609	2144
253	29, 34	551	1909
254	29,34,35	889	3219
255	29, 36	878	3219
256	29, 36	590	1909
257	29, 36	612	2174
258	29, 36	795	2699
259	29, 35	679	2399
260	29, 34	819	2739
261	29, 34	604	2169
262	29, 34	551	1919
263	29,34,35	889	3244
264	29, 36	878	3244
265	29, 36	590	1919
266	30, 36	612	2184
267	30, 36	795	2719
268	30, 35	677	2429
269	30, 34	818	2754
270	30, 34	608	2184
271	30, 34	550	1929
272	30,34,35	878	3259
273	30, 36	878	3259
274	30, 36	589	1929
275	30, 36	623	2204
276	30, 36	808	2739
277	30, 35	673	2459
278	30, 34	816	2779
279	30, 34	608	2209
280	30, 34	553	1939
281	30,34,35	887	3284
282	30, 36	882	3284
283	30, 36	588	1939
284	31, 36	766	4069
285	31, 35	1211	4949
286	31, 34	670	4179
287	31,34,35	1235	4179
288	31, 36	1174	4069
289	31, 36	775	4269
290	31, 35	1208	5149
291	31, 34	670	4379
292	31,34,35	1232	4379
293	31, 36	1164	4389
294	32, 36	1013	4689
295	32, 35	1366	5449
296	32, 34	1078	4679
297	32,34,35	941	4579
298	32, 36	974	4569
AGGREGATE		211 561	678 317

DATED THIS 24<sup>th</sup> DAY OF June, 1999.

*Jub*

# PARKING LEVEL FIVE FLOOR PLAN

Scale 1:250

ALL DISTANCES ARE IN METRES AND DECIMALS THEREOF.

STRATA PLAN LMS 3963

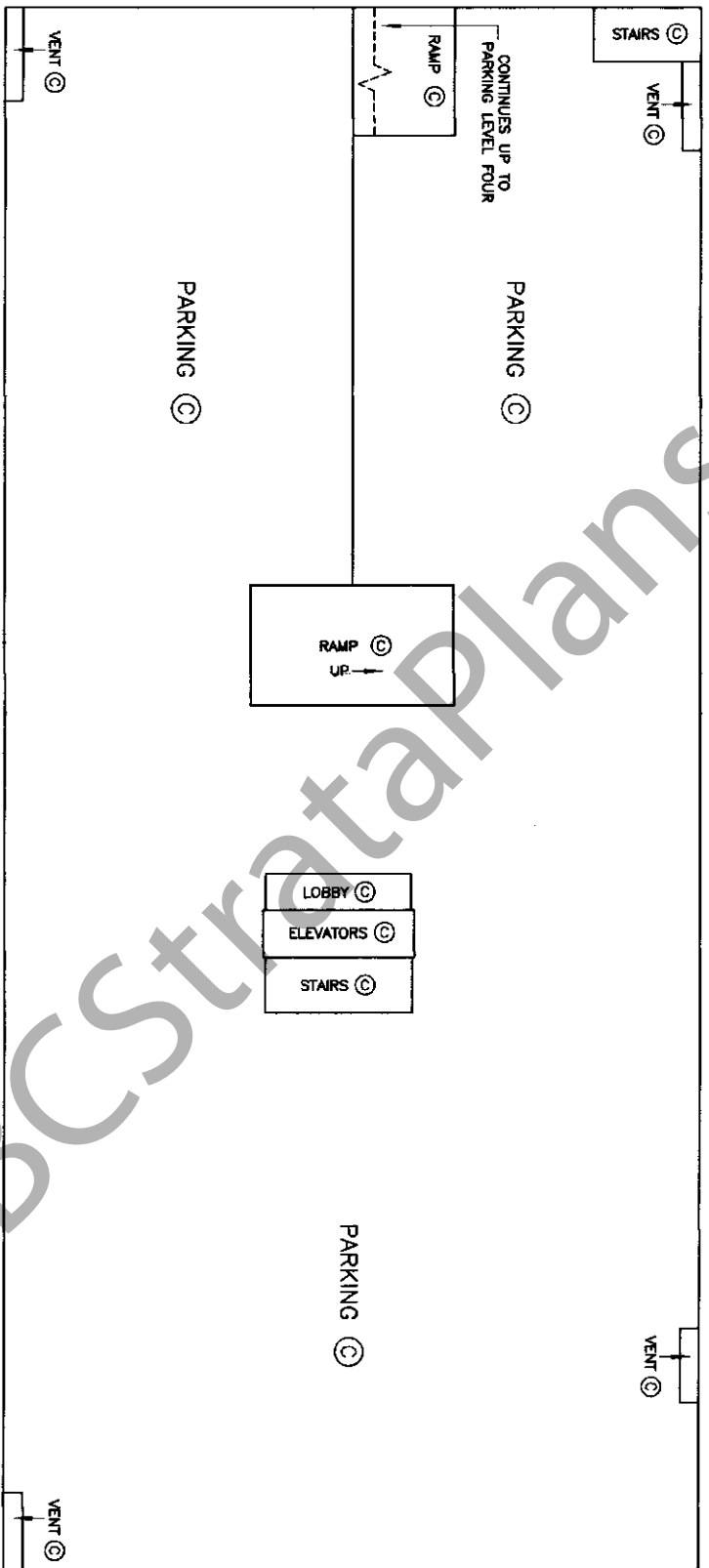

## LEGEND

⊙ - COMMON PROPERTY

FILE: C:\PK3\11963-2F.DWG

DATED THIS 24<sup>th</sup> DAY OF

June, 1999.

*gud*  
B.C.L.S.

www.BCStrataPlans.com

# PARKING LEVEL FOUR FLOOR PLAN

Scale 1:250

ALL DISTANCES ARE IN METRES AND DECIMALS THEREOF.



STRATA PLAN LMS 3963

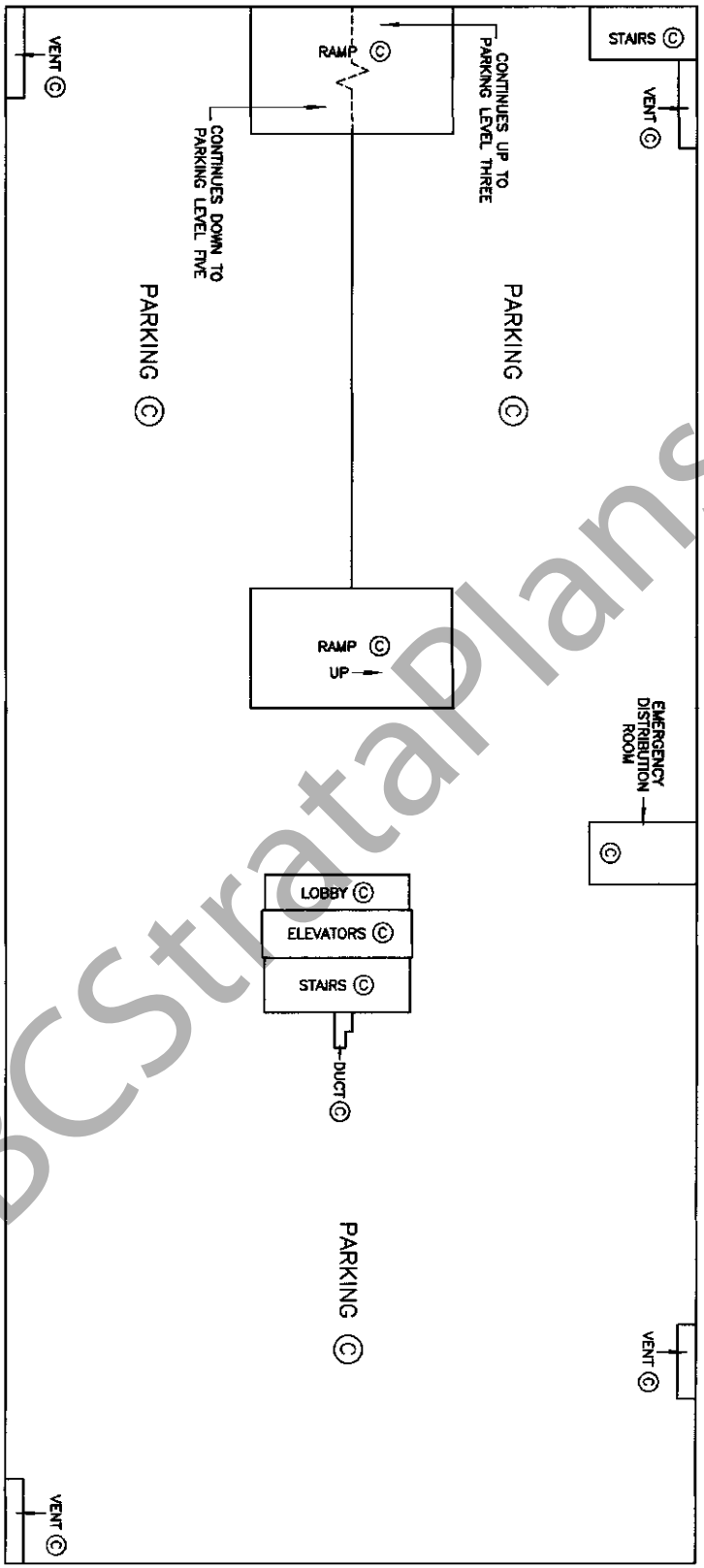

### LEGEND

⊙ - COMMON PROPERTY

FILE: C:\PK3\11963-2F.DWG

DATED THIS 24th DAY OF June, 1999.

  
 GWS  
 B.C.L.S.

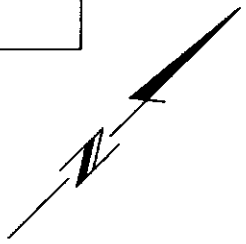



# PARKING LEVEL THREE FLOOR PLAN

Scale 1:250

ALL DISTANCES ARE IN METRES AND DECIMALS THEREOF.

STRATA PLAN LMS 3963

SHEET 9 OF 39 SHEETS

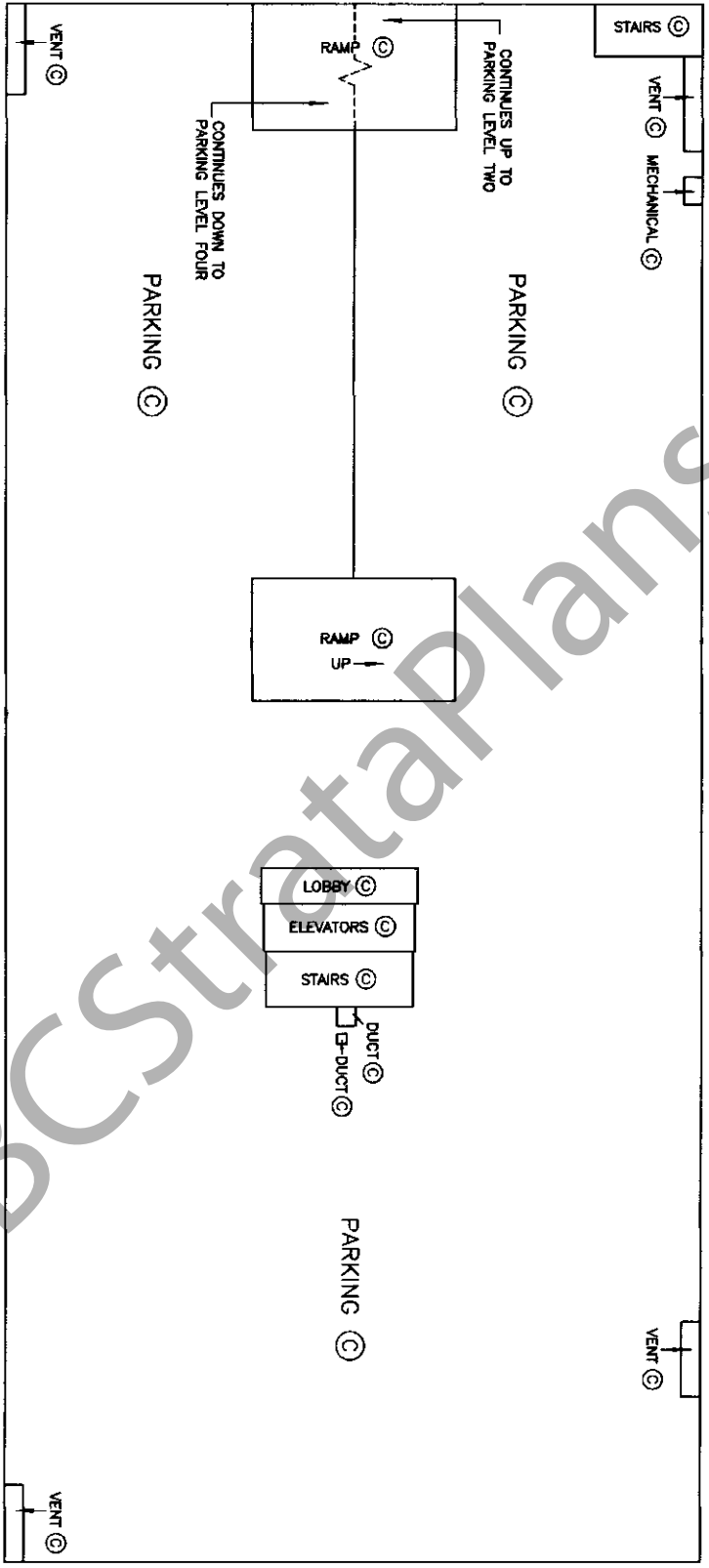

## LEGEND

Ⓢ - COMMON PROPERTY

FILE: G:\PK3\11963-2\F.DWG

DATED THIS 24<sup>th</sup> DAY OF June, 1999.

gwb  
B.C.L.S.

# PARKING LEVEL TWO FLOOR PLAN

Scale 1:250



ALL DISTANCES ARE IN METRES AND DECIMALS THEREOF.

# STRATA PLAN LMS 3963

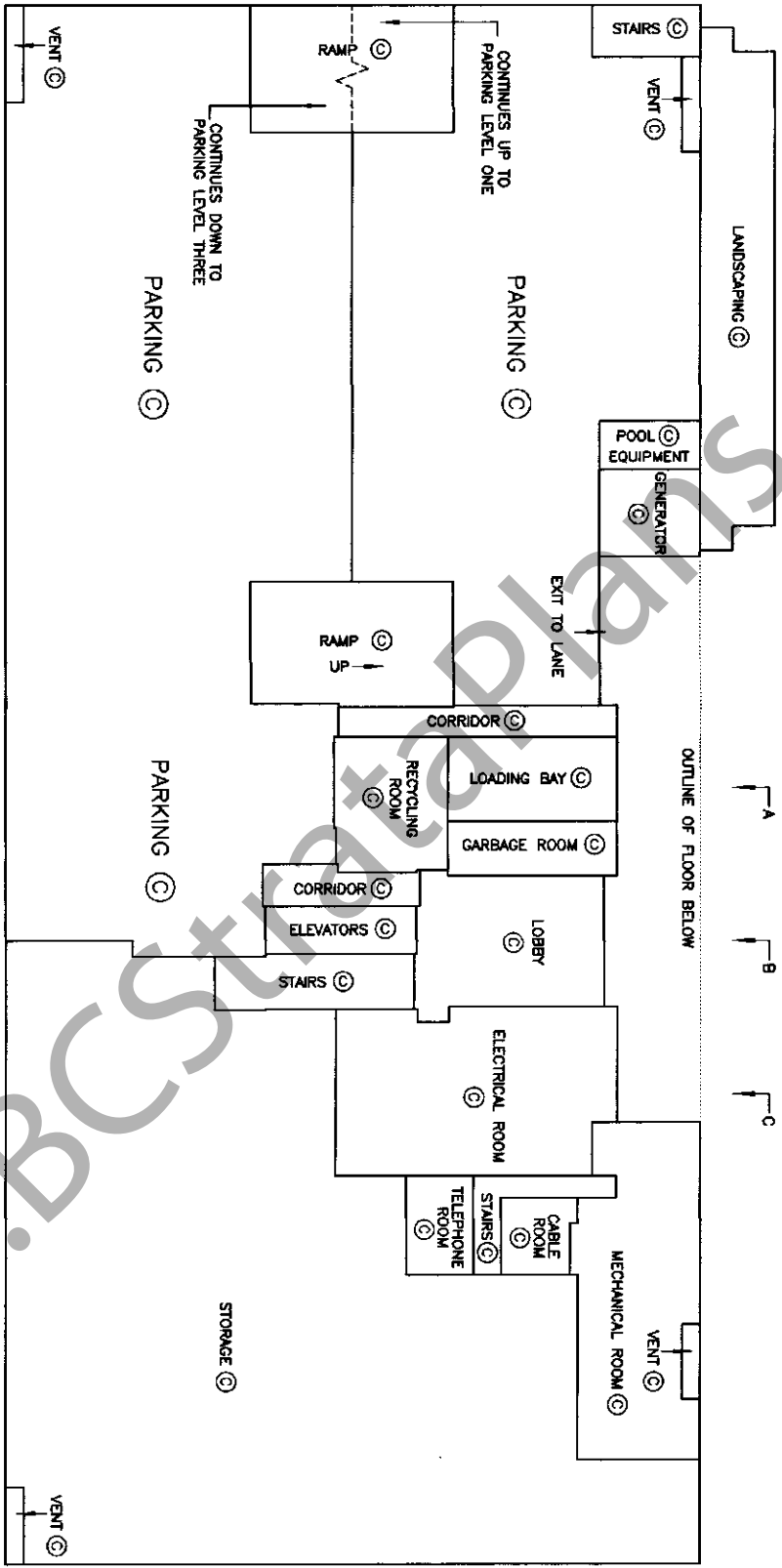

### LEGEND

⊙ - COMMON PROPERTY

FILE: C:\PK3\11963-2F.DWG

DATED THIS 24<sup>th</sup> DAY OF June, 1999.

gwb  
B.C.L.S.

# PARKING LEVEL ONE FLOOR PLAN

Scale 1:250

ALL DISTANCES ARE IN METRES AND DECIMALS THEREOF.

STRATA PLAN LMS 3963

SHEET 11 OF 39 SHEETS

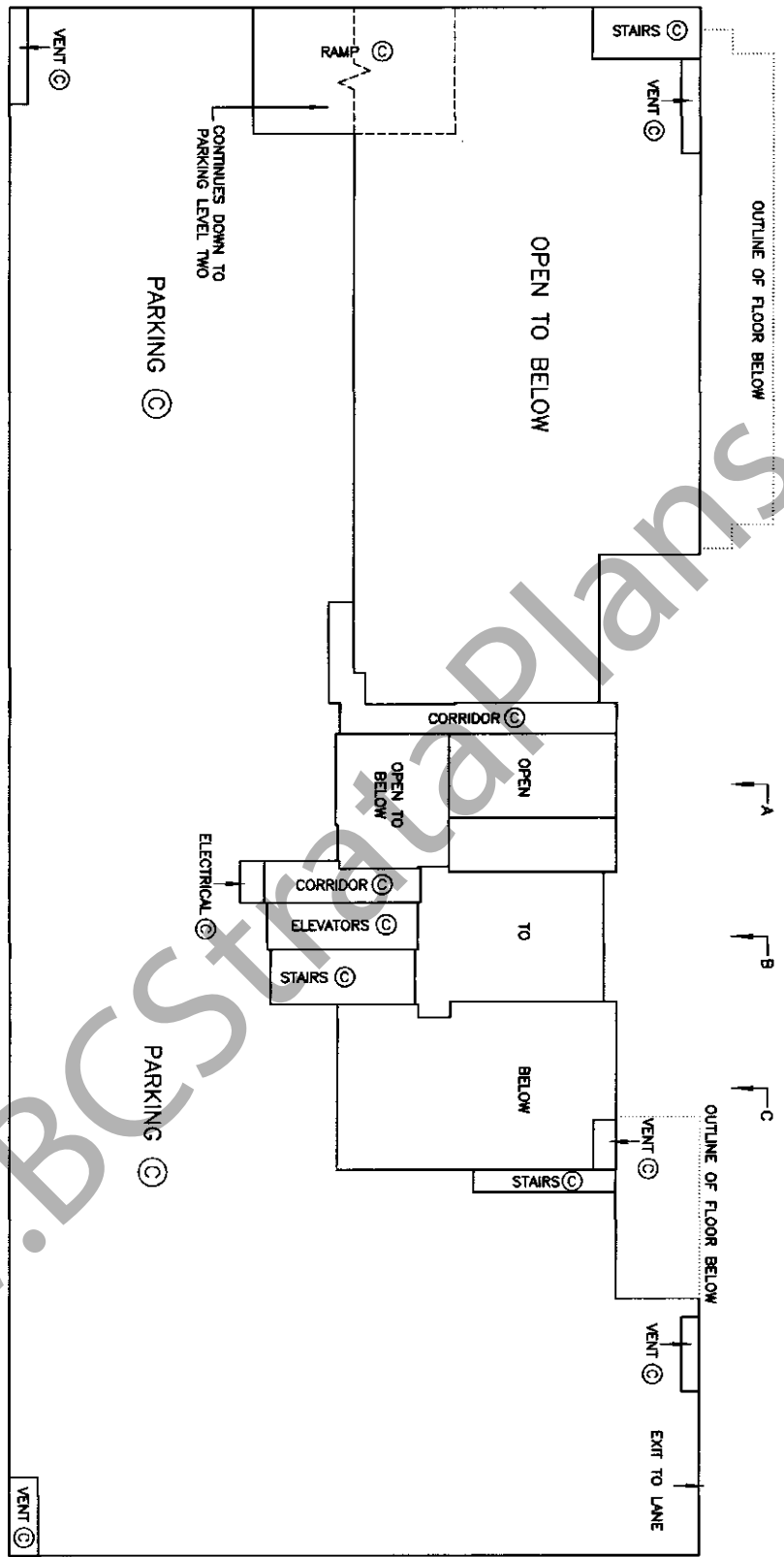

### LEGEND

⊙ - COMMON PROPERTY

FILE: C:\PK3\11963-2F.DWG

DATED THIS 24th DAY OF

1999.

B.C.L.S.

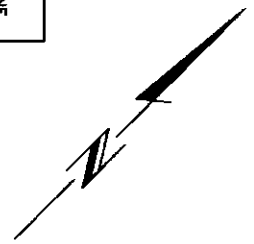

# LEVEL ONE FLOOR PLAN

Scale 1:250



ALL DISTANCES ARE IN METRES AND DECIMALS THEREOF.

# STRATA PLAN LMS 3963

SHEET 12 OF 39 SHEETS

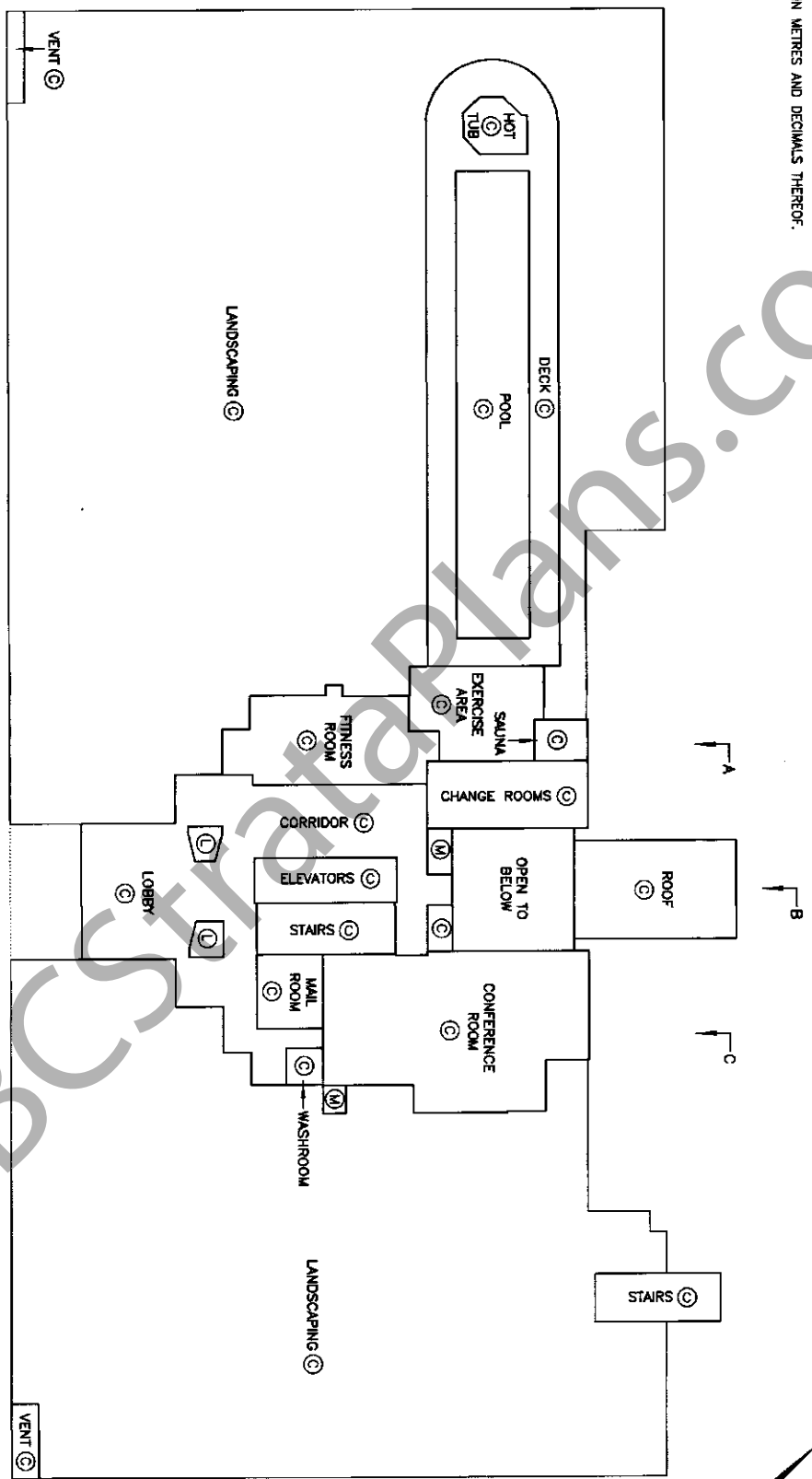

- LEGEND**
- (M) - DENOTES MECHANICAL COMMON PROPERTY
  - (L) - DENOTES ELECTRICAL COMMON PROPERTY
  - (C) - COMMON PROPERTY

FILE: C:\PK3\11963-2F.DWG

DATED THIS 24<sup>th</sup> DAY OF June, 1999.

*gus*  
B.C.L.S.

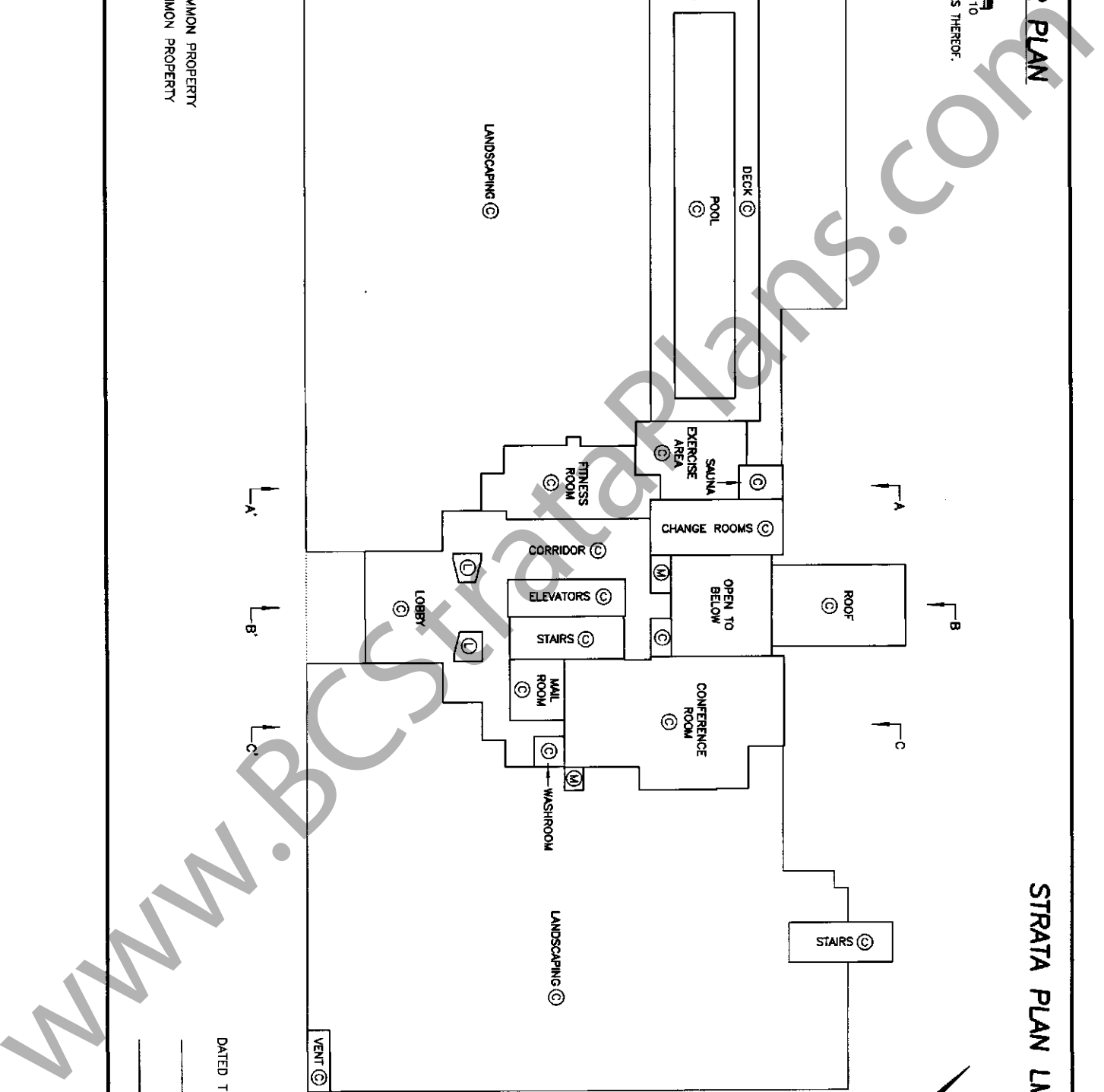

# LEVEL TWO FLOOR PLAN

Scale 1:250



STRATA PLAN LMS 3963

SHEET 13 OF 39 SHEETS

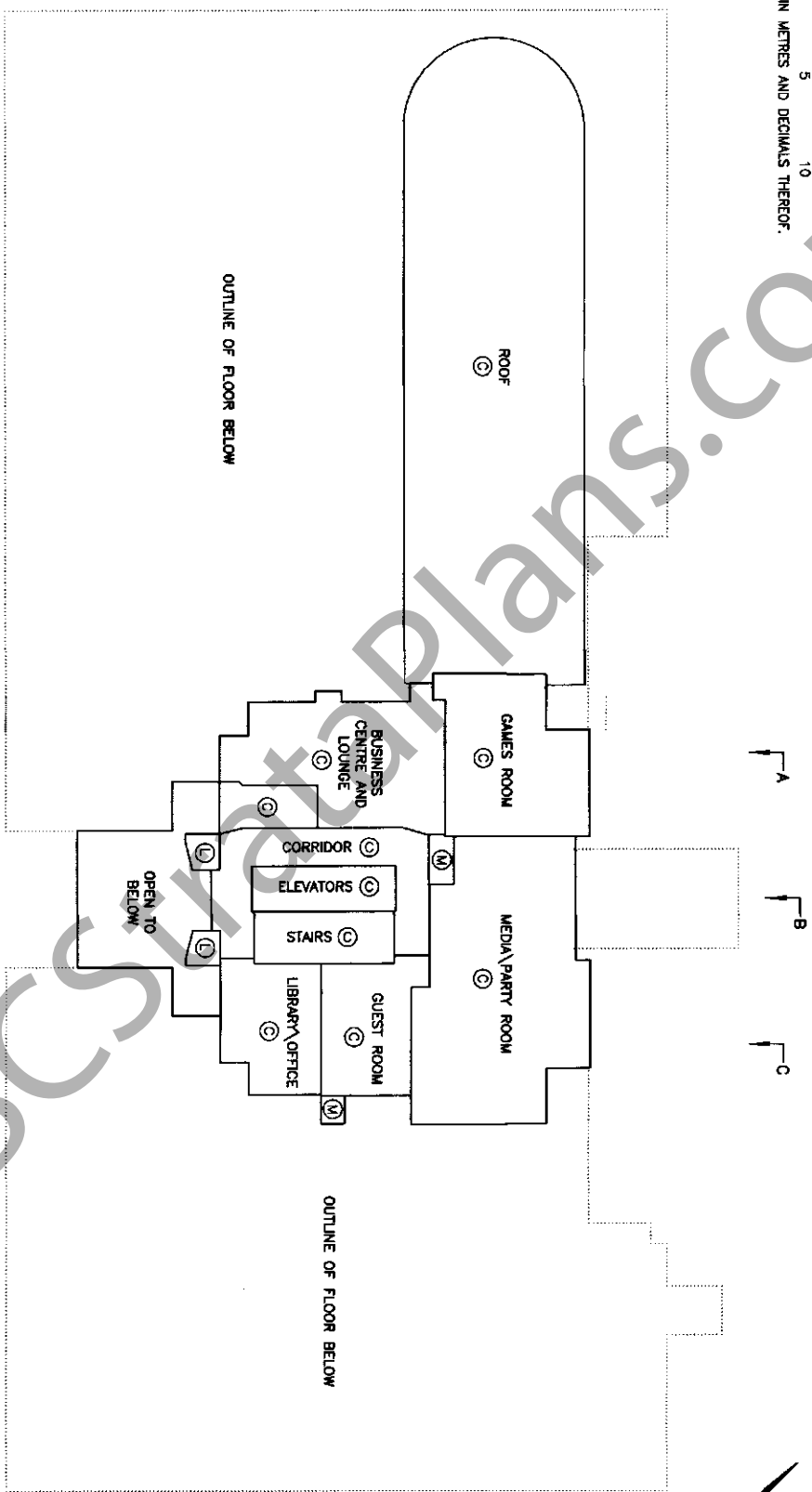

### LEGEND

- (M) - DENOTES MECHANICAL COMMON PROPERTY
- (E) - DENOTES ELECTRICAL COMMON PROPERTY
- (C) - COMMON PROPERTY

FILE: C:\PK3\11963-2F.DWG

DATED THIS 24<sup>th</sup> DAY OF June, 1999.

*gub*

B.C.L.S.

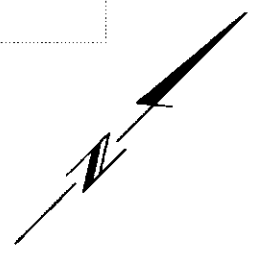

**DETAILS**

**STRATA PLAN LMS 3963**

DETAIL SHOWING DEFLECTION ANGLES TYPICAL FOR SLs 8, 18, 28, 38, 48, 58, 68, 78, 88, 98, 108, 118, 128, 138, 148, 158, 168, 178, 188, 198, 208, AND 218.

Not To Scale

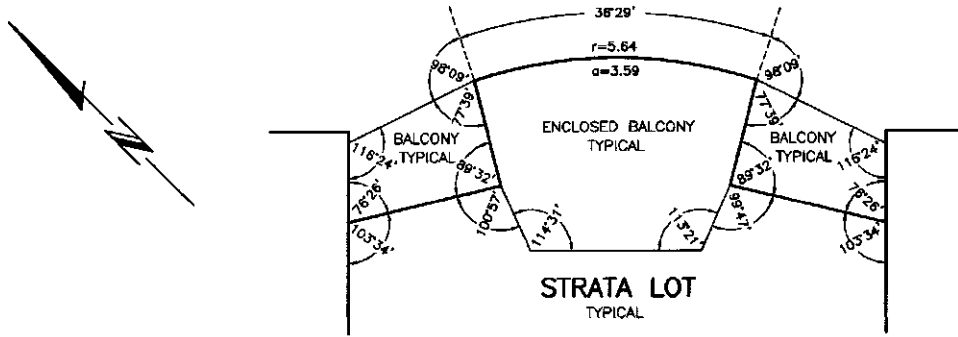

DETAIL SHOWING DEFLECTION ANGLES TYPICAL FOR SLs 3, 13, 23, 33, 43, 53, 63, 73, 83, 93, 103, 113, 123, 133, 143, 153, 163, 173, 183, 193, 203, 213, 223, 232, 241, 250, 259, 268, AND 277.

Not To Scale

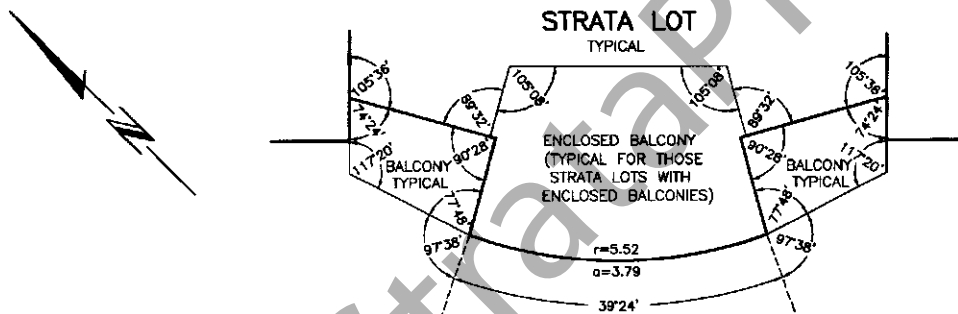

DETAIL SHOWING DEFLECTION ANGLES TYPICAL FOR SLs 227, 228, 236, 237, 245, 246, 254, 255, 263, 264, 272, 273, 281, AND 282.

Not To Scale

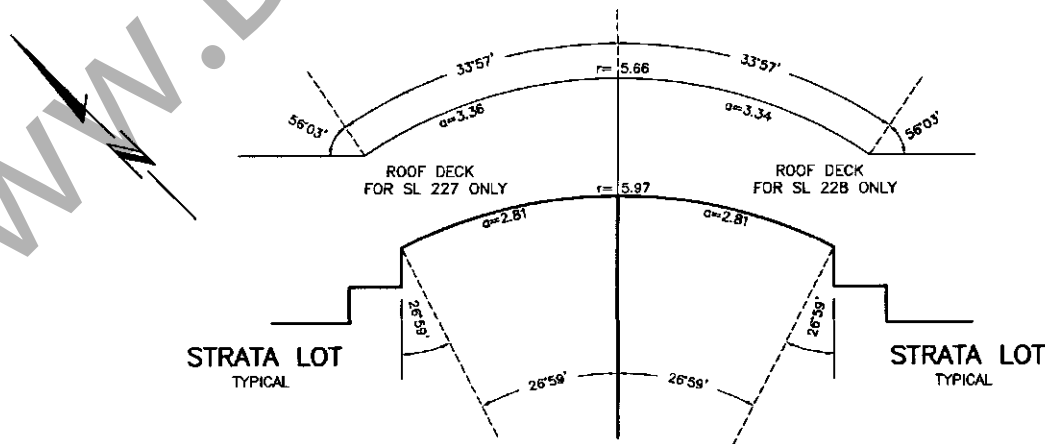

**LEGEND**

SL - DENOTES STRATA LOT  
FILE: C:\PK3\11963-3F.DWG

DATED THIS 24<sup>th</sup> DAY OF  
June, 1999.  
gwb  
B.C.L.S.

FILED  
L\LMMS3963  
M47598 2007-01-18-16:38:23:972659

DETAILS

STRATA PLAN LMS 3963

DETAIL SHOWING DEFLECTION ANGLES TYPICAL FOR SLs 287, 288, 292, 293, 297, AND 298.

Not To Scale

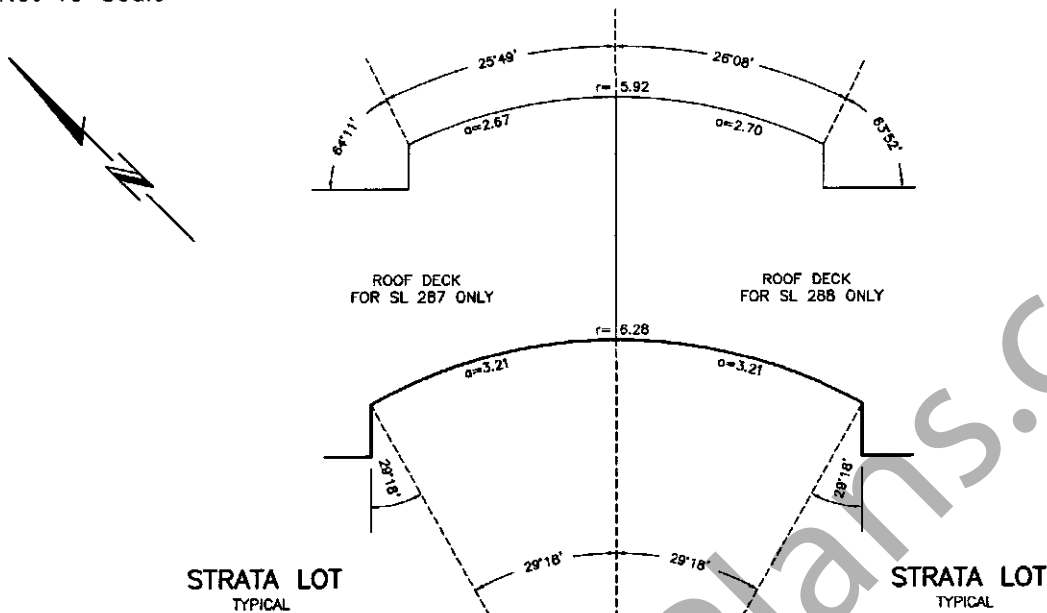

DETAIL SHOWING DEFLECTION ANGLES TYPICAL FOR SLs 285, 290 AND 295.

Not To Scale

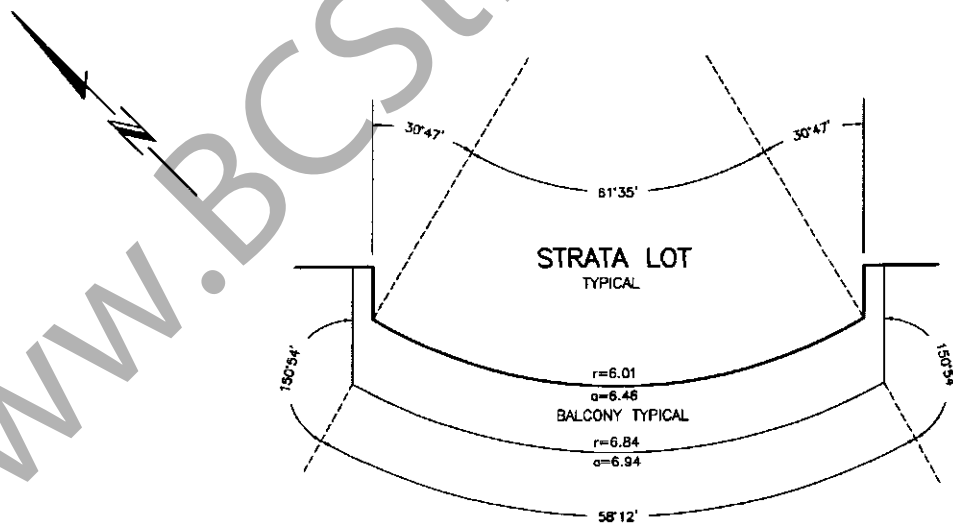

LEGEND

SL - DENOTES STRATA LOT  
FILE: C:\PK3\11963-3F.DWG

DATED THIS 24<sup>th</sup> DAY OF  
June, 1999.  
gub  
B.C.L.S.

FILED  
L\LMMS3963  
M47598 2007-01-18-16:38:23:972659

# LEVEL THREE FLOOR PLAN

Scale 1:250



ALL DISTANCES ARE IN METRES AND DECIMALS THEREOF.

# STRATA PLAN LMS 3963

ALL ANGLES ARE ASSUMED TO BE 90° UNLESS OTHERWISE SHOWN. FOR TYPICAL DEFLECTION ANGLES FOR SL 3 AND SL 8 SEE DETAIL ON SHEET 14.

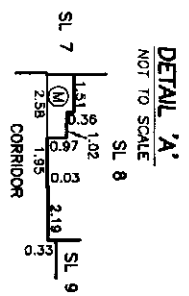
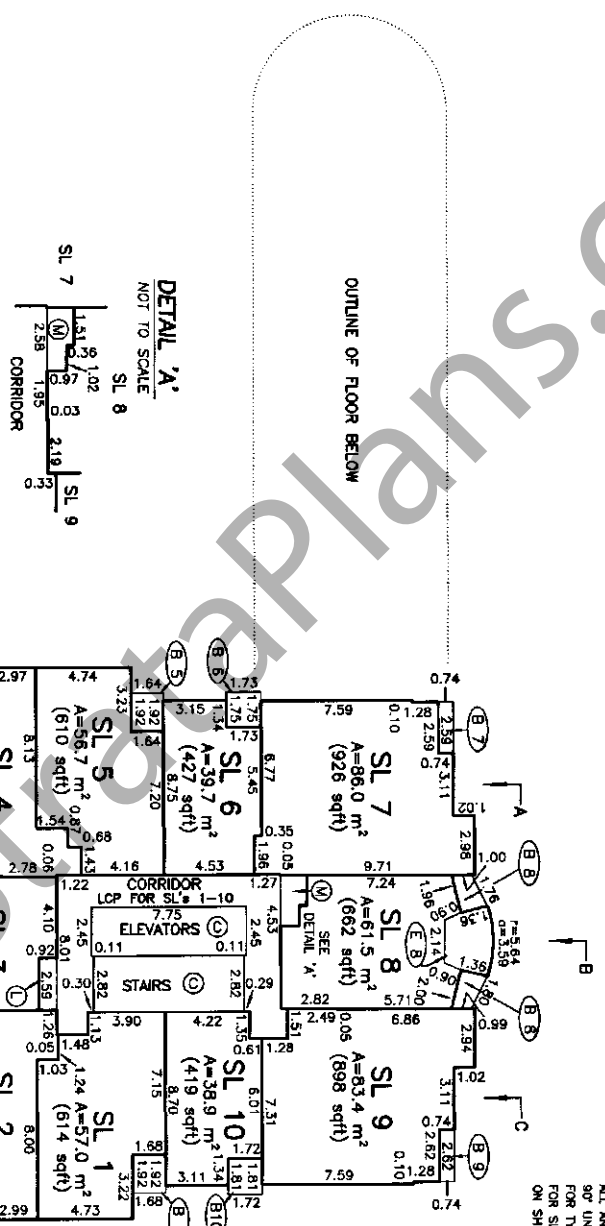

- LEGEND**
- A - DENOTES AREA
  - SL - DENOTES STRATA LOT
  - sqft - DENOTES SQUARE FEET
  - m<sup>2</sup> - DENOTES SQUARE METRES
  - ⊙ - COMMON PROPERTY
  - ⊙ - DENOTES MECHANICAL COMMON PROPERTY
  - ⊙ - DENOTES ELECTRICAL COMMON PROPERTY
  - LCP - DENOTES LIMITED COMMON PROPERTY
  - ⊙ - DENOTES BALCONY LCP FOR SL 12 (TYP.)
  - ⊙ - DENOTES ENCLOSED BALCONY PT SL 12 (TYP.)

FILE: C:\PK3\11963-2F.DWG

DATED THIS 24<sup>th</sup> DAY OF June, 1999.

*[Signature]*

B.C.L.S.



# FLOOR PLANS

# STRATA PLAN LMS 3963

Scale 1:250



ALL DISTANCES ARE IN METRES AND DECIMALS THEREOF.

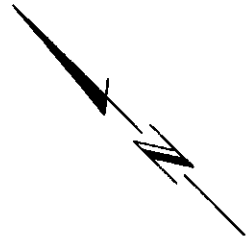

## LEVEL FOUR FLOOR PLAN

ALL ANGLES ARE ASSUMED TO BE 90° UNLESS OTHERWISE SHOWN. FOR TYPICAL DEFLECTION ANGLES FOR SL 13 AND SL 18 SEE DETAIL ON SHEET 14.

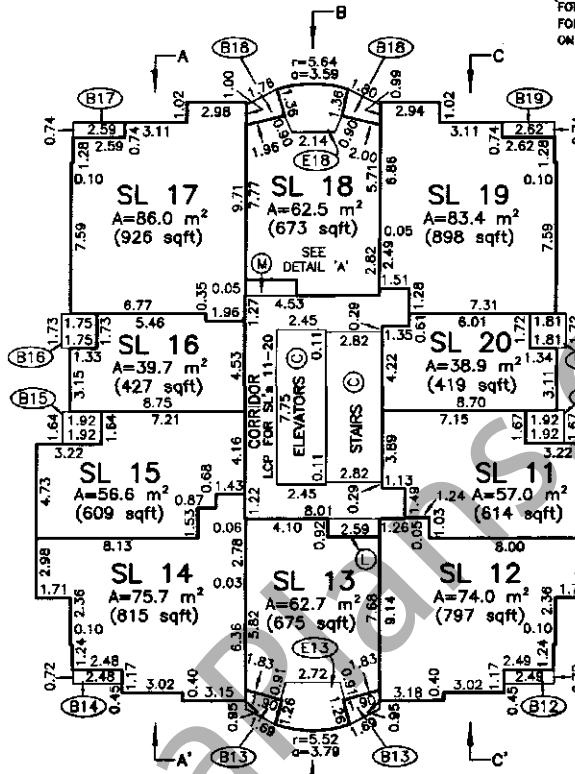

**DETAIL 'A'**  
NOT TO SCALE

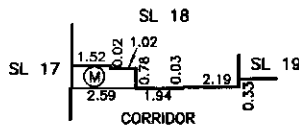

## LEVEL FIVE FLOOR PLAN

ALL ANGLES ARE ASSUMED TO BE 90° UNLESS OTHERWISE SHOWN. FOR TYPICAL DEFLECTION ANGLES FOR SL 23 AND SL 28 SEE DETAIL ON SHEET 14.

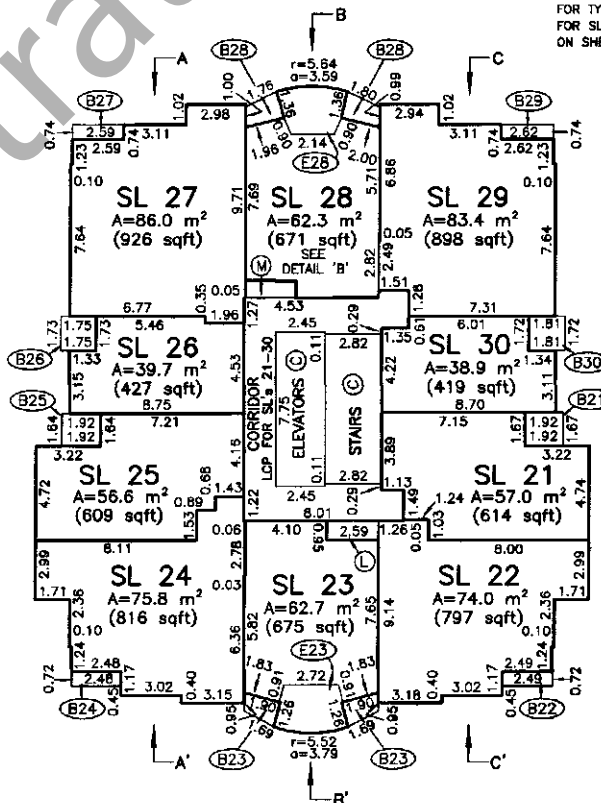

**DETAIL 'B'**  
NOT TO SCALE

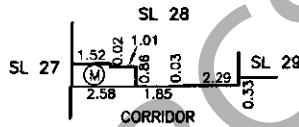

### LEGEND

- A — DENOTES AREA
- SL — DENOTES STRATA LOT
- sqft — DENOTES SQUARE FEET
- m<sup>2</sup> — DENOTES SQUARE METRES
- ⊙ — COMMON PROPERTY
- Ⓜ — DENOTES MECHANICAL COMMON PROPERTY
- Ⓛ — DENOTES ELECTRICAL COMMON PROPERTY
- LCP — DENOTES LIMITED COMMON PROPERTY
- Ⓟ12 — DENOTES BALCONY LCP FOR SL 12 (TYP.)
- Ⓛ12 — DENOTES ENCLOSED BALCONY PT SL 12 (TYP.)

FILE: C:\PK3\11963-3F.DWG

DATED THIS 24<sup>th</sup> DAY OF

June, 1999.

*gwb*

B.C.L.S.

# FLOOR PLANS

# STRATA PLAN LMS 3963

Scale 1:250



ALL DISTANCES ARE IN METRES AND DECIMALS THEREOF.

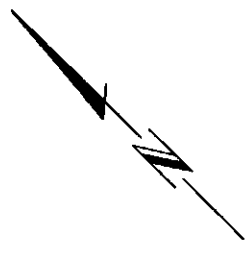

## LEVEL SIX FLOOR PLAN

ALL ANGLES ARE ASSUMED TO BE 90° UNLESS OTHERWISE SHOWN. FOR TYPICAL DEFLECTION ANGLES FOR SL 33 AND SL 38 SEE DETAIL ON SHEET 14.

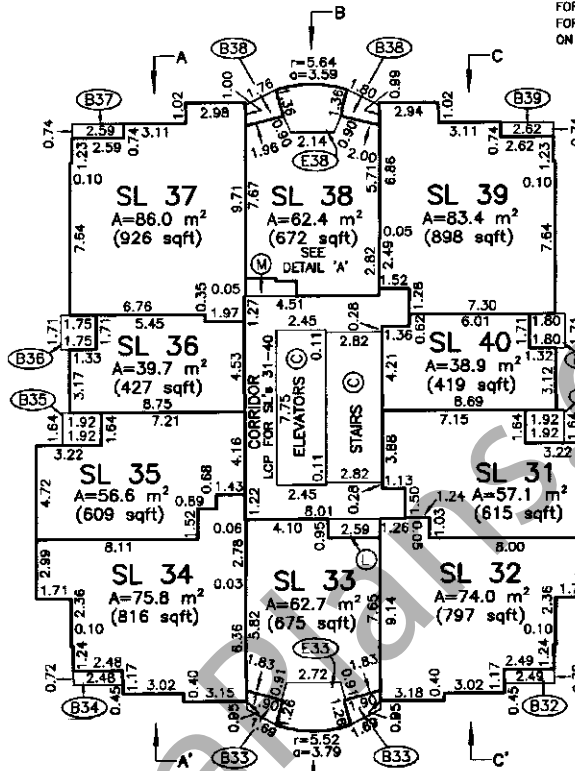

### DETAIL 'A'

NOT TO SCALE

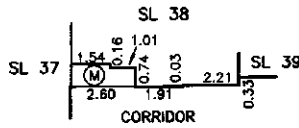

## LEVEL SEVEN FLOOR PLAN

ALL ANGLES ARE ASSUMED TO BE 90° UNLESS OTHERWISE SHOWN. FOR TYPICAL DEFLECTION ANGLES FOR SL 43 AND SL 48 SEE DETAIL ON SHEET 14.

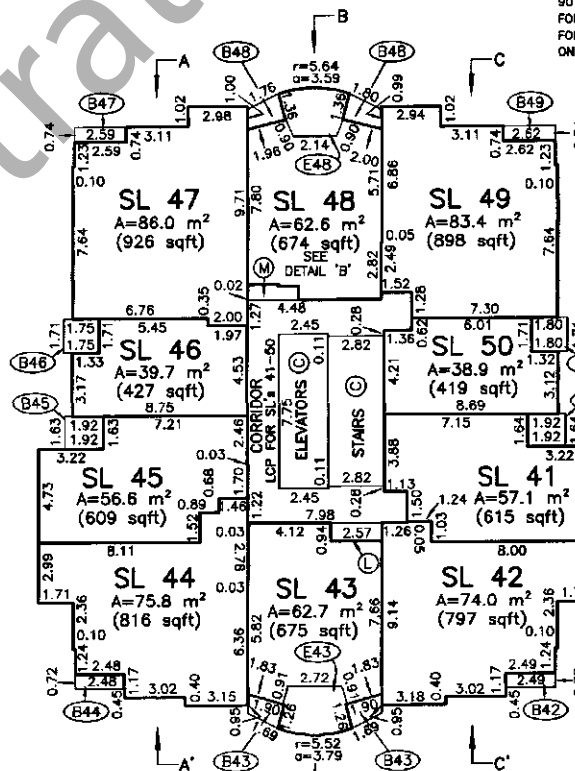

### DETAIL 'B'

NOT TO SCALE

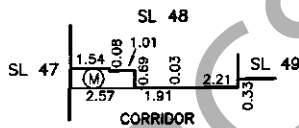

### LEGEND

- A - DENOTES AREA
- SL - DENOTES STRATA LOT
- sqft - DENOTES SQUARE FEET
- m<sup>2</sup> - DENOTES SQUARE METRES
- ⊙ - COMMON PROPERTY
- Ⓜ - DENOTES MECHANICAL COMMON PROPERTY
- Ⓛ - DENOTES ELECTRICAL COMMON PROPERTY
- LCP - DENOTES LIMITED COMMON PROPERTY
- Ⓢ12 - DENOTES BALCONY LCP FOR SL 12 (TYP.)
- Ⓢ12 - DENOTES ENCLOSED BALCONY PT SL 12 (TYP.)

DATED THIS 24<sup>th</sup> DAY OF

June, 1999. *gub*

FILED LMS3963 M47598 2007-01-18-16:38:23-972659

**FLOOR PLANS**

**STRATA PLAN LMS 3963**

Scale 1:250



ALL DISTANCES ARE IN METRES AND DECIMALS THEREOF.

**LEVEL EIGHT FLOOR PLAN**

ALL ANGLES ARE ASSUMED TO BE 90° UNLESS OTHERWISE SHOWN. FOR TYPICAL DEFLECTION ANGLES FOR SL 53 AND SL 58 SEE DETAIL ON SHEET 14.

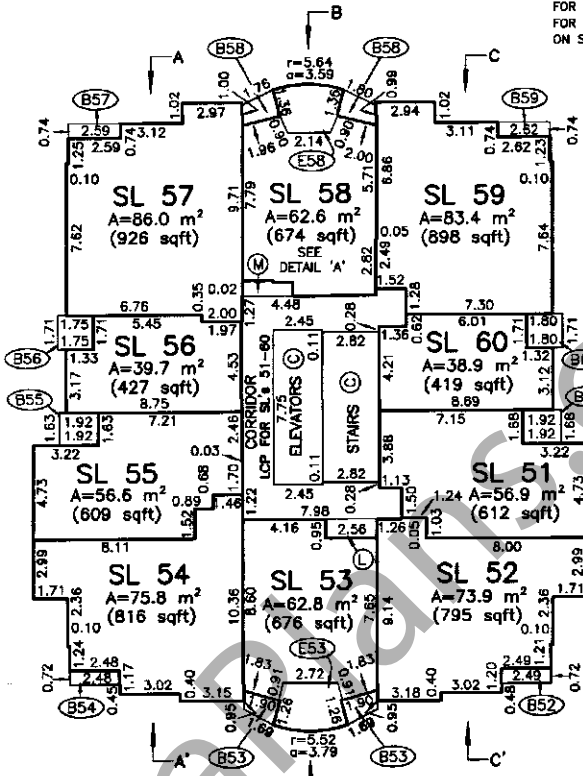
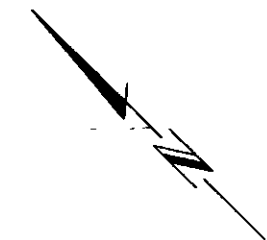

**DETAIL 'A'**  
NOT TO SCALE

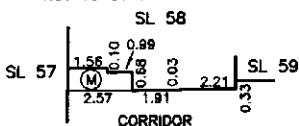

**LEVEL NINE FLOOR PLAN**

ALL ANGLES ARE ASSUMED TO BE 90° UNLESS OTHERWISE SHOWN. FOR TYPICAL DEFLECTION ANGLES FOR SL 63 AND SL 68 SEE DETAIL ON SHEET 14.

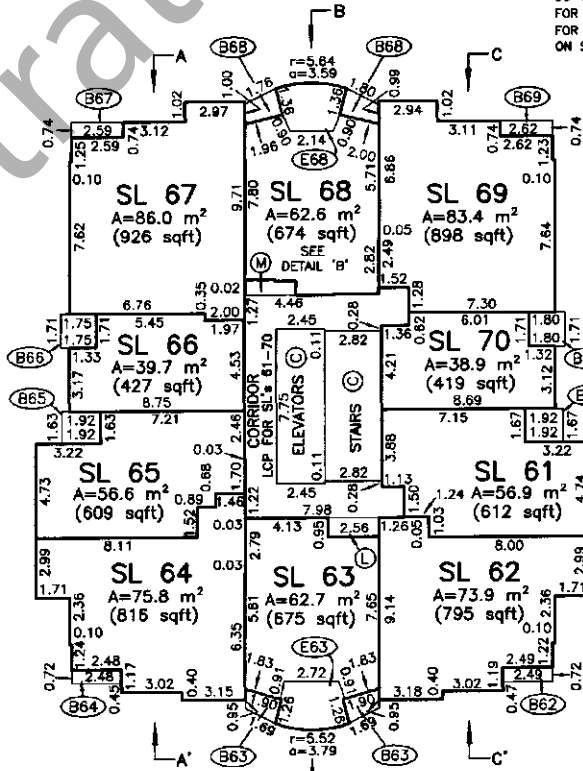
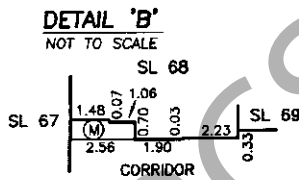

**LEGEND**

- A - DENOTES AREA
- SL - DENOTES STRATA LOT
- sqft - DENOTES SQUARE FEET
- m<sup>2</sup> - DENOTES SQUARE METRES
- ⊙ - COMMON PROPERTY
- Ⓜ - DENOTES MECHANICAL COMMON PROPERTY
- Ⓛ - DENOTES ELECTRICAL COMMON PROPERTY
- LCP - DENOTES LIMITED COMMON PROPERTY
- Ⓛ12 - DENOTES BALCONY LCP FOR SL 12 (TYP.)
- Ⓛ12 - DENOTES ENCLOSED BALCONY PT SL 12 (TYP.)

DATED THIS 24<sup>th</sup> DAY OF June, 1999.  
*gub*

FILED LMS3963 M47598 2007-01-18-16:38:23-972659

# FLOOR PLANS

# STRATA PLAN LMS 3963

Scale 1:250

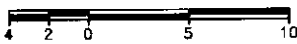

ALL DISTANCES ARE IN METRES AND DECIMALS THEREOF.

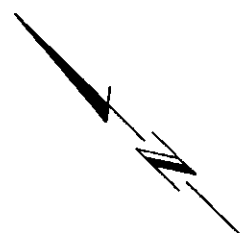

## LEVEL TEN FLOOR PLAN

ALL ANGLES ARE ASSUMED TO BE 90° UNLESS OTHERWISE SHOWN. FOR TYPICAL DEFLECTION ANGLES FOR SL 73 AND SL 78 SEE DETAIL ON SHEET 14.

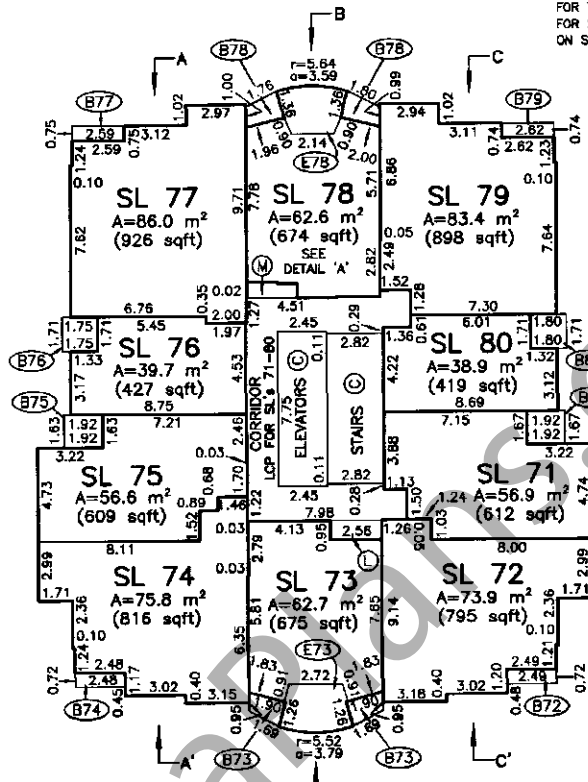

DETAIL 'A'  
NOT TO SCALE

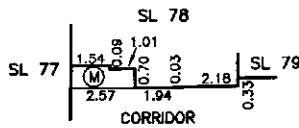

## LEVEL ELEVEN FLOOR PLAN

ALL ANGLES ARE ASSUMED TO BE 90° UNLESS OTHERWISE SHOWN. FOR TYPICAL DEFLECTION ANGLES FOR SL 83 AND SL 88 SEE DETAIL ON SHEET 14.

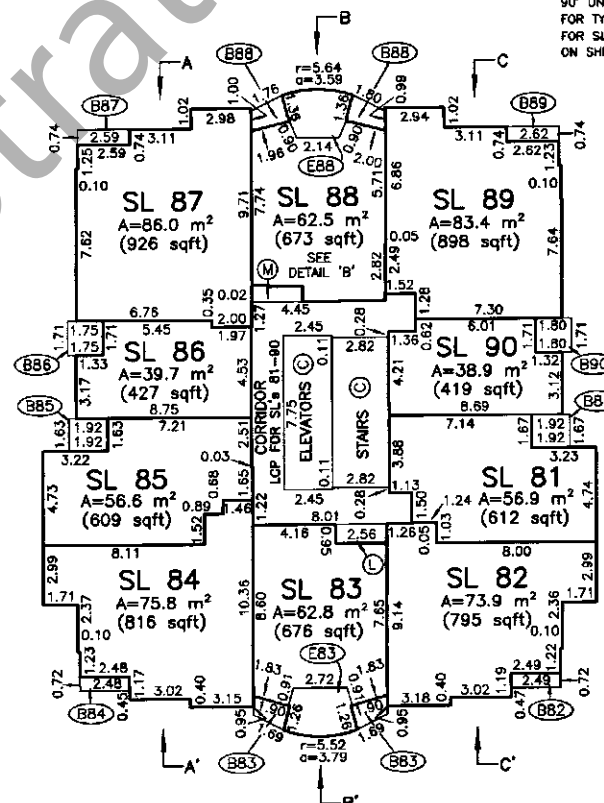

DETAIL 'B'  
NOT TO SCALE

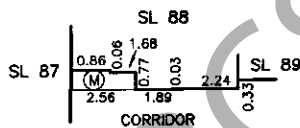

### LEGEND

- A - DENOTES AREA
- SL - DENOTES STRATA LOT
- sqft - DENOTES SQUARE FEET
- m<sup>2</sup> - DENOTES SQUARE METRES
- (C) - COMMON PROPERTY
- (M) - DENOTES MECHANICAL COMMON PROPERTY
- (L) - DENOTES ELECTRICAL COMMON PROPERTY
- LCP - DENOTES LIMITED COMMON PROPERTY
- (B12) - DENOTES BALCONY LCP FOR SL 12 (TYP.)
- (E12) - DENOTES ENCLOSED BALCONY PT SL 12 (TYP.)

FILE: C:\PK3\11963-3F.DWG

DATED THIS 24<sup>th</sup> DAY OF

June, 1999

*gub*

B.C.L.S.

WWW.BCStrata.com

FILED LMS3963 M47598 2007-01-18-16:38:23.972659

# FLOOR PLANS

# STRATA PLAN LMS 3963

Scale 1:250

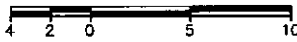

ALL DISTANCES ARE IN METRES AND DECIMALS THEREOF.

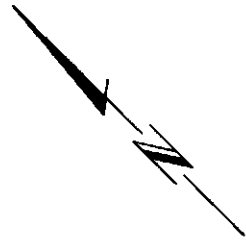

## LEVEL TWELVE FLOOR PLAN

ALL ANGLES ARE ASSUMED TO BE 90° UNLESS OTHERWISE SHOWN. FOR TYPICAL DEFLECTION ANGLES FOR SL 93 AND SL 98 SEE DETAIL ON SHEET 14.

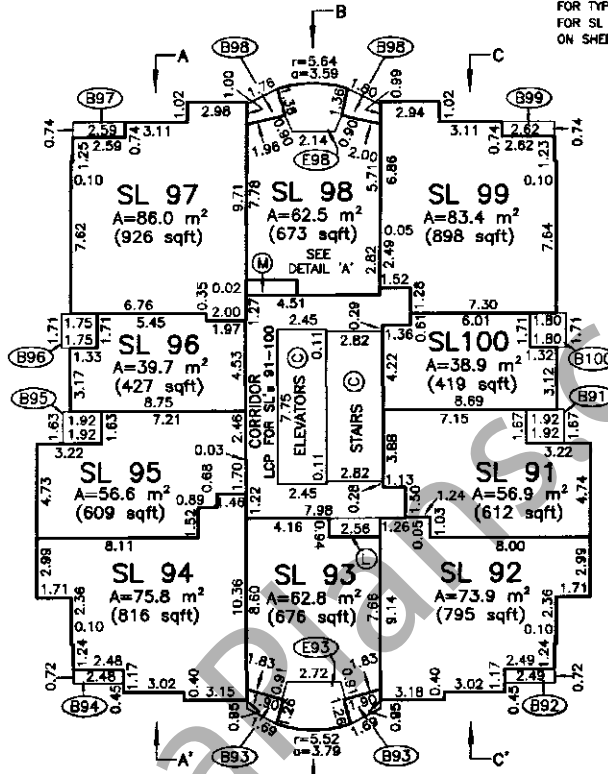

DETAIL 'A'  
NOT TO SCALE

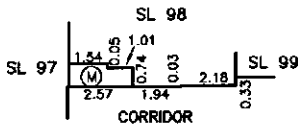

## LEVEL THIRTEEN FLOOR PLAN

ALL ANGLES ARE ASSUMED TO BE 90° UNLESS OTHERWISE SHOWN. FOR TYPICAL DEFLECTION ANGLES FOR SL 103 AND SL 108 SEE DETAIL ON SHEET 14.

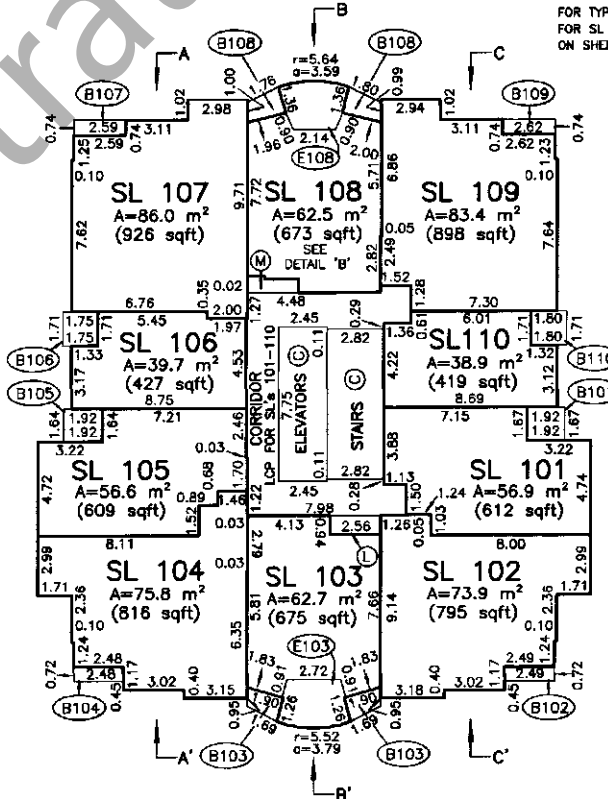

DETAIL 'B'  
NOT TO SCALE

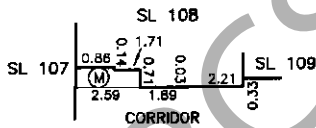

### LEGEND

- A - DENOTES AREA
- SL - DENOTES STRATA LOT
- sqft - DENOTES SQUARE FEET
- m<sup>2</sup> - DENOTES SQUARE METRES
- ⊙ - COMMON PROPERTY
- Ⓜ - DENOTES MECHANICAL COMMON PROPERTY
- Ⓛ - DENOTES ELECTRICAL COMMON PROPERTY
- LCP - DENOTES LIMITED COMMON PROPERTY
- Ⓛ12 - DENOTES BALCONY LCP FOR SL 12 (TYP.)
- Ⓛ12 - DENOTES ENCLOSED BALCONY PT SL 12 (TYP.)

FILE: C:\PK3\11963-3F.DWG

DATED THIS 24<sup>th</sup> DAY OF

June, 1999.

*gub*

B.C.L.S.

FILED L:\LMS\3963 M47598 2007-01-18-16:38:23:972659

**FLOOR PLANS**

**STRATA PLAN LMS 3963**

Scale 1:250

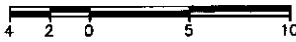

ALL DISTANCES ARE IN METRES AND DECIMALS THEREOF.

**LEVEL FOURTEEN FLOOR PLAN**

ALL ANGLES ARE ASSUMED TO BE 90° UNLESS OTHERWISE SHOWN. FOR TYPICAL DEFLECTION ANGLES FOR SL 113 AND SL 118 SEE DETAIL ON SHEET 14.

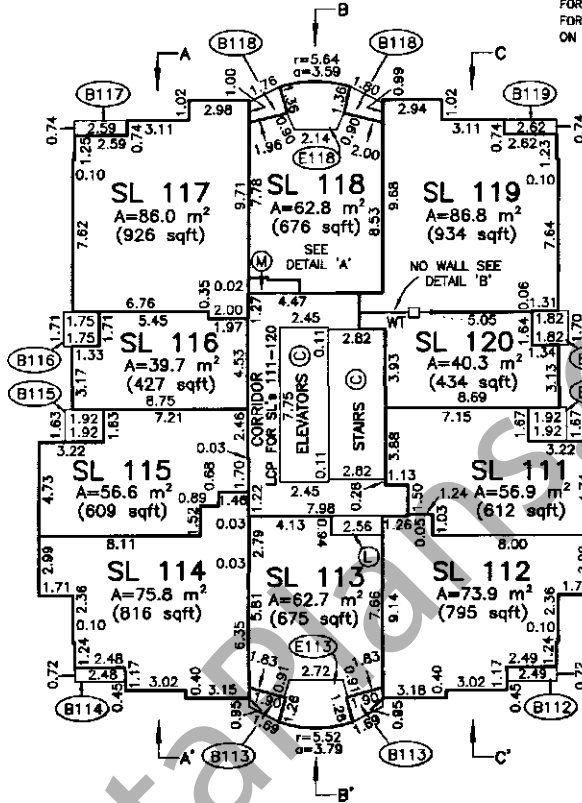
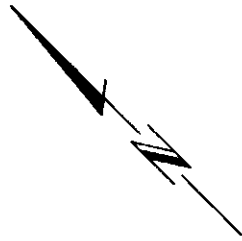

**DETAIL 'A'**  
NOT TO SCALE

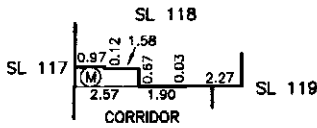

**DETAIL 'B'**  
NOT TO SCALE

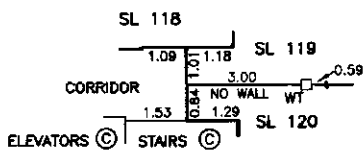

**LEVEL FIFTEEN FLOOR PLAN**

ALL ANGLES ARE ASSUMED TO BE 90° UNLESS OTHERWISE SHOWN. FOR TYPICAL DEFLECTION ANGLES FOR SL 123 AND SL 128 SEE DETAIL ON SHEET 14.

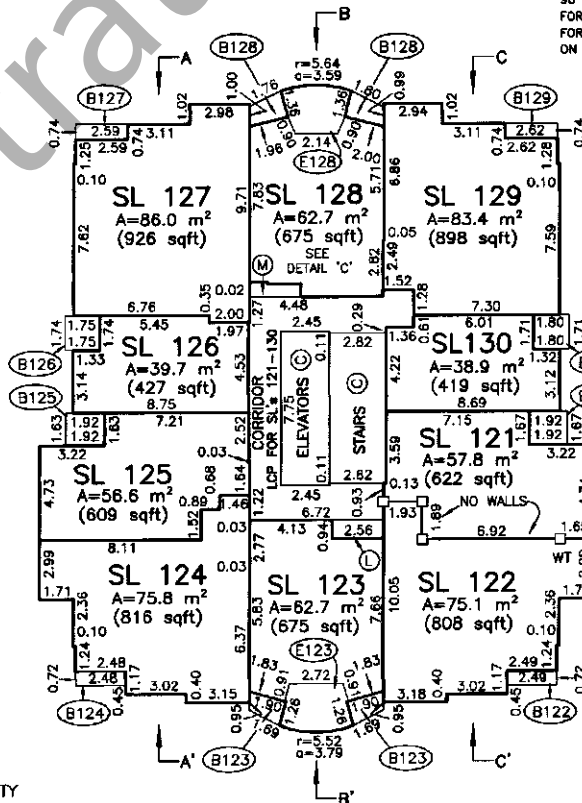

**DETAIL 'C'**  
NOT TO SCALE

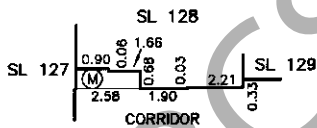

**LEGEND**

- A - DENOTES AREA
- WT - DENOTES WITNESS
- SL - DENOTES STRATA LOT
- sqft - DENOTES SQUARE FEET
- m<sup>2</sup> - DENOTES SQUARE METRES
- (C) - COMMON PROPERTY
- (M) - DENOTES MECHANICAL COMMON PROPERTY
- (L) - DENOTES ELECTRICAL COMMON PROPERTY
- LCP - DENOTES LIMITED COMMON PROPERTY
- - DENOTES LEAD PLUG SET
- (B12) - DENOTES BALCONY LCP FOR SL 12 (TYP.)
- (E12) - DENOTES ENCLOSED BALCONY PT SL 12 (TYP.)

FILE: C:\PK3\11963-3F.DWG

DATED THIS 24<sup>th</sup> DAY OF

June, 1999.

*gub*

B.C.L.S.

FLOOR PLANS

STRATA PLAN LMS 3963

Scale 1:250



ALL DISTANCES ARE IN METRES AND DECIMALS THEREOF.

LEVEL SIXTEEN FLOOR PLAN

ALL ANGLES ARE ASSUMED TO BE 90° UNLESS OTHERWISE SHOWN. FOR TYPICAL DEFLECTION ANGLES FOR SL 133 AND SL 136 SEE DETAIL ON SHEET 14.

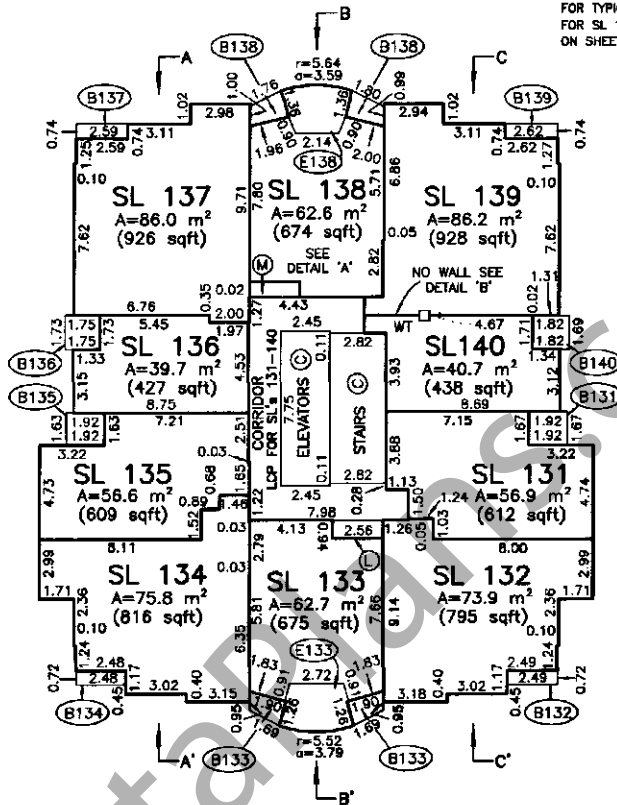
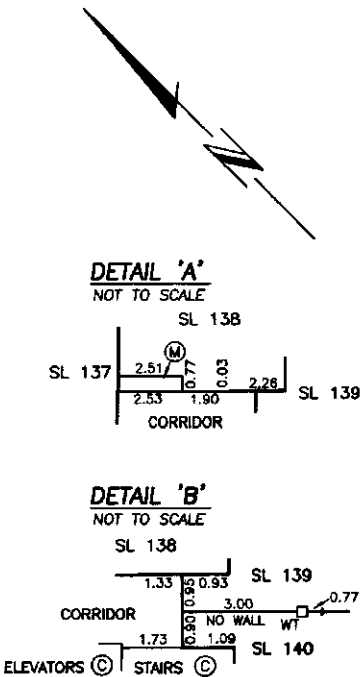

LEVEL SEVENTEEN FLOOR PLAN

ALL ANGLES ARE ASSUMED TO BE 90° UNLESS OTHERWISE SHOWN. FOR TYPICAL DEFLECTION ANGLES FOR SL 143 AND SL 148 SEE DETAIL ON SHEET 14.

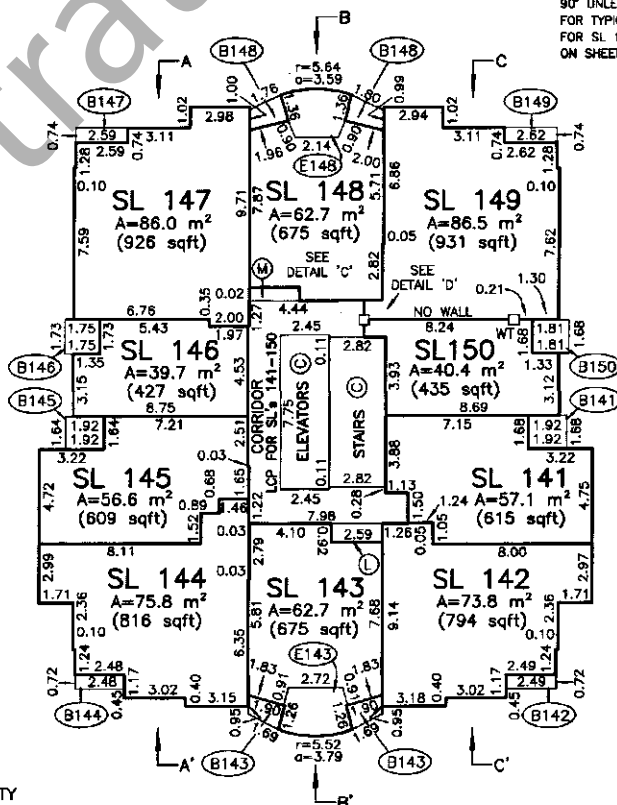
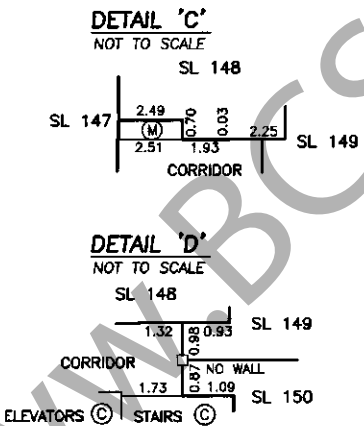

LEGEND

- A - DENOTES AREA
- WT - DENOTES WITNESS
- SL - DENOTES STRATA LOT
- sqft - DENOTES SQUARE FEET
- m<sup>2</sup> - DENOTES SQUARE METRES
- (C) - COMMON PROPERTY
- (M) - DENOTES MECHANICAL COMMON PROPERTY
- (E) - DENOTES ELECTRICAL COMMON PROPERTY
- LCP - DENOTES LIMITED COMMON PROPERTY
- - DENOTES LEAD PLUG SET
- (B12) - DENOTES BALCONY LCP FOR SL 12 (TYP.)
- (E12) - DENOTES ENCLOSED BALCONY PT SL 12 (TYP.)

FILE: C:\PK3\11963-3F.DWG

DATED THIS 24th DAY OF

June, 1999.

*[Signature]*

B.C.L.S.

# FLOOR PLANS

# STRATA PLAN LMS 3963

Scale 1:250



ALL DISTANCES ARE IN METRES AND DECIMALS THEREOF.

## LEVEL EIGHTEEN FLOOR PLAN

ALL ANGLES ARE ASSUMED TO BE 90° UNLESS OTHERWISE SHOWN. FOR TYPICAL DEFLECTION ANGLES FOR SL 153 AND SL 156 SEE DETAIL ON SHEET 14.

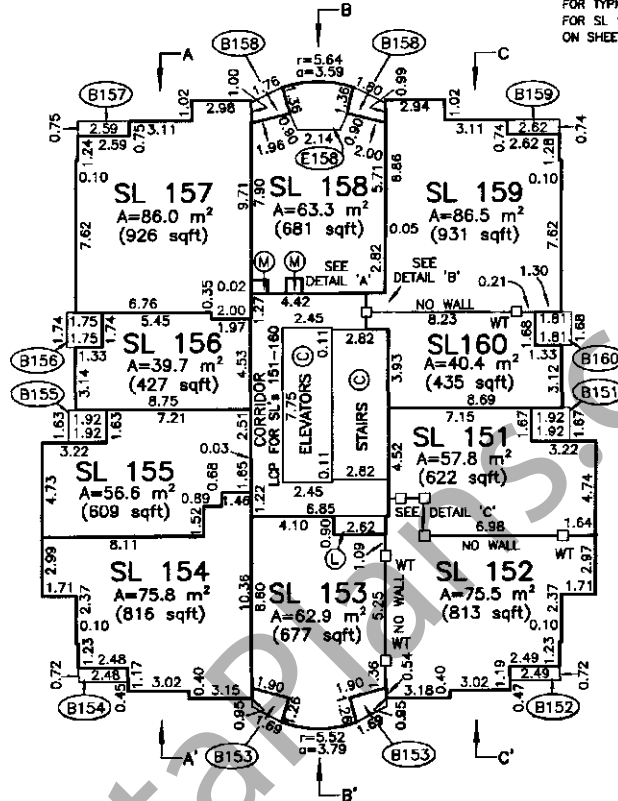
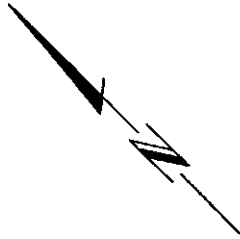

DETAIL 'A'  
NOT TO SCALE

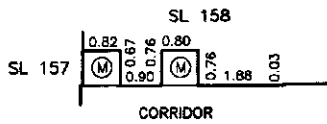

DETAIL 'B'  
NOT TO SCALE

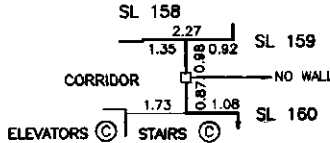

DETAIL 'C'  
NOT TO SCALE

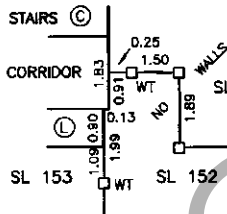

DETAIL 'D'  
NOT TO SCALE

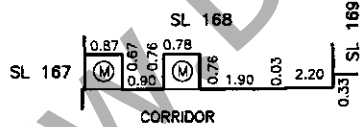

## LEVEL NINETEEN FLOOR PLAN

ALL ANGLES ARE ASSUMED TO BE 90° UNLESS OTHERWISE SHOWN. FOR TYPICAL DEFLECTION ANGLES FOR SL 163 AND SL 168 SEE DETAIL ON SHEET 14.

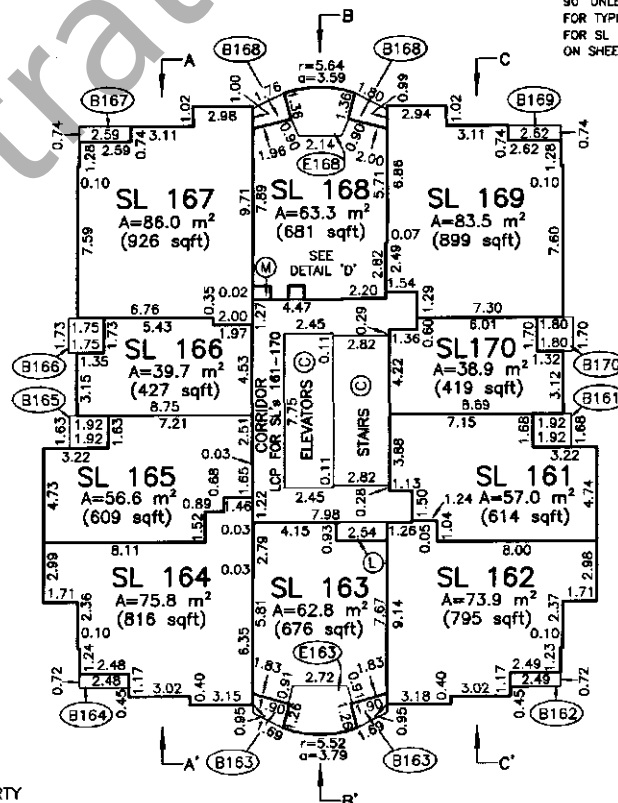

### LEGEND

- A - DENOTES AREA
- WT - DENOTES WITNESS
- SL - DENOTES STRATA LOT
- sqft - DENOTES SQUARE FEET
- m<sup>2</sup> - DENOTES SQUARE METRES
- (C) - COMMON PROPERTY
- (M) - DENOTES MECHANICAL COMMON PROPERTY
- (L) - DENOTES ELECTRICAL COMMON PROPERTY
- LCP - DENOTES LIMITED COMMON PROPERTY
- - DENOTES LEAD PLUG SET
- (B12) - DENOTES BALCONY LCP FOR SL 12 (TYP.)
- (E12) - DENOTES ENCLOSED BALCONY PT SL 12 (TYP.)

DATED THIS 24th DAY OF June, 1999.  
*[Signature]*



# FLOOR PLANS

# STRATA PLAN LMS 3963

Scale 1:250



ALL DISTANCES ARE IN METRES AND DECIMALS THEREOF.

## LEVEL TWENTY FLOOR PLAN

ALL ANGLES ARE ASSUMED TO BE 90° UNLESS OTHERWISE SHOWN. FOR TYPICAL DEFLECTION ANGLES FOR SL 173 AND SL 178 SEE DETAIL ON SHEET 14.

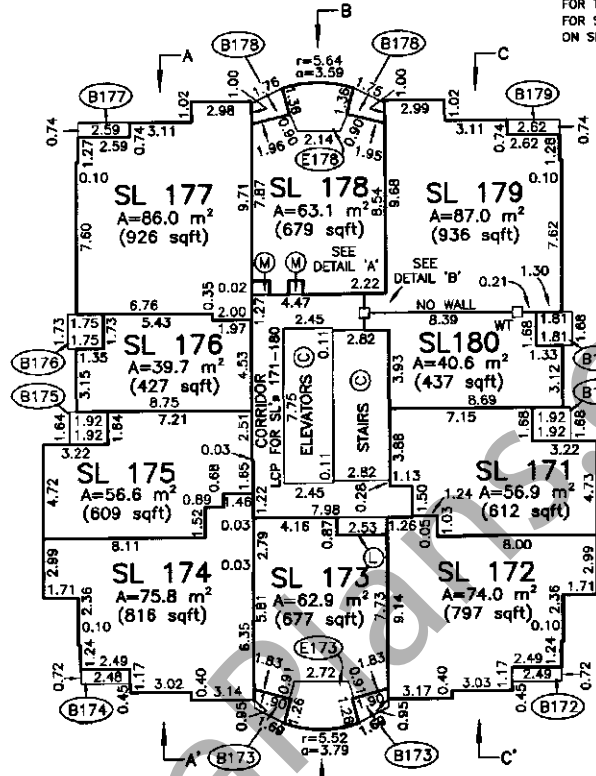
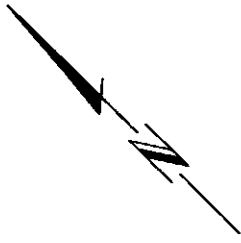

**DETAIL 'A'**  
NOT TO SCALE

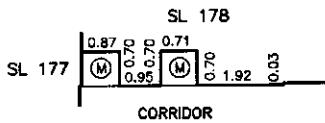

**DETAIL 'B'**  
NOT TO SCALE

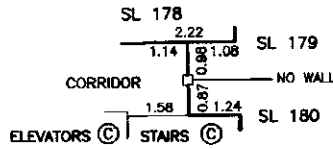

## LEVEL TWENTY-ONE FLOOR PLAN

ALL ANGLES ARE ASSUMED TO BE 90° UNLESS OTHERWISE SHOWN. FOR TYPICAL DEFLECTION ANGLES FOR SL 183 AND SL 188 SEE DETAIL ON SHEET 14.

**DETAIL 'C'**  
NOT TO SCALE

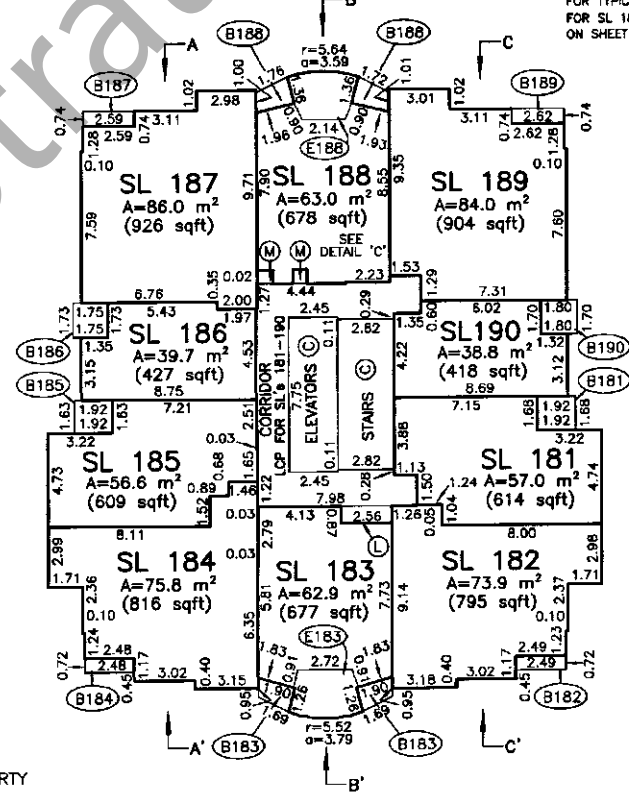
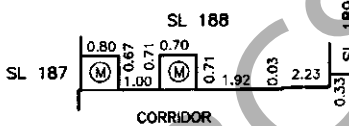

### LEGEND

- A - DENOTES AREA
- WT - DENOTES WITNESS
- SL - DENOTES STRATA LOT
- sqft - DENOTES SQUARE FEET
- m<sup>2</sup> - DENOTES SQUARE METRES
- ⊙ - COMMON PROPERTY
- ⊙(M) - DENOTES MECHANICAL COMMON PROPERTY
- ⊙(L) - DENOTES ELECTRICAL COMMON PROPERTY
- LCP - DENOTES LIMITED COMMON PROPERTY
- - DENOTES LEAD PLUG SET
- ⊙(B12) - DENOTES BALCONY LCP FOR SL 12 (TYP.)
- ⊙(E12) - DENOTES ENCLOSED BALCONY PT SL 12 (TYP.)

DATED THIS 24th DAY OF

June, 1999.

*gub*

B.C.L.S.

# FLOOR PLANS

# STRATA PLAN LMS 3963

Scale 1:250

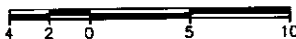

ALL DISTANCES ARE IN METRES AND DECIMALS THEREOF.

## LEVEL TWENTY-TWO FLOOR PLAN

ALL ANGLES ARE ASSUMED TO BE 90° UNLESS OTHERWISE SHOWN. FOR TYPICAL DEFLECTION ANGLES FOR SL 193 AND SL 198 SEE DETAIL ON SHEET 14.

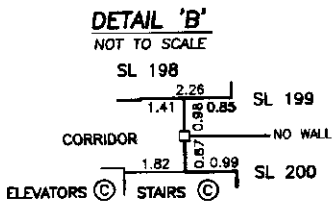
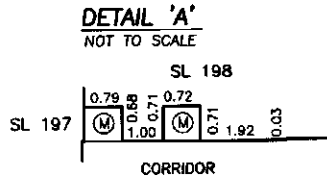
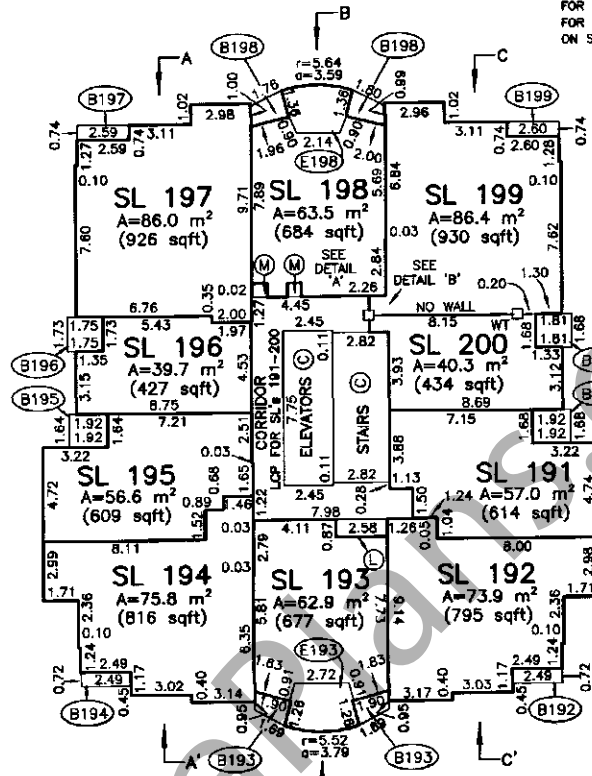
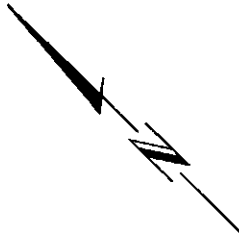

## LEVEL TWENTY-THREE FLOOR PLAN

ALL ANGLES ARE ASSUMED TO BE 90° UNLESS OTHERWISE SHOWN. FOR TYPICAL DEFLECTION ANGLES FOR SL 203 AND SL 208 SEE DETAIL ON SHEET 14.

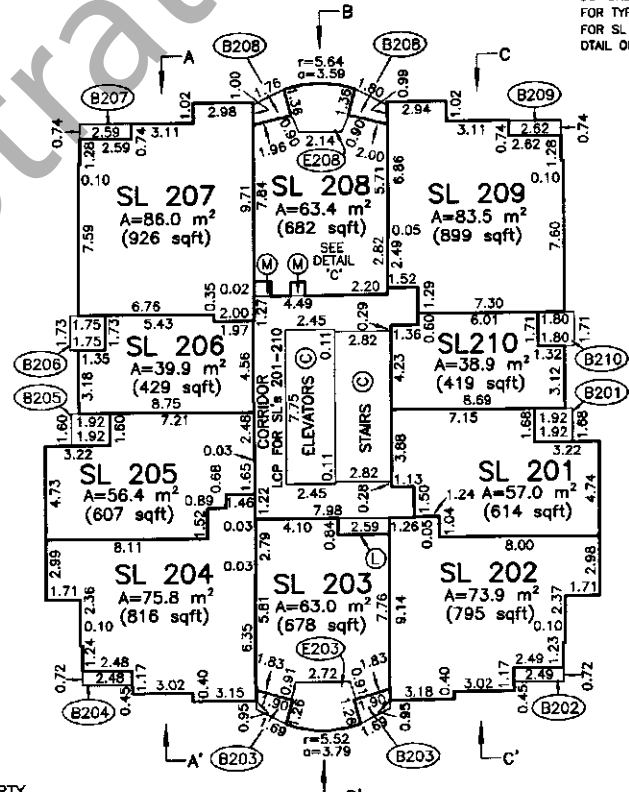
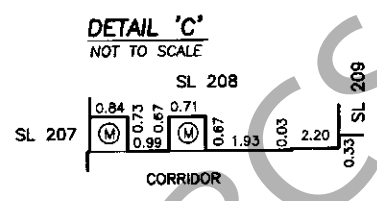

### LEGEND

- A — DENOTES AREA
- WT — DENOTES WITNESS
- SL — DENOTES STRATA LOT
- sqft — DENOTES SQUARE FEET
- m<sup>2</sup> — DENOTES SQUARE METRES
- ⊙ — COMMON PROPERTY
- Ⓜ — DENOTES MECHANICAL COMMON PROPERTY
- Ⓛ — DENOTES ELECTRICAL COMMON PROPERTY
- LCP — DENOTES LIMITED COMMON PROPERTY
- — DENOTES LEAD PLUG SET
- Ⓟ — DENOTES BALCONY LCP FOR SL 12 (TYP.)
- Ⓜ — DENOTES ENCLOSED BALCONY PT SL 12 (TYP.)

DATED THIS 24<sup>th</sup> DAY OF June, 1999.

*[Signature]*

**FLOOR PLANS**

**STRATA PLAN LMS 3963**

SHEET 27 OF 39 SHEETS

Scale 1:250



ALL DISTANCES ARE IN METRES AND DECIMALS THEREOF.

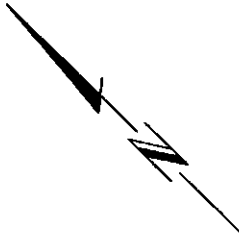

**LEVEL TWENTY-FOUR FLOOR PLAN**

ALL ANGLES ARE ASSUMED TO BE 90° UNLESS OTHERWISE SHOWN. FOR TYPICAL DEFLECTION ANGLES FOR SL 213 AND SL 218 SEE DETAIL ON SHEET 14.

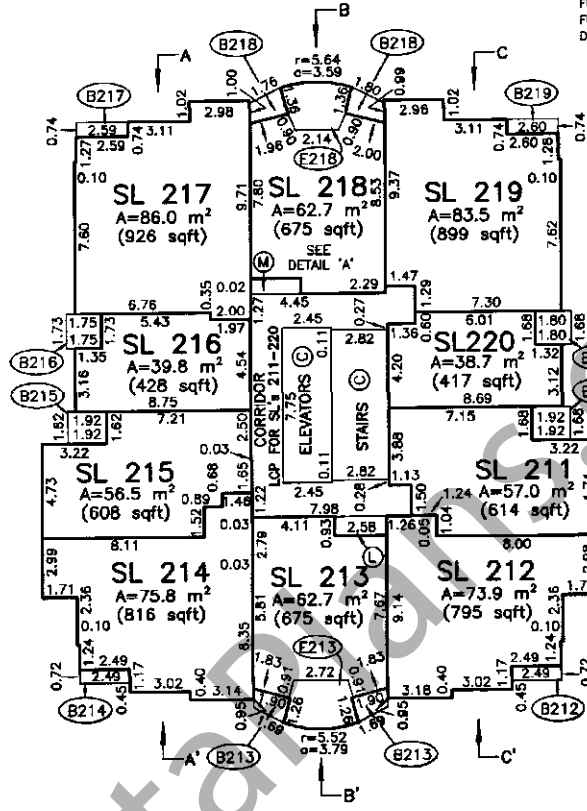
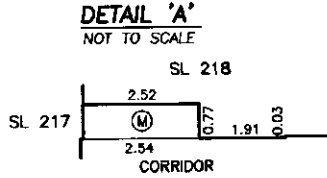

**LEVEL TWENTY-FIVE FLOOR PLAN**

ALL ANGLES ARE ASSUMED TO BE 90° UNLESS OTHERWISE SHOWN. FOR TYPICAL DEFLECTION ANGLES FOR SL 223, 227 AND SL 228 SEE DETAIL ON SHEET 14.

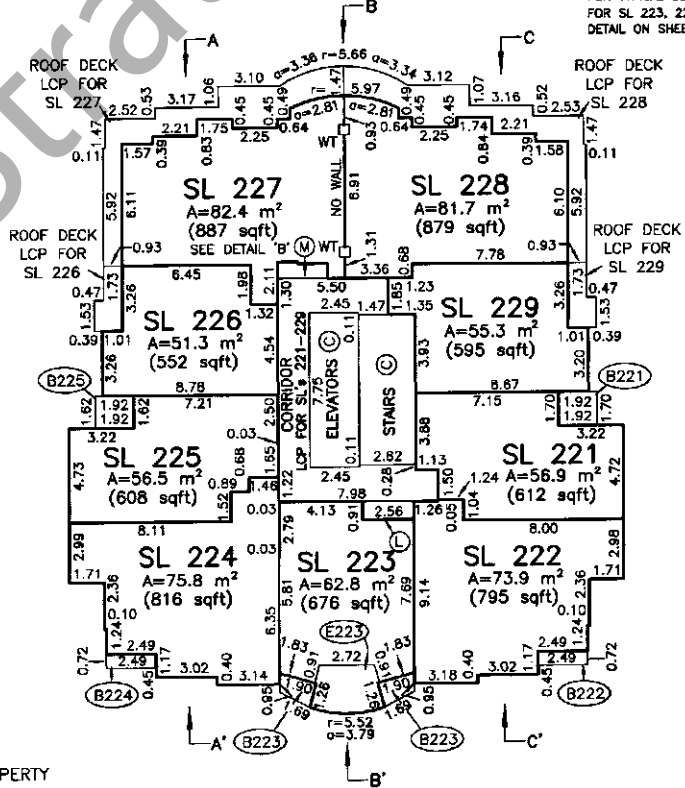
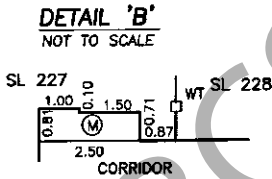

**LEGEND**

- A - DENOTES AREA
- WT - DENOTES WITNESS
- SL - DENOTES STRATA LOT
- sqft - DENOTES SQUARE FEET
- m<sup>2</sup> - DENOTES SQUARE METRES
- (C) - COMMON PROPERTY
- (M) - DENOTES MECHANICAL COMMON PROPERTY
- (E) - DENOTES ELECTRICAL COMMON PROPERTY
- LCP - DENOTES LIMITED COMMON PROPERTY
- - DENOTES LEAD PLUG SET
- (B12) - DENOTES BALCONY LCP FOR SL 12 (TYP.)
- (E12) - DENOTES ENCLOSED BALCONY PT SL 12 (TYP.)

FILE: C:\PK3\11963-4F.DWG

DATED THIS 24<sup>th</sup> DAY OF

June 1999

B.C.L.S.

FILED LMS3963 M47598 2007-01-18-16:38:23:972659

# FLOOR PLANS

# STRATA PLAN LMS 3963

Scale 1:250



ALL DISTANCES ARE IN METRES AND DECIMALS THEREOF.

## LEVEL TWENTY-SIX FLOOR PLAN

ALL ANGLES ARE ASSUMED TO BE 90° UNLESS OTHERWISE SHOWN. FOR TYPICAL DEFLECTION ANGLES FOR SL 232, 226 AND SL 237 SEE DETAIL ON SHEET 14.

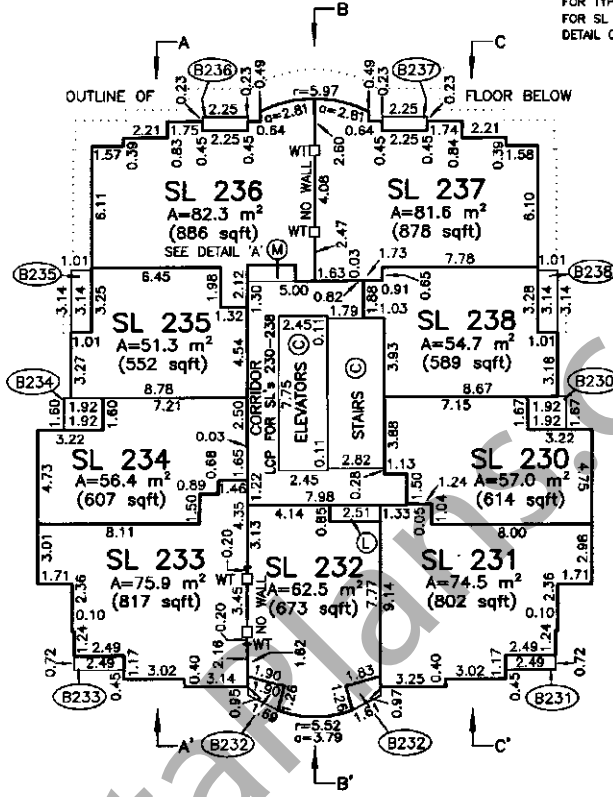
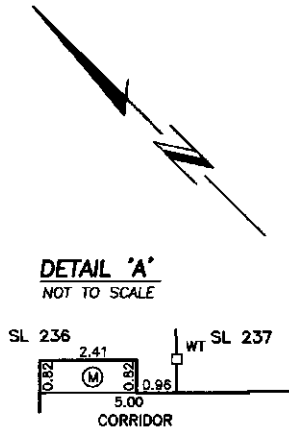

## LEVEL TWENTY-SEVEN FLOOR PLAN

ALL ANGLES ARE ASSUMED TO BE 90° UNLESS OTHERWISE SHOWN. FOR TYPICAL DEFLECTION ANGLES FOR SL 241, 245 AND SL 246 SEE DETAIL ON SHEET 14.

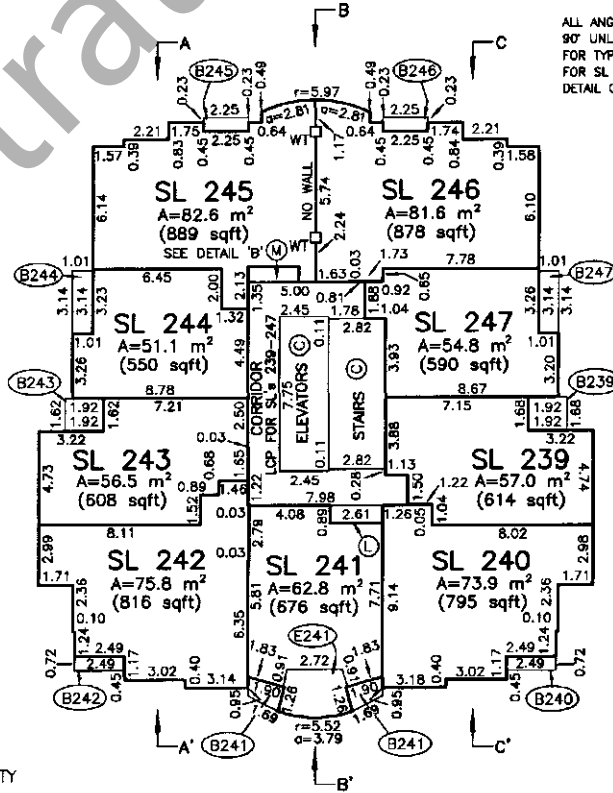
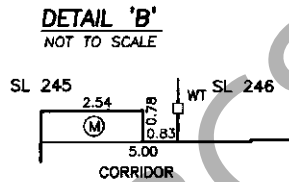

### LEGEND

- A - DENOTES AREA
- WT - DENOTES WITNESS
- SL - DENOTES STRATA LOT
- sqft - DENOTES SQUARE FEET
- m<sup>2</sup> - DENOTES SQUARE METRES
- ⊙ - DENOTES COMMON PROPERTY
- Ⓜ - DENOTES MECHANICAL COMMON PROPERTY
- Ⓛ - DENOTES ELECTRICAL COMMON PROPERTY
- LCP - DENOTES LIMITED COMMON PROPERTY
- - DENOTES LEAD PLUG SET
- Ⓟ12 - DENOTES BALCONY LCP FOR SL 12 (TYP.)
- Ⓛ12 - DENOTES ENCLOSED BALCONY PT SL 12 (TYP.)

DATED THIS 24<sup>th</sup> DAY OF

June, 1999

# FLOOR PLANS

# STRATA PLAN LMS 3963

Scale 1:250



ALL DISTANCES ARE IN METRES AND DECIMALS THEREOF.

## LEVEL TWENTY-EIGHT FLOOR PLAN

ALL ANGLES ARE ASSUMED TO BE 90° UNLESS OTHERWISE SHOWN. FOR TYPICAL DEFLECTION ANGLES FOR SL 250, 254 AND SL 255 SEE DETAIL ON SHEET 14.

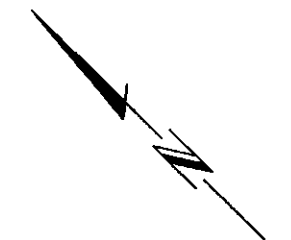

**DETAIL 'A'**  
NOT TO SCALE

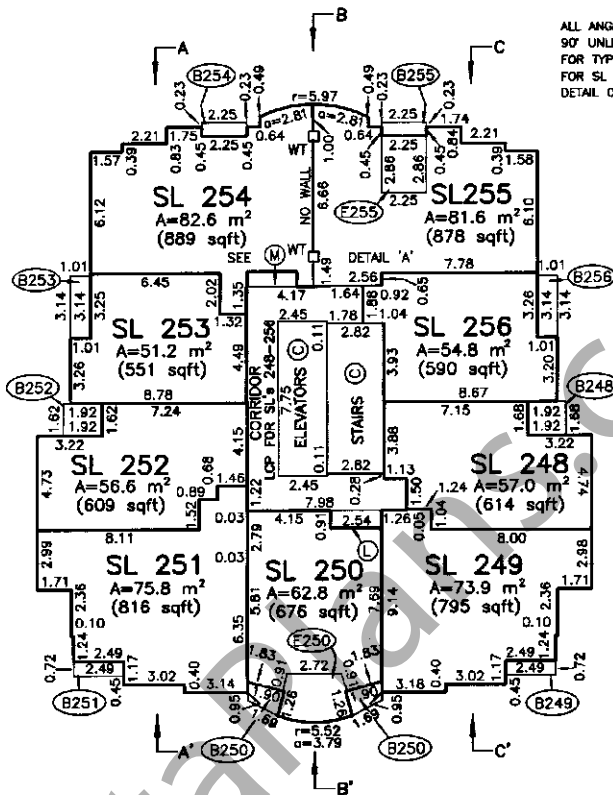
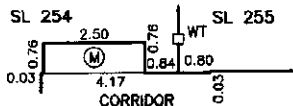

## LEVEL TWENTY-NINE FLOOR PLAN

ALL ANGLES ARE ASSUMED TO BE 90° UNLESS OTHERWISE SHOWN. FOR TYPICAL DEFLECTION ANGLES FOR SL 256, 263 AND SL 284 SEE DETAIL ON SHEET 14.

**DETAIL 'B'**  
NOT TO SCALE

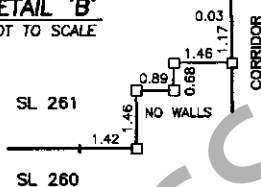

**DETAIL 'C'**  
NOT TO SCALE

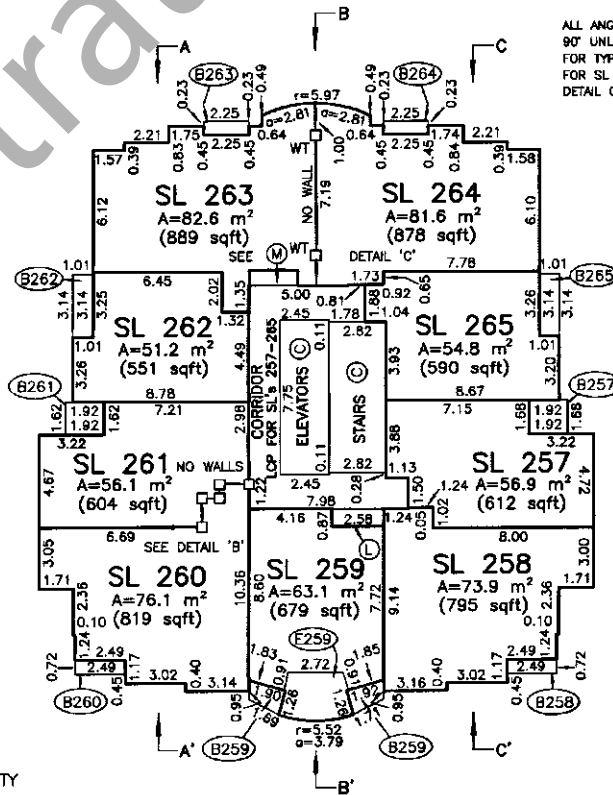
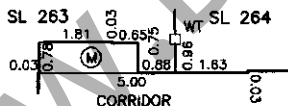

### LEGEND

- A - DENOTES AREA
- WT - DENOTES WITNESS
- SL - DENOTES STRATA LOT
- sqft - DENOTES SQUARE FEET
- m<sup>2</sup> - DENOTES SQUARE METRES
- (C) - COMMON PROPERTY
- (M) - DENOTES MECHANICAL COMMON PROPERTY
- (L) - DENOTES ELECTRICAL COMMON PROPERTY
- LCP - DENOTES LIMITED COMMON PROPERTY
- - DENOTES LEAD PLUG SET
- (B12) - DENOTES BALCONY LCP FOR SL 12 (TYP.)
- (E12) - DENOTES ENCLOSED BALCONY PT SL 12 (TYP.)

DATED THIS 24<sup>th</sup> DAY OF

June, 1999.

*gub*

# FLOOR PLANS

STRATA PLAN LMS 3963

Scale 1:250

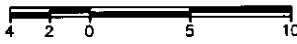

ALL DISTANCES ARE IN METRES AND DECIMALS THEREOF.

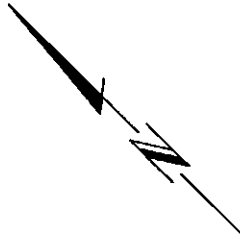

## LEVEL THIRTY FLOOR PLAN

ALL ANGLES ARE ASSUMED TO BE 90° UNLESS OTHERWISE SHOWN. FOR TYPICAL DEFLECTION ANGLES FOR SL 268, 272 AND SL 273 SEE DETAIL ON SHEET 14.

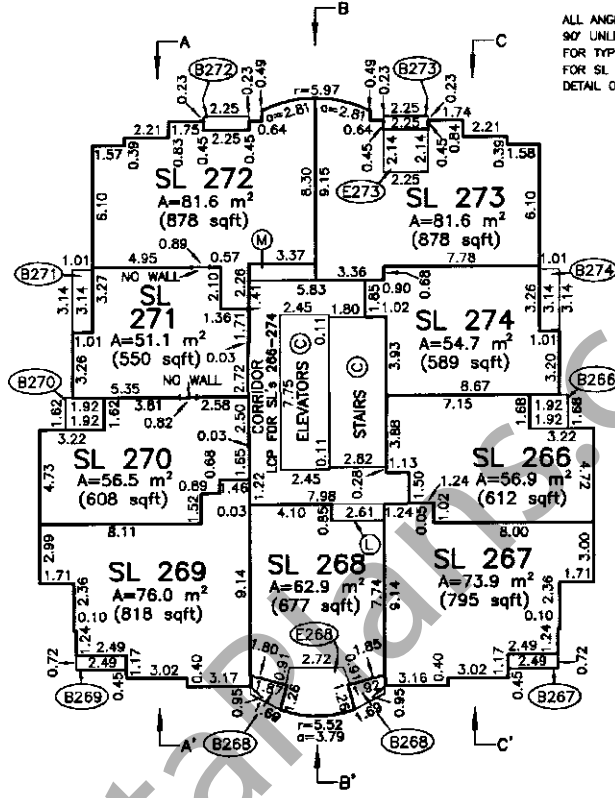

DETAIL 'A'  
NOT TO SCALE

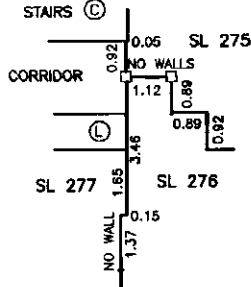

DETAIL 'B'  
NOT TO SCALE

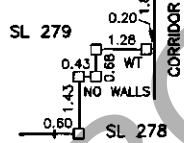

DETAIL 'C'  
NOT TO SCALE

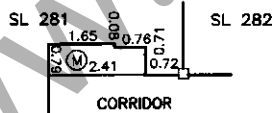

## LEVEL THIRTY-ONE FLOOR PLAN

ALL ANGLES ARE ASSUMED TO BE 90° UNLESS OTHERWISE SHOWN. FOR TYPICAL DEFLECTION ANGLES FOR SL 277, 281 AND SL 282 SEE DETAIL ON SHEET 14.

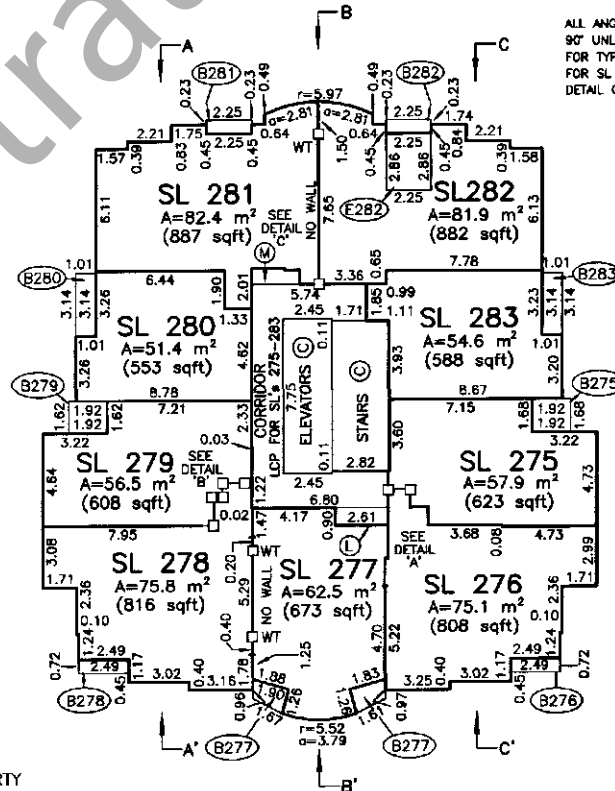

### LEGEND

- A - DENOTES AREA
- WT - DENOTES WITNESS
- SL - DENOTES STRATA LOT
- sqft - DENOTES SQUARE FEET
- m<sup>2</sup> - DENOTES SQUARE METRES
- ⊙ - COMMON PROPERTY
- Ⓜ - DENOTES MECHANICAL COMMON PROPERTY
- Ⓛ - DENOTES ELECTRICAL COMMON PROPERTY
- LCP - DENOTES LIMITED COMMON PROPERTY
- - DENOTES LEAD PLUG SET
- Ⓛ12 - DENOTES BALCONY LCP FOR SL 12 (TYP.)
- Ⓛ12 - DENOTES ENCLOSED BALCONY PT SL 12 (TYP.)

FILE: C:\PK3\11963-4F.DWG

DATED THIS 24<sup>th</sup> DAY OF

June, 1999.

*gub*

B.C.L.S.

FLOOR PLANS

STRATA PLAN LMS 3963

Scale 1:250



ALL DISTANCES ARE IN METRES AND DECIMALS THEREOF.

LEVEL THIRTY-FOUR FLOOR PLAN

ALL ANGLES ARE ASSUMED TO BE 90° UNLESS OTHERWISE SHOWN. FOR TYPICAL DEFLECTION ANGLES FOR SL 295, 297 AND SL 298 SEE DETAIL ON SHEET 15.

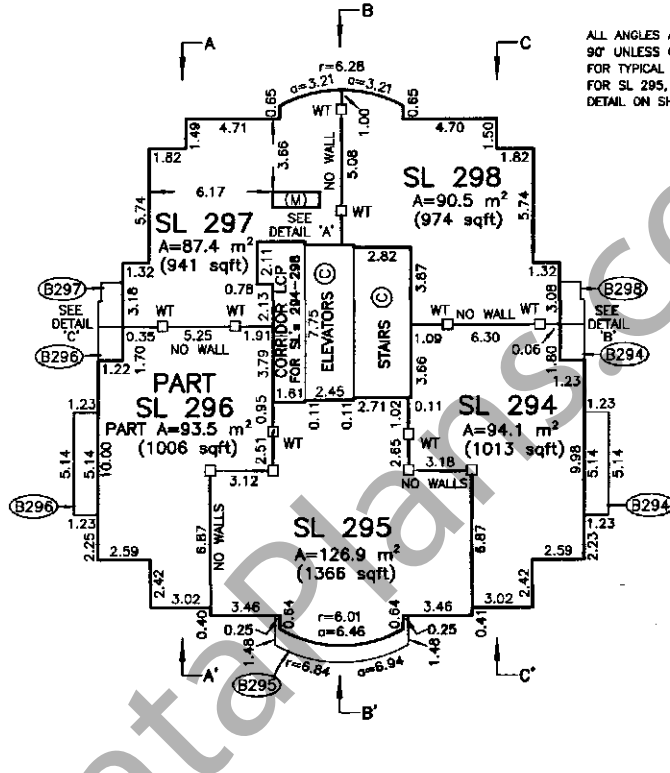

DETAIL 'A'  
NOT TO SCALE

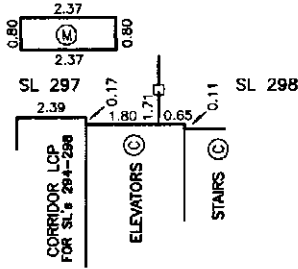

DETAIL 'B'  
NOT TO SCALE

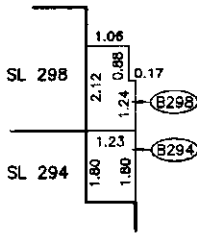

DETAIL 'C'  
NOT TO SCALE

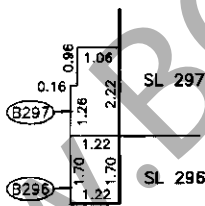

ROOF LEVEL FLOOR PLAN

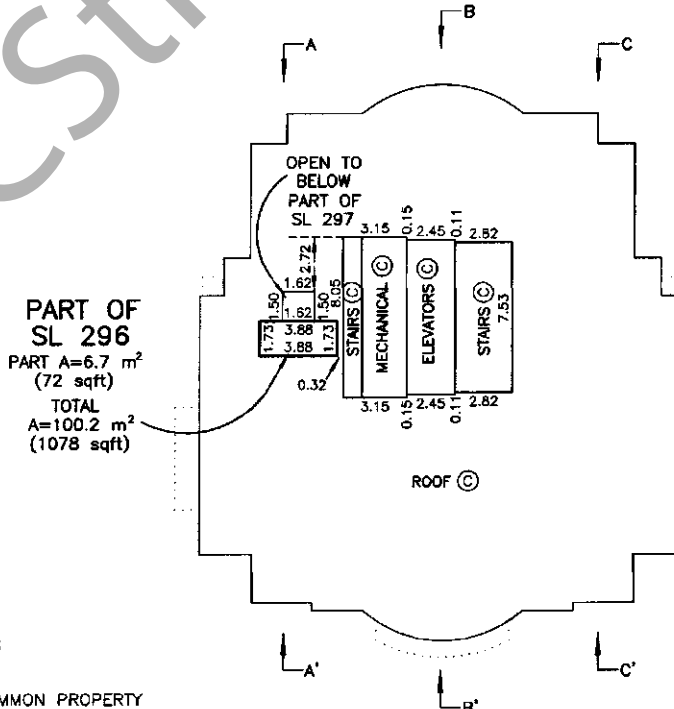

LEGEND

- A - DENOTES AREA
- WT - DENOTES WITNESS
- SL - DENOTES STRATA LOT
- sqft - DENOTES SQUARE FEET
- m<sup>2</sup> - DENOTES SQUARE METRES
- ⊙ - COMMON PROPERTY
- Ⓜ - DENOTES MECHANICAL COMMON PROPERTY
- Ⓛ - DENOTES ELECTRICAL COMMON PROPERTY
- LCP - DENOTES LIMITED COMMON PROPERTY
- - DENOTES LEAD PLUG SET
- Ⓛ12 - DENOTES BALCONY LCP FOR SL 12 (TYP.)
- Ⓛ12 - DENOTES ENCLOSED BALCONY PT SL 12 (TYP.)

DATED THIS 24<sup>th</sup> DAY OF

June, 1999.

*Jan B*

**FLOOR PLANS**

**STRATA PLAN LMS 3963**

Scale 1:250



ALL DISTANCES ARE IN METRES AND DECIMALS THEREOF.

**LEVEL THIRTY-TWO FLOOR PLAN**

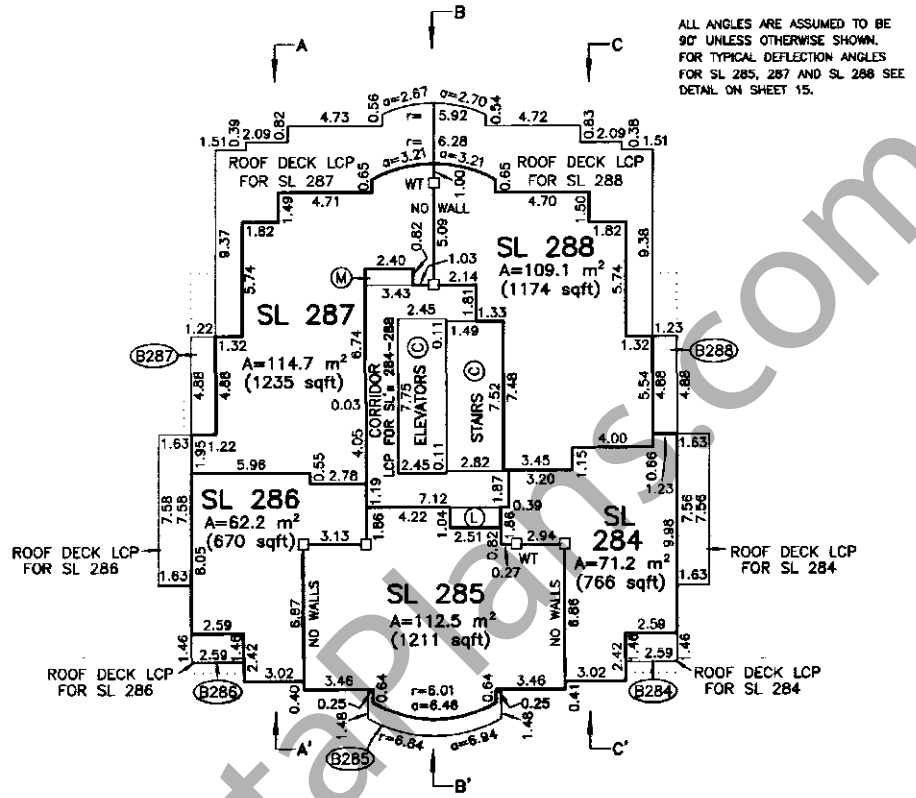

ALL ANGLES ARE ASSUMED TO BE 90° UNLESS OTHERWISE SHOWN. FOR TYPICAL DEFLECTION ANGLES FOR SL 285, 287 AND SL 288 SEE DETAIL ON SHEET 15.

**LEVEL THIRTY-THREE FLOOR PLAN**

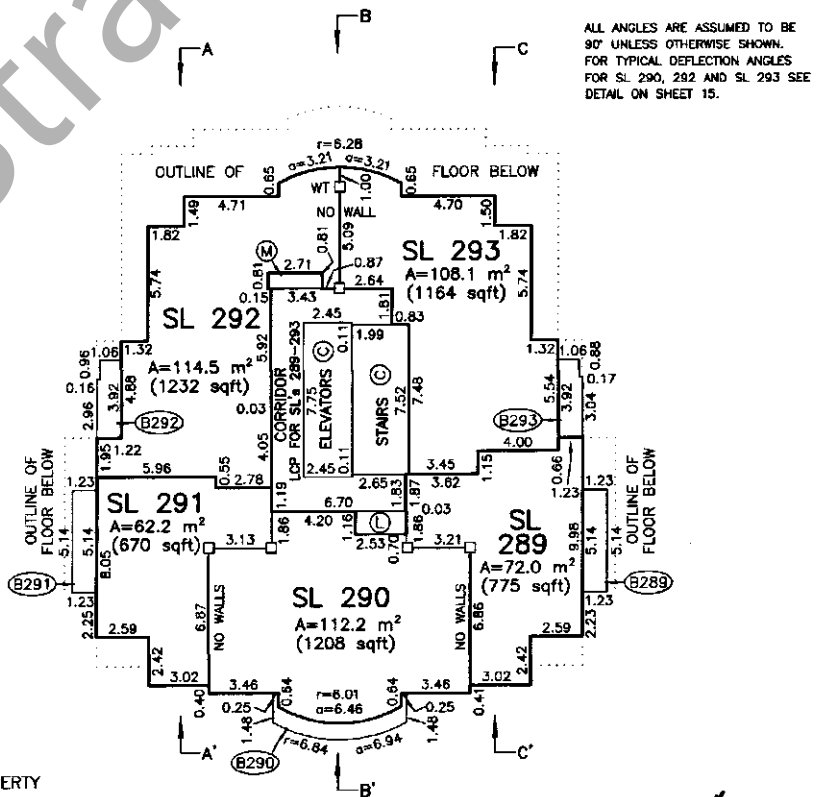

ALL ANGLES ARE ASSUMED TO BE 90° UNLESS OTHERWISE SHOWN. FOR TYPICAL DEFLECTION ANGLES FOR SL 290, 292 AND SL 293 SEE DETAIL ON SHEET 15.

**LEGEND**

- A — DENOTES AREA
- WT — DENOTES WITNESS
- SL — DENOTES STRATA LOT
- sqft — DENOTES SQUARE FEET
- m<sup>2</sup> — DENOTES SQUARE METRES
- ⊙ — COMMON PROPERTY
- Ⓜ — DENOTES MECHANICAL COMMON PROPERTY
- Ⓛ — DENOTES ELECTRICAL COMMON PROPERTY
- LCP — DENOTES LIMITED COMMON PROPERTY
- — DENOTES LEAD PLUG SET
- Ⓟ12 — DENOTES BALCONY LCP FOR SL 12 (TYP.)
- Ⓟ2 — DENOTES ENCLOSED BALCONY PT SL 12 (TYP.)

DATED THIS 24<sup>th</sup> DAY OF

June, 1999.

*[Signature]*



# ELEVATOR MACHINE ROOM FLOOR PLAN STRATA PLAN LMS 3963

Scale 1:250



ALL DISTANCES ARE IN METRES AND DECIMALS THEREOF.

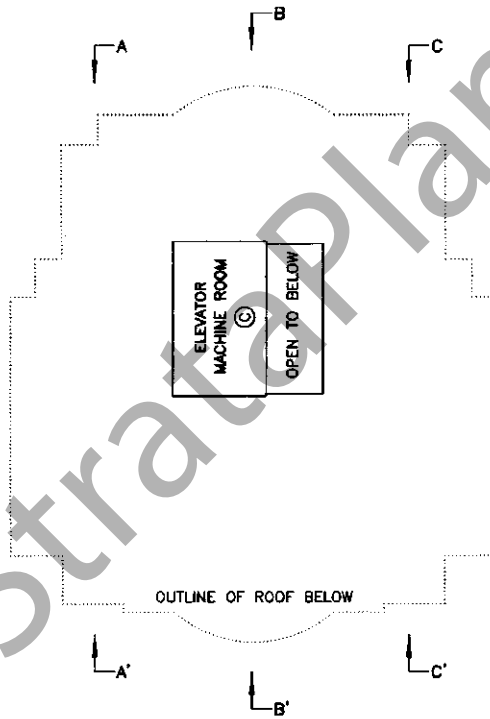
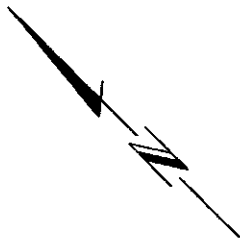

### LEGEND

© - COMMON PROPERTY

FILE: C:\PK3\11963-4F.DWG

DATED THIS 24<sup>th</sup> DAY OF June, 1999.

gwb

B.C.L.S.

www.BCStrataPlans.com

FILED  
LMS3963  
M47598 2007-01-18-16:38:23:972659

**SECTION A TO A'**

**STRATA PLAN LMS 3963**

Scale 1:250



ALL DISTANCES ARE IN METRES AND DECIMALS THEREOF.

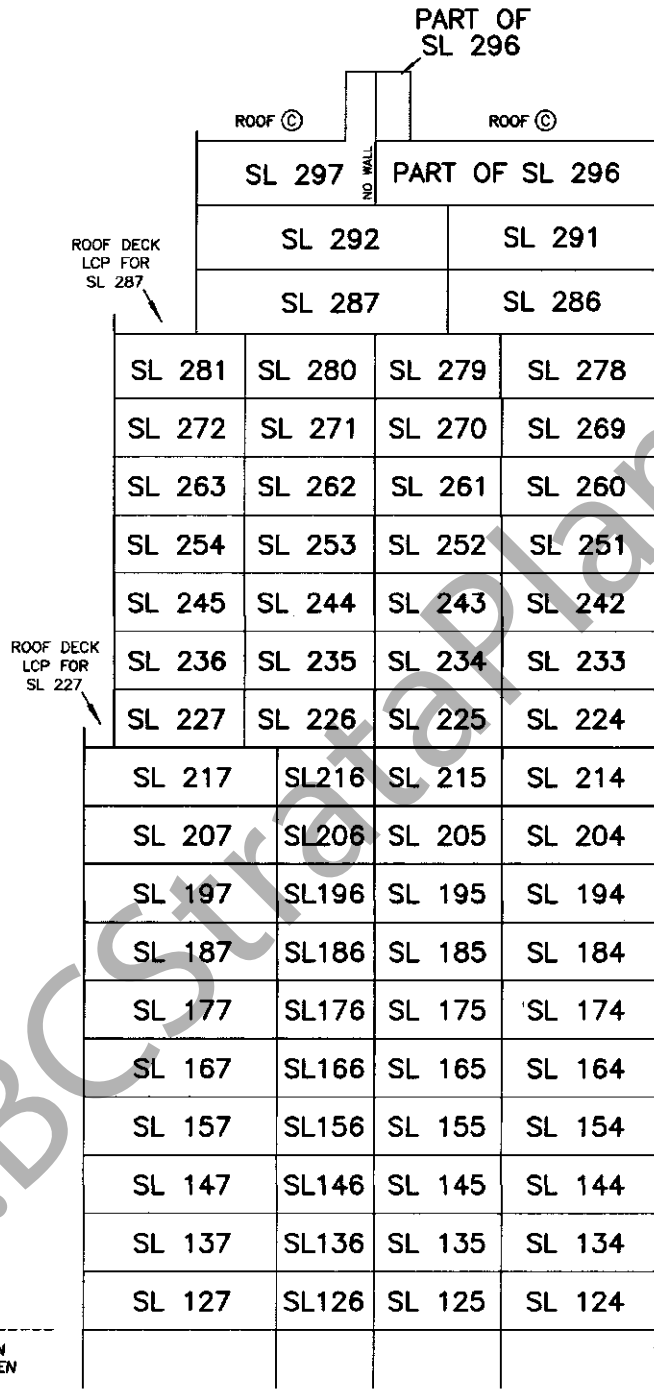

- ROOF LEVEL
- LEVEL THIRTY-FOUR
- LEVEL THIRTY-THREE
- LEVEL THIRTY-TWO
- LEVEL THIRTY-ONE
- LEVEL THIRTY
- LEVEL TWENTY-NINE
- LEVEL TWENTY-EIGHT
- LEVEL TWENTY-SEVEN
- LEVEL TWENTY-SIX
- LEVEL TWENTY-FIVE
- LEVEL TWENTY-FOUR
- LEVEL TWENTY-THREE
- LEVEL TWENTY-TWO
- LEVEL TWENTY-ONE
- LEVEL TWENTY
- LEVEL NINETEEN
- LEVEL EIGHTEEN
- LEVEL SEVENTEEN
- LEVEL SIXTEEN
- LEVEL FIFTEEN

CONTINUES DOWN TO LEVEL FOURTEEN (SEE SHEET 37)

**LEGEND**

SL - DENOTES STRATA LOT  
LCP - DENOTES LIMITED COMMON PROPERTY

FILE: C:\PK3\11963-4F.DWG

DATED THIS 24<sup>th</sup> DAY OF June, 1999.

B.C.L.S.

FILED LMS3963 M47598 2007-01-18-16:38:23-972659

SECTION B TO B'

STRATA PLAN LMS 3963

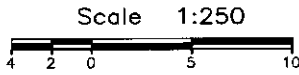

ALL DISTANCES ARE IN METRES AND DECIMALS THEREOF.

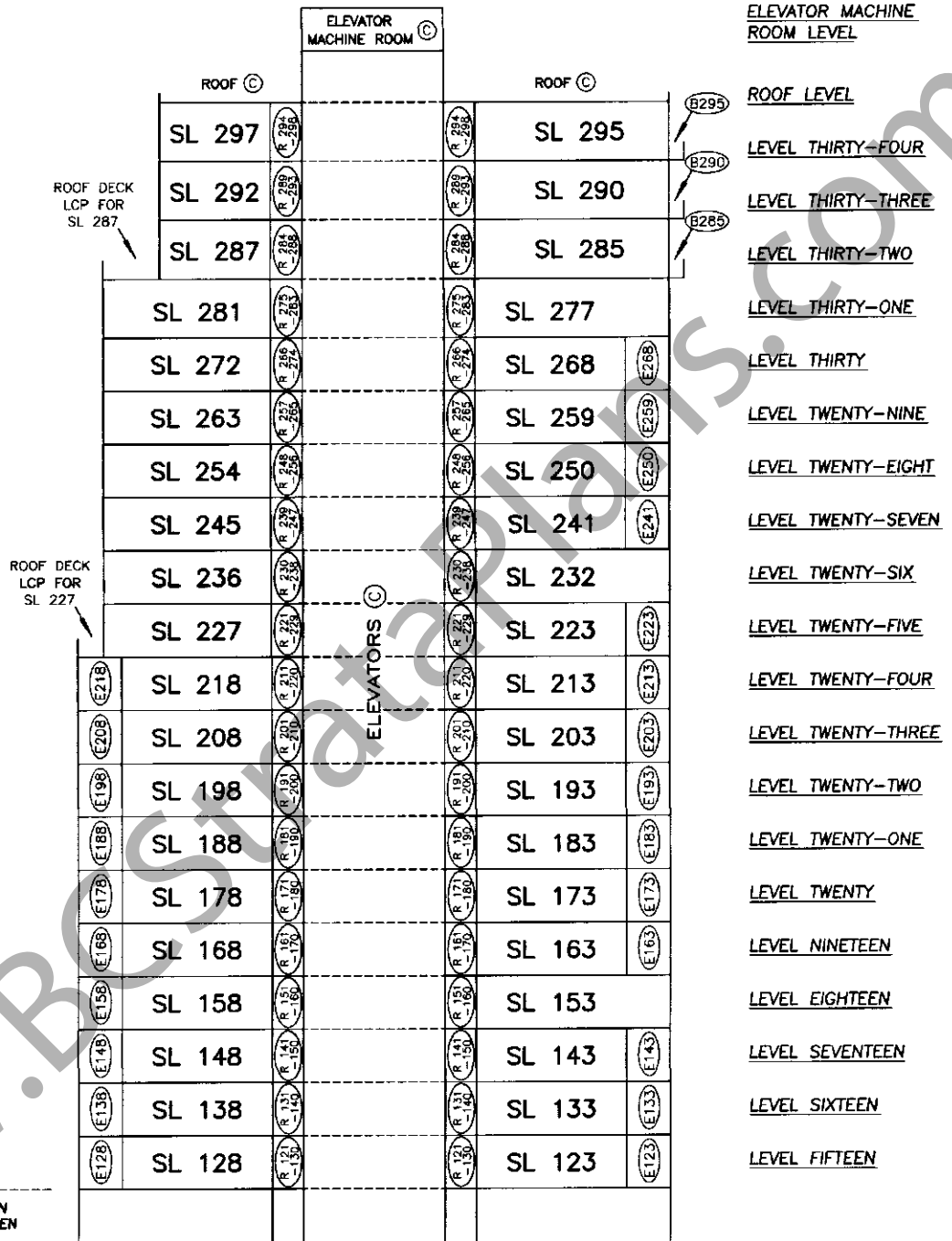

CONTINUES DOWN TO LEVEL FOURTEEN (SEE SHEET 38)

LEGEND

- SL - DENOTES STRATA LOT
- ⊙ - COMMON PROPERTY
- LCP - DENOTES LIMITED COMMON PROPERTY
- (R 121/130) - DENOTES CORRIDOR LCP FOR SL'S 121 TO 130 (TYP.)
- (E12) - DENOTES ENCLOSED BALCONY PT SL 12 (TYP.)
- (B12) - DENOTES BALCONY LCP FOR SL 12 (TYP.)

DATED THIS 24<sup>th</sup> DAY OF

June, 1999  
*[Signature]*

**SECTION C TO C'**

**STRATA PLAN LMS 3963**

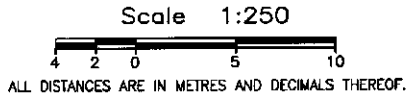

ROOF ©			
SL 298		NO WALL	SL 294
SL 293			SL 289
SL 288			SL 284
SL 282	SL 283	SL 275	SL 276
SL 273	SL 274	SL 266	SL 267
SL 264	SL 265	SL 257	SL 258
SL 255	SL 256	SL 248	SL 249
SL 246	SL 247	SL 239	SL 240
SL 237	SL 238	SL 230	SL 231
SL 228	SL 229	SL 221	SL 222
SL 219	SL 220	SL 211	SL 212
SL 209	SL 210	SL 201	SL 202
SL 199	NO WALL SL 200	SL 191	SL 192
SL 189	SL 190	SL 181	SL 182
SL 179	NO WALL SL 180	SL 171	SL 172
SL 169	SL 170	SL 161	SL 162
SL 159	NO WALL SL 160	NO WALL SL 151	SL 152
SL 149	NO WALL SL 150	SL 141	SL 142
SL 139	NO WALL SL 140	SL 131	SL 132
SL 129	SL 130	NO WALL SL 121	SL 122
CONTINUES DOWN TO LEVEL FOURTEEN (SEE SHEET 39)			

- ROOF LEVEL
- LEVEL THIRTY-FOUR
- LEVEL THIRTY-THREE
- LEVEL THIRTY-TWO
- LEVEL THIRTY-ONE
- LEVEL THIRTY
- LEVEL TWENTY-NINE
- LEVEL TWENTY-EIGHT
- LEVEL TWENTY-SEVEN
- LEVEL TWENTY-SIX
- LEVEL TWENTY-FIVE
- LEVEL TWENTY-FOUR
- LEVEL TWENTY-THREE
- LEVEL TWENTY-TWO
- LEVEL TWENTY-ONE
- LEVEL TWENTY
- LEVEL NINETEEN
- LEVEL EIGHTEEN
- LEVEL SEVENTEEN
- LEVEL SIXTEEN
- LEVEL FIFTEEN

**LEGEND**

SL - DENOTES STRATA LOT  
 LCP - DENOTES LIMITED COMMON PROPERTY

FILE: C:\PK3\11963-4F.DWG

DATED THIS 24th DAY OF June, 1999.

*[Signature]*

B.C.L.S.



SECTION B TO B'

STRATA PLAN LMS 3963

Scale 1:250



ALL DISTANCES ARE IN METRES AND DECIMALS THEREOF.

CONTINUES UP TO  
LEVEL FIFTEEN  
(SEE SHEET 35)

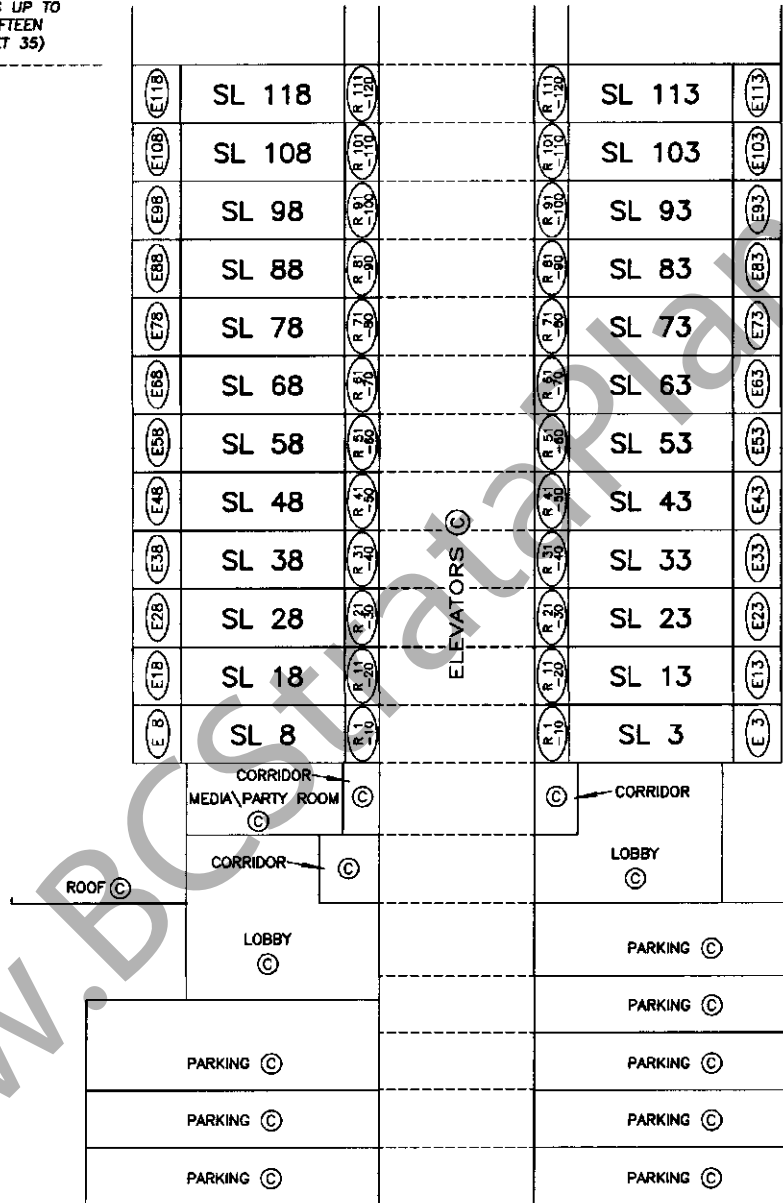

LEVEL FOURTEEN

LEVEL THIRTEEN

LEVEL TWELVE

LEVEL ELEVEN

LEVEL TEN

LEVEL NINE

LEVEL EIGHT

LEVEL SEVEN

LEVEL SIX

LEVEL FIVE

LEVEL FOUR

LEVEL THREE

LEVEL TWO

LEVEL ONE

PARKING LEVEL ONE

PARKING LEVEL TWO

PARKING LEVEL THREE

PARKING LEVEL FOUR

PARKING LEVEL FIVE

**LEGEND**

- SL - DENOTES STRATA LOT
- (C) - COMMON PROPERTY
- LCP - DENOTES LIMITED COMMON PROPERTY
- (R 121 -130) - DENOTES CORRIDOR LCP FOR SL's 121 TO 130 (TYP.)
- (E12) - DENOTES ENCLOSED BALCONY PT SL 12 (TYP.)

FILE: C:\PK3\11963-4F.DWG

DATED THIS 24<sup>th</sup> DAY OF

June, 1999.

*Job*

B.C.L.S.

**SECTION C TO C'**

**STRATA PLAN LMS 3963**

Scale 1:250



ALL DISTANCES ARE IN METRES AND DECIMALS THEREOF.

CONTINUES UP TO  
LEVEL FIFTEEN  
(SEE SHEET 36)

SL 119	NO WALL	SL120	SL 111	SL 112
SL 109		SL110	SL 101	SL 102
SL 99		SL100	SL 91	SL 92
SL 89		SL 90	SL 81	SL 82
SL 79		SL 80	SL 71	SL 72
SL 69		SL 70	SL 61	SL 62
SL 59		SL 60	SL 51	SL 52
SL 49		SL 50	SL 41	SL 42
SL 39		SL 40	SL 31	SL 32
SL 29		SL 30	SL 21	SL 22
SL 19		SL 20	SL 11	SL 12
SL 9		SL 10	SL 1	SL 2
MEDIA PARTY ROOM Ⓢ		GUEST ROOM Ⓢ	LIBRARY OFFICE Ⓢ	
CONFERENCE ROOM Ⓢ		CORRIDOR Ⓢ		LANDSCAPING Ⓢ
ELECTRICAL ROOM Ⓢ		PARKING Ⓢ		
		STORAGE Ⓢ		
		PARKING Ⓢ		
		PARKING Ⓢ		
		PARKING Ⓢ		

LEVEL FOURTEEN

LEVEL THIRTEEN

LEVEL TWELVE

LEVEL ELEVEN

LEVEL TEN

LEVEL NINE

LEVEL EIGHT

LEVEL SEVEN

LEVEL SIX

LEVEL FIVE

LEVEL FOUR

LEVEL THREE

LEVEL TWO

LEVEL ONE

PARKING LEVEL ONE

PARKING LEVEL TWO

PARKING LEVEL THREE

PARKING LEVEL FOUR

PARKING LEVEL FIVE

**LEGEND**

- SL - DENOTES STRATA LOT
- Ⓢ - COMMON PROPERTY
- LCP - DENOTES LIMITED COMMON PROPERTY

FILE: C:\PK3\11963-4F.DWG

DATED THIS 24<sup>th</sup> DAY OF

June, 1999.

[Signature]  
B.C.L.S.