

STRATA PLAN OF PARCEL A
BLOCK 6 D. L. 185 GP 1
N. W. D. PLAN BCP4160

STRATA PLAN BCS 1180

REF NO. BX 116010-138

City of Vancouver
B. C. G. S. 92G.025

Strata Plan BCS 1180
Deposited and Registered in the Land
Title Office at New Westminster, B. C.
This 28th Day of FEB., 2005.

I. MacDonnell /os
Deputy Registrar

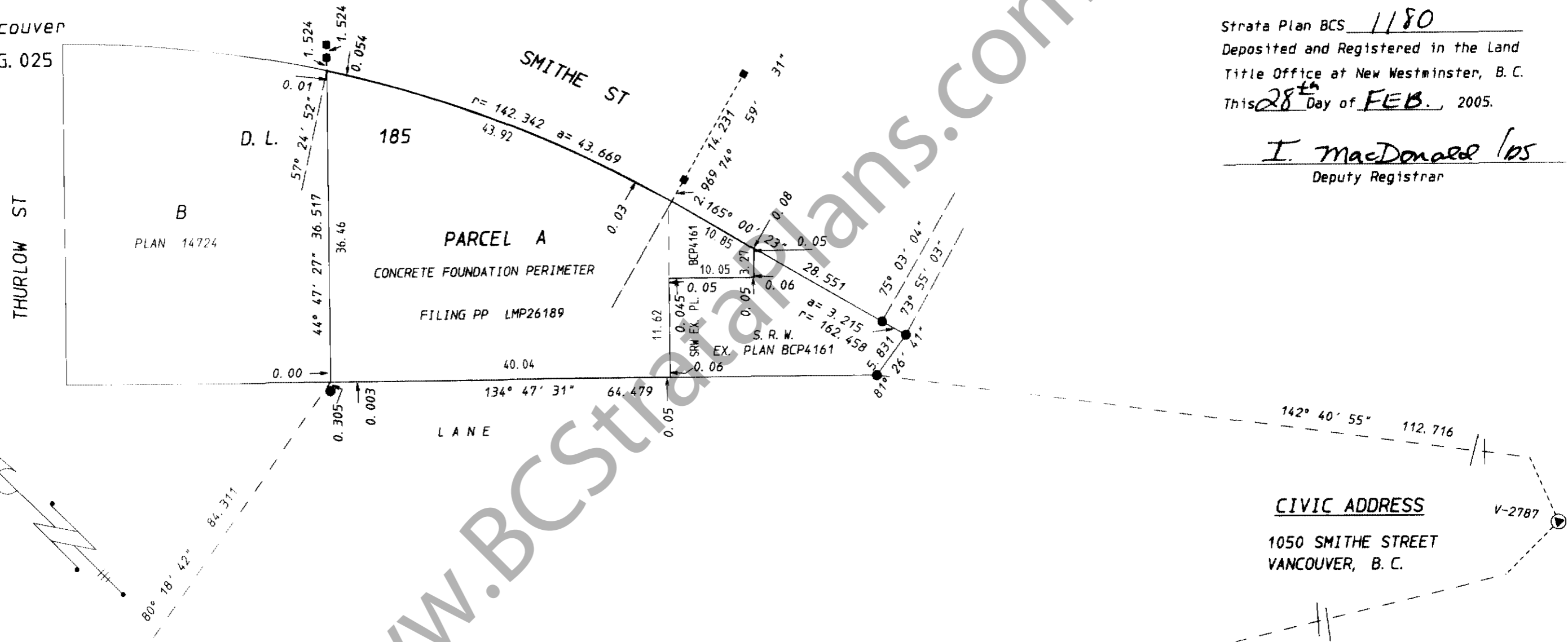

CIVIC ADDRESS
1050 SMITHE STREET
VANCOUVER, B. C.

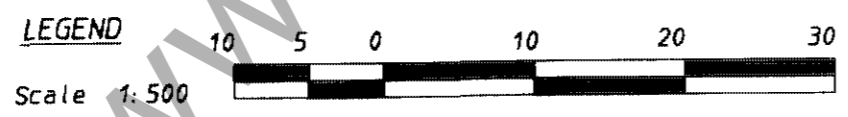

This Plan Lies Within the
Greater Vancouver Regional District

Caffo Land Surveying Ltd.
B. C. Land Surveyors
2027 East 50th Avenue
Vancouver, B. C. V5P 1V4
(fax) 604-327-2395
325-2696

JOB File No: V2076s1

All dimensions are expressed as
Grid Bearings are derived from Observations between
MON V-2770 and MON V-2787 integrated Survey Area-number 31

Integrated Survey Area NO. 31
CITY OF VANCOUVER

This plan shows ground
level measured distances.
Prior to computation of U. T. M.
co-ordinates, multiply by
combined factor 0.9995982

I Diego Caffo, a British Columbia Land Surveyor,
of the City of Vancouver, in British Columbia,
certify that I was present at and personally
superintended the survey represented by this plan
and that the survey and plan are correct. The
The field survey was completed on the 2ND day of MARCH 2005
The plan was completed and checked, and the checklist
filed under No. 28077 on the 2ND day of MARCH 2005

D. Caffo B. C. L. S.
ORIGINAL

STRATA PLAN BCS 1180

STERLING RESIDENCES INC.
INC. NO. 452012

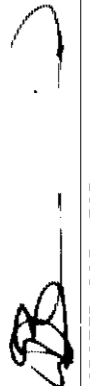
AUTHORIZED SIGNATORY
PRINT NAME DINO BONNIS

AUTHORIZED SIGNATORY
PRINT NAME

BARRISTER + SOLICITOR
Occupation of Witness

WITNESSES

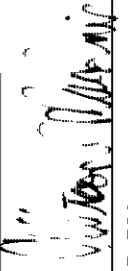
WITNESS
PRINT NAME ALLISON MACINNIS
2100 - 1075 WEST GEORGIA ST.
VANCOUVER, BC V6E 3G2
Address of Witness

623765 BRITISH COLUMBIA LTD.
INC. NO. 623765



AUTHORIZED SIGNATORY
PRINT NAME KEITH E. DURNELL

AUTHORIZED SIGNATORY
PRINT NAME

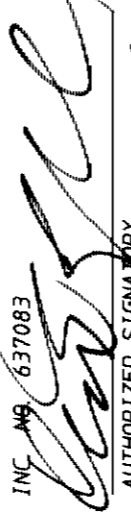

WITNESS
PRINT NAME ROBERTA COOPER
1300-777 DUNSMUIR ST
VANCOUVER BC V3Y1K2
Address of Witness

LEGAL SECRETARY
Occupation of Witness

637083 BRITISH COLUMBIA LTD.
INC. NO. 637083



AUTHORIZED SIGNATORY
PRINT NAME KEITH E. DURNELL

AUTHORIZED SIGNATORY
PRINT NAME

WITNESS
PRINT NAME ROBERTA COOPER
1300-777 DUNSMUIR ST
VANCOUVER BC V3Y1K2
Address of Witness

LEGAL SECRETARY
Occupation of Witness

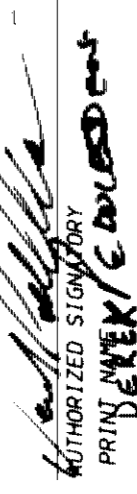
PEOPLES TRUST COMPANY
INC. NO. 33943A

AUTHORIZED SIGNATORY
PRINT NAME MARRIE BARTLEY

AUTHORIZED SIGNATORY
PRINT NAME DEREK E. DURNELL

WITNESS
PRINT NAME CINDY SHIELDS
1400 - 877 DUNSMUIR ST
VANCOUVER BC V6C 2K4
Address of Witness

ASSISTANT MANAGER
Occupation of Witness

I, Diego Caffo, British Columbia
land surveyor, certify that the building
included in this strata plan have not as of

FEBRUARY 17 2005

been previously occupied.



B. C. L. S.

I, Diego Caffo, British Columbia land surveyor
certify that the buildings shown on this strata plan
are within the external boundaries of the land that
is the subject of the strata plan.

Date: FEBRUARY 17, 2005.



B. C. L. S.

Caffo Land Surveying Ltd.

B. C. Land Surveyors
2027 East 50th Avenue
Vancouver, B. C. V5P 1V4
(fax) 604-327-2395

604-325-2696

JOB File No: V2076s2

ORIGINAL

DATE 07/17/05 DC B. C. L. S.

Scale 1:200

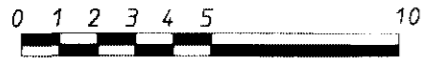

FLOOR PLAN

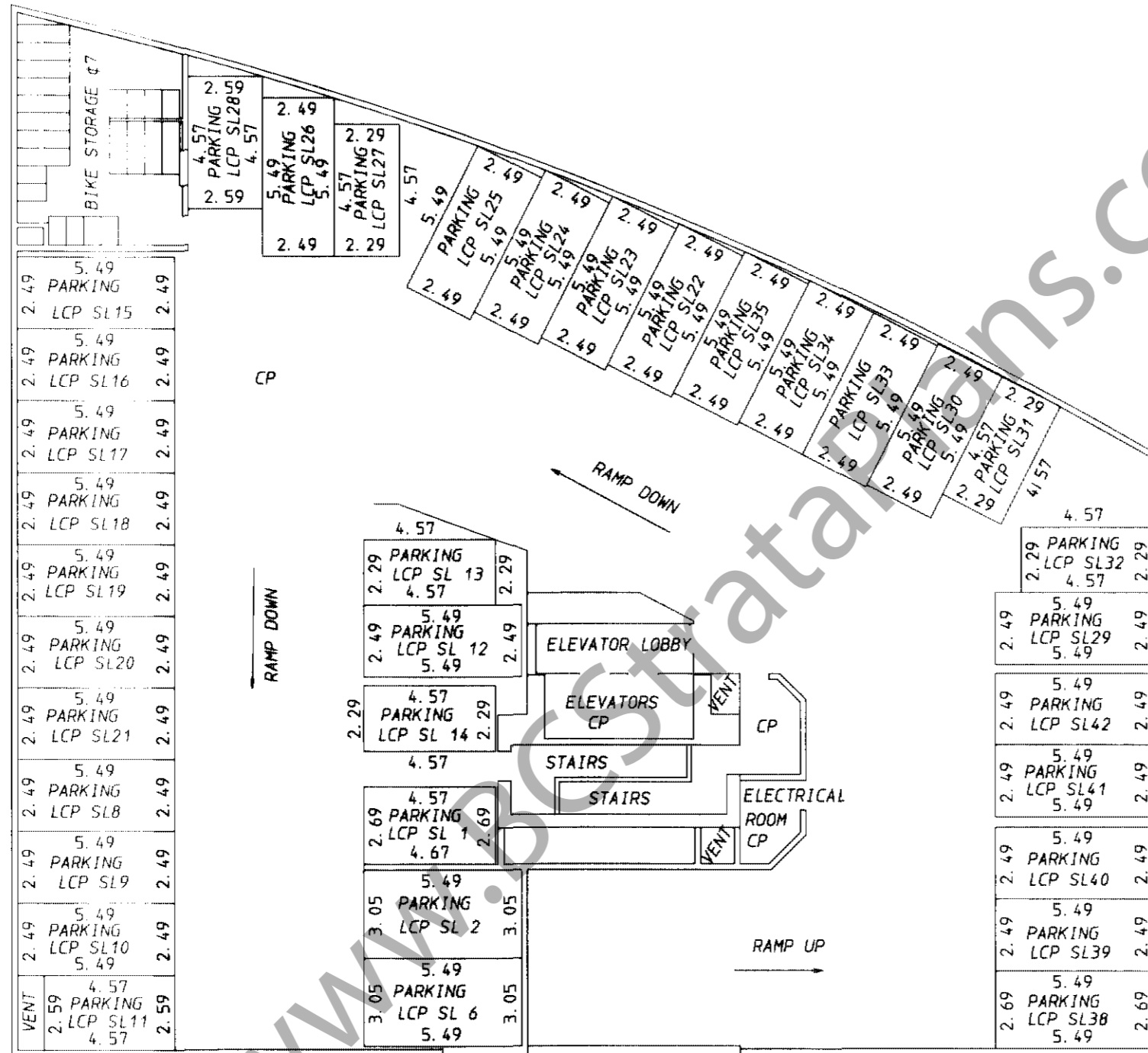

PARKING LEVEL P4

Caffo Land Surveying Ltd.

B. C. Land Surveyors
2027 East 50th Avenue
Vancouver, B. C. V5P 1V4
(fax) 604-327-2395

325-2696

File No: V2076S

ORIGINAL

DATED 02/17/05 M.C. B. C. L. S.

STRATA PLAN BCS 1180

Scale 1:200

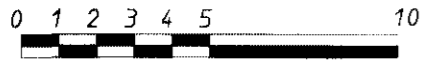

FLOOR PLAN

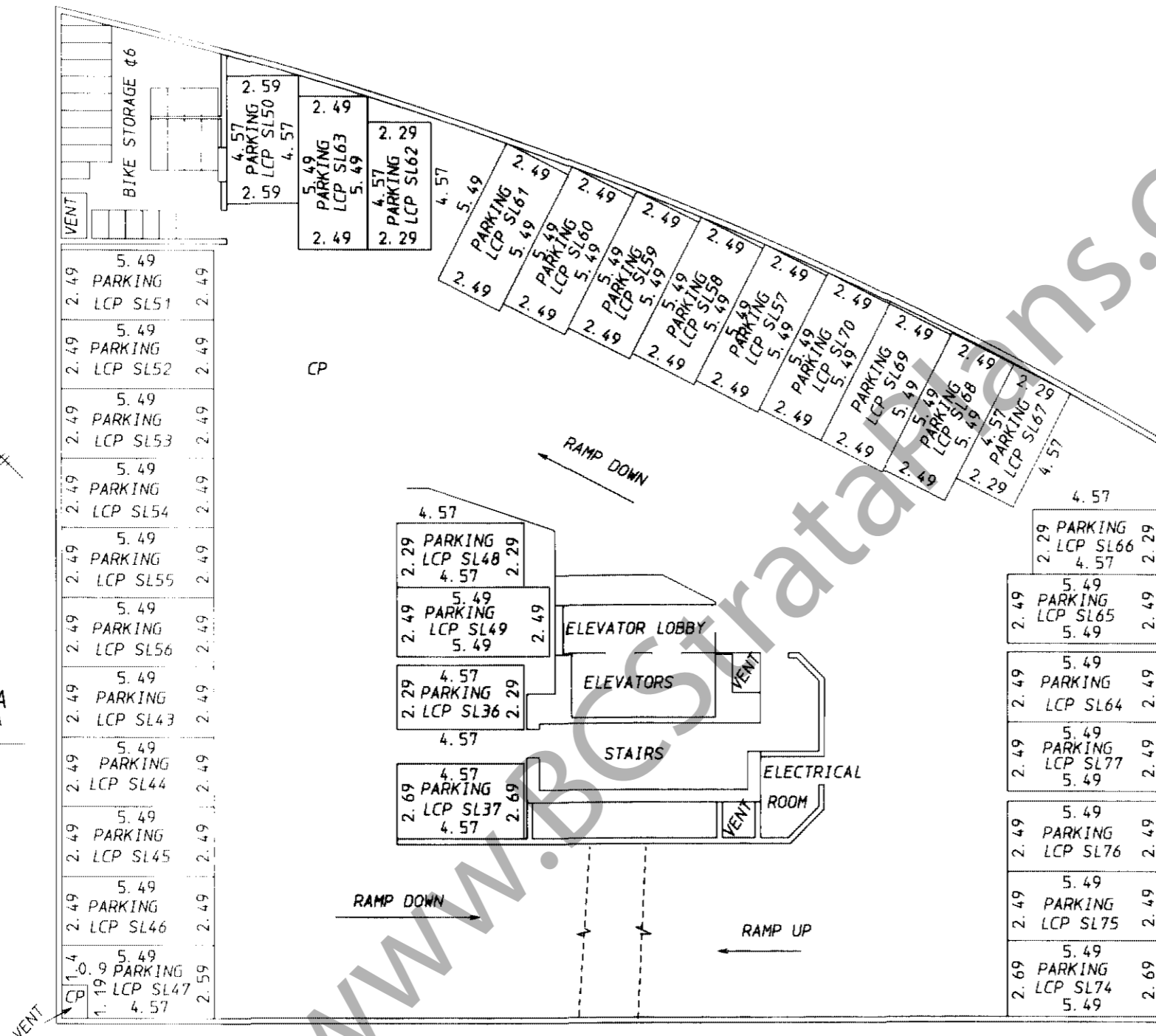

PARKING LEVEL 3

Caffo Land Surveying Ltd.

B. C. Land Surveyors
2027 East 50th Avenue
Vancouver, B. C. V5P 1V4
(fax) 604-327-2395

325-2696

File No: V2076S

ORIGINAL

DATED 02/17/05 P.C. B. C. L. S.

STRATA PLAN BCS 1180

Scale 1:200 0 1 2 3 4 5 10

FLOOR PLAN

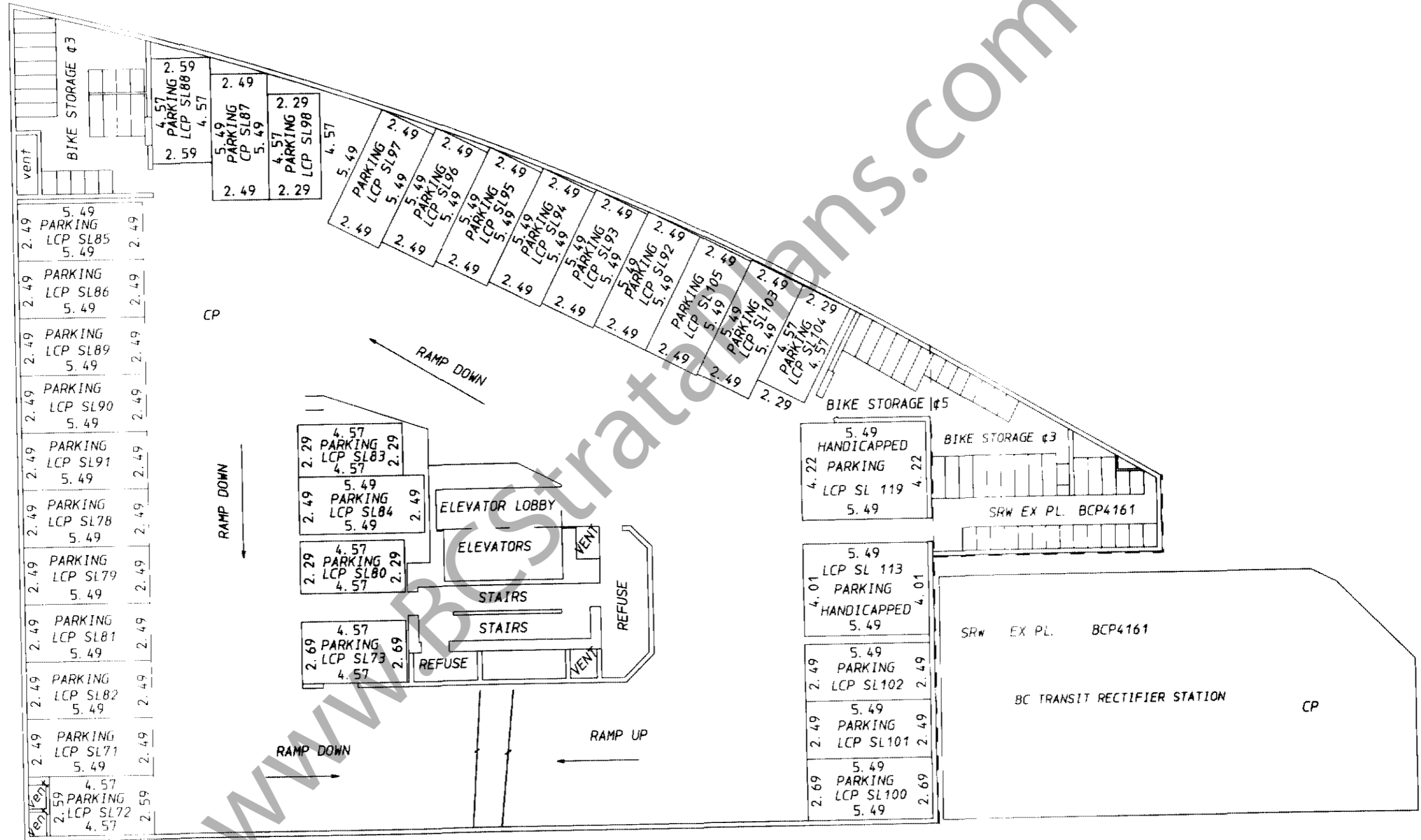

PARKING LEVEL P2

Caffo Land Surveying Ltd.

B. C. Land Surveyors
2027 East 50th Avenue
Vancouver, B. C. V5P 1V4
(fax) 604-327-2395

325-2696

File No: V2076S

ORIGINAL

DATED

02/17/05 P.C. B.C.L.S.

Scale 1:200

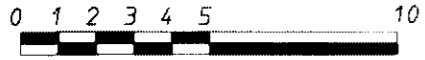

FLOOR PLAN

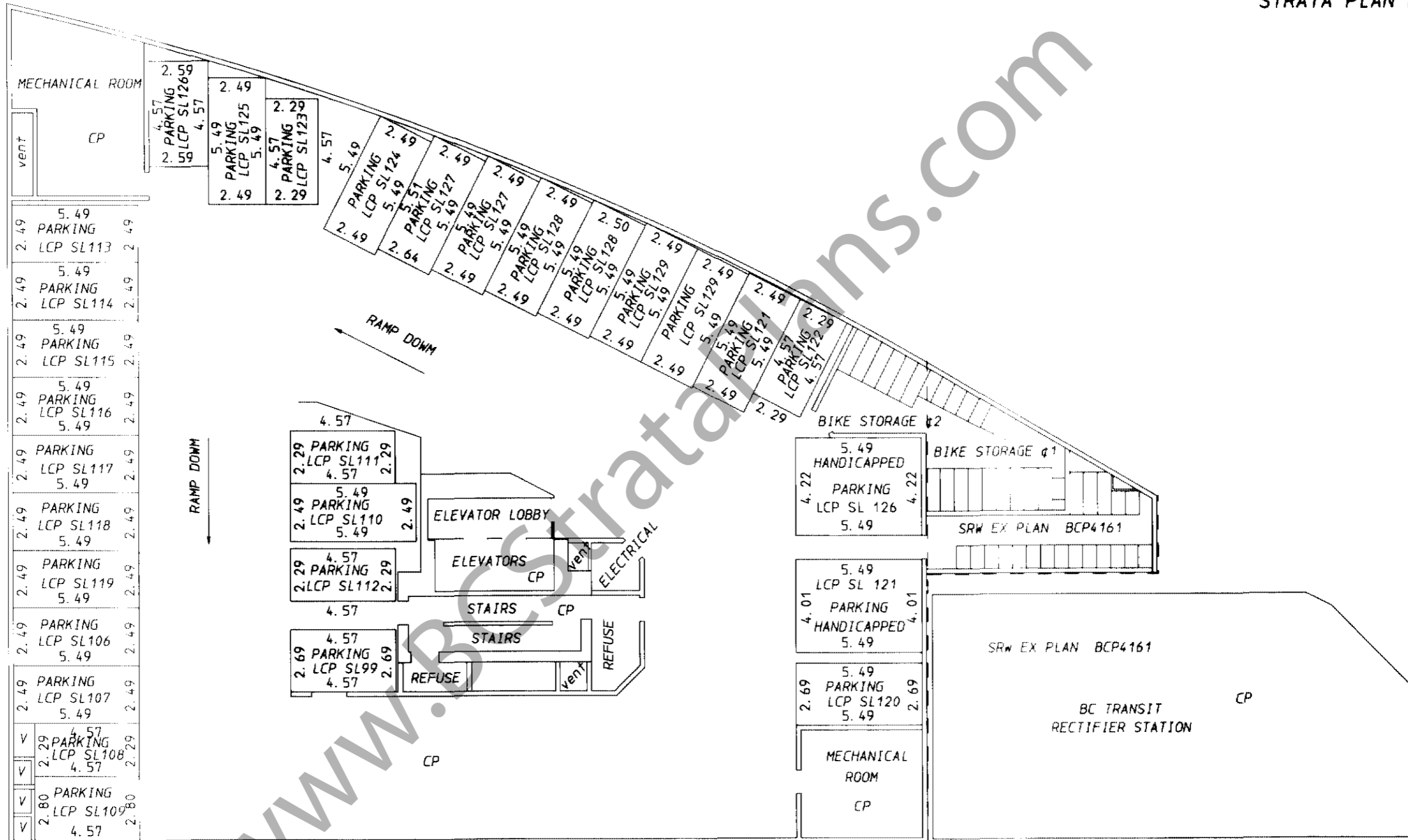

Caffo Land Surveying Ltd.

B. C. Land Surveyors
2027 East 50th Avenue
Vancouver, B. C. V5P 1V4
(fax) 604-327-2395

325-2696

File No: V2076S

PARKING LEVEL P1

ORIGINAL

DATED

02/17/05 P.C.

B. C. L. S.

Scale 1:200

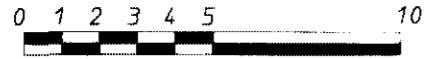

FLOOR PLAN

STRATA PLAN BCS 1180

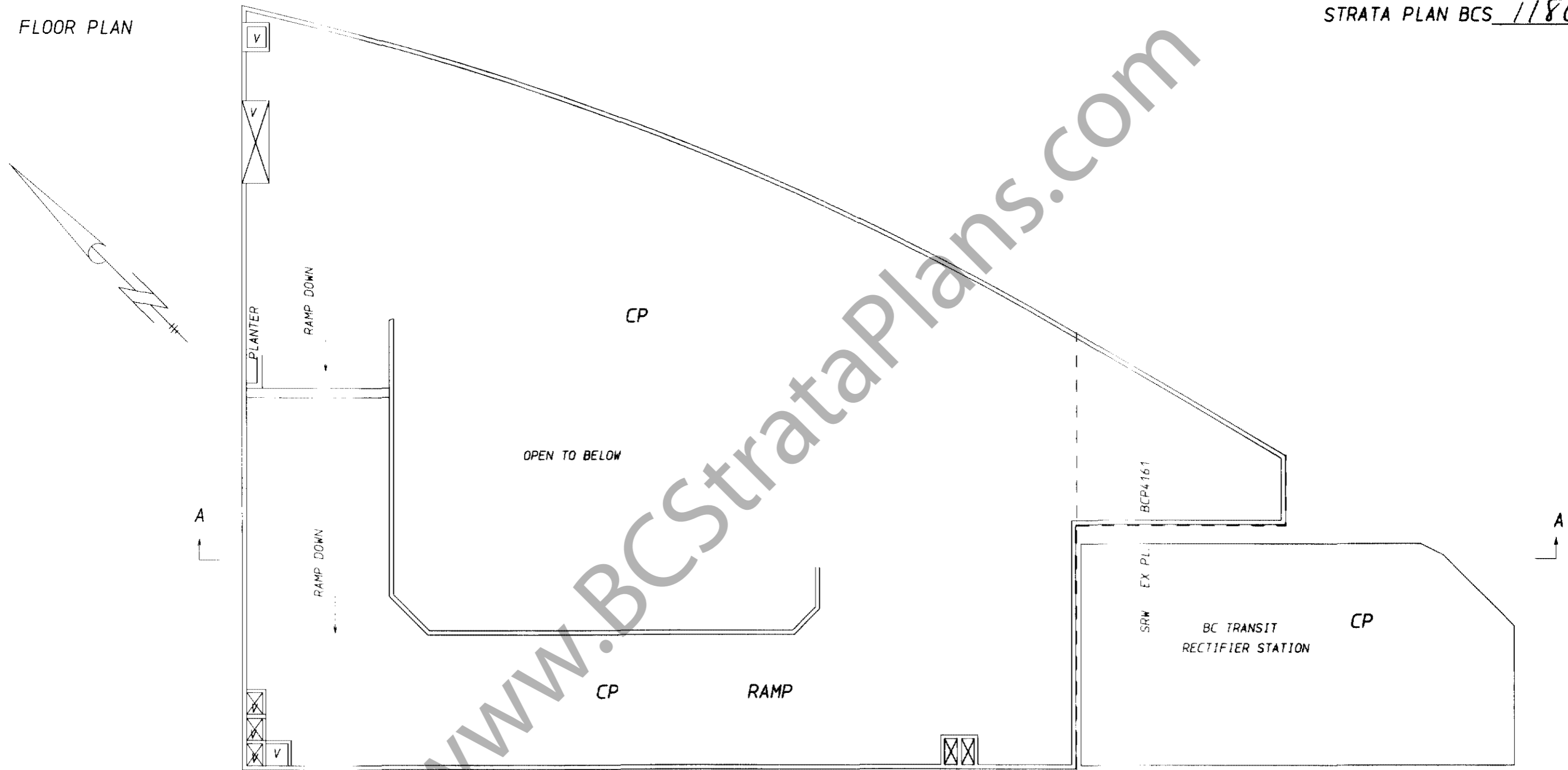

Caffo Land Surveying Ltd.

B. C. Land Surveyors
2027 East 50th Avenue
Vancouver, B. C. V5P 1V4
(fax) 604-327-2395

325-2696

RAMP TO LEVEL P1

File No: V2076S

ORIGINAL

DATED 02/17/05 P.C. B. C. L. S.

Scale 1:200

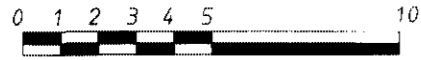

Sheet 8 of 31 Sheets

FLOOR PLAN

STRATA PLAN BCS 1180

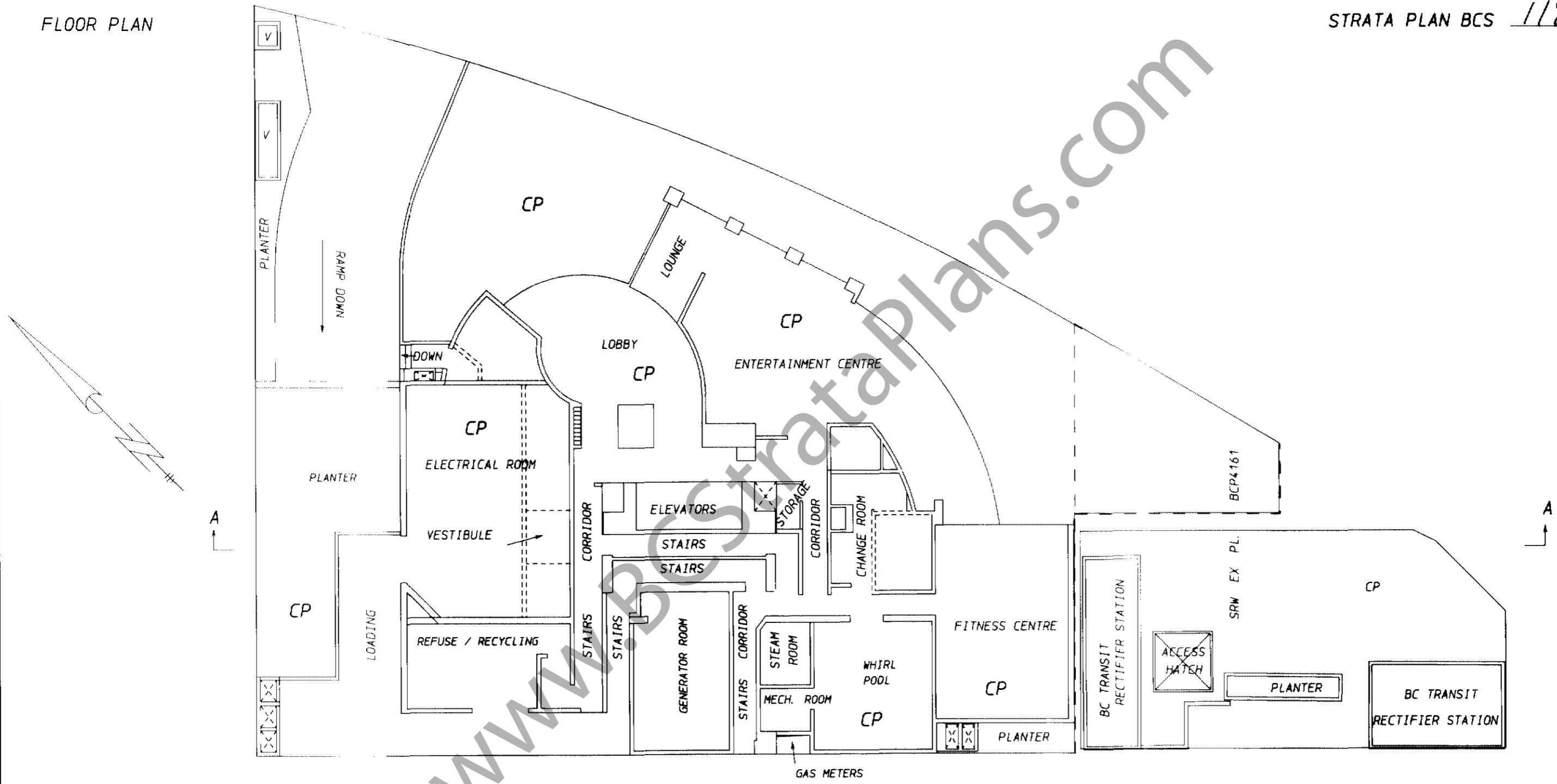

GROUND FLOOR

Caffo Land Surveying Ltd.

B. C. Land Surveyors
2027 East 50th Avenue
Vancouver, B. C. V5P 1V4
(fax) 604-327-2395

325-2696

File No: V-20765

ORIGINAL

DATED 02/17/05 P. C. B. C. L. S.

Scale 1:200

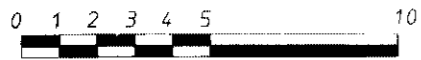

FLOOR PLAN

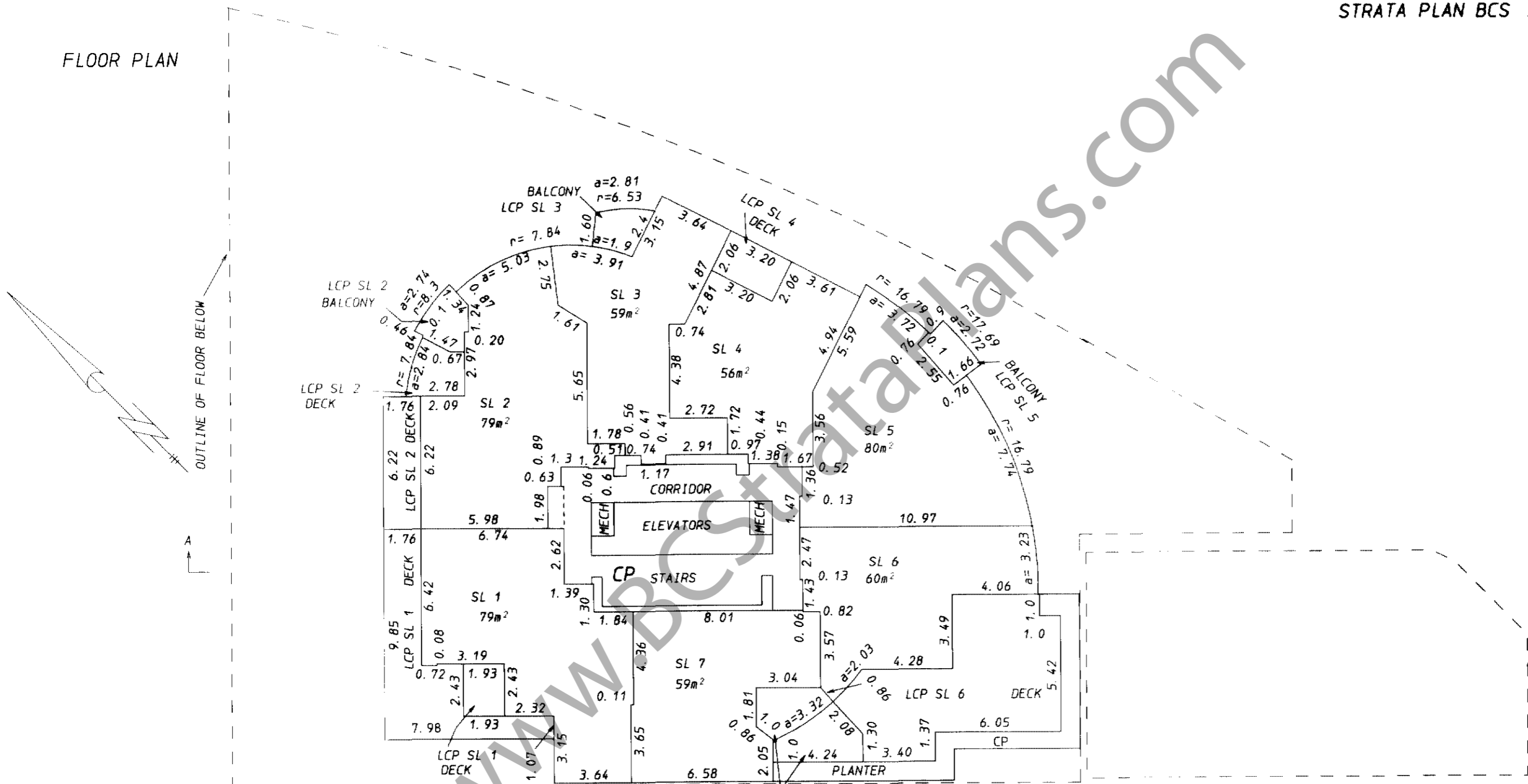

SECOND FLOOR

Caffo Land Surveying Ltd.

B. C. Land Surveyors
2027 East 50th Avenue
Vancouver, B. C. V5P 1V4
(fax) 604-327-2395

325-2696

File No: V-2076s

ORIGINAL

DATED 02/17/05 P. C. B. C. L. S.

Scale 1:200

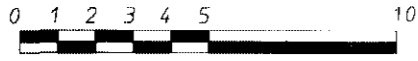

STRATA PLAN BCS 1180

FLOOR PLAN

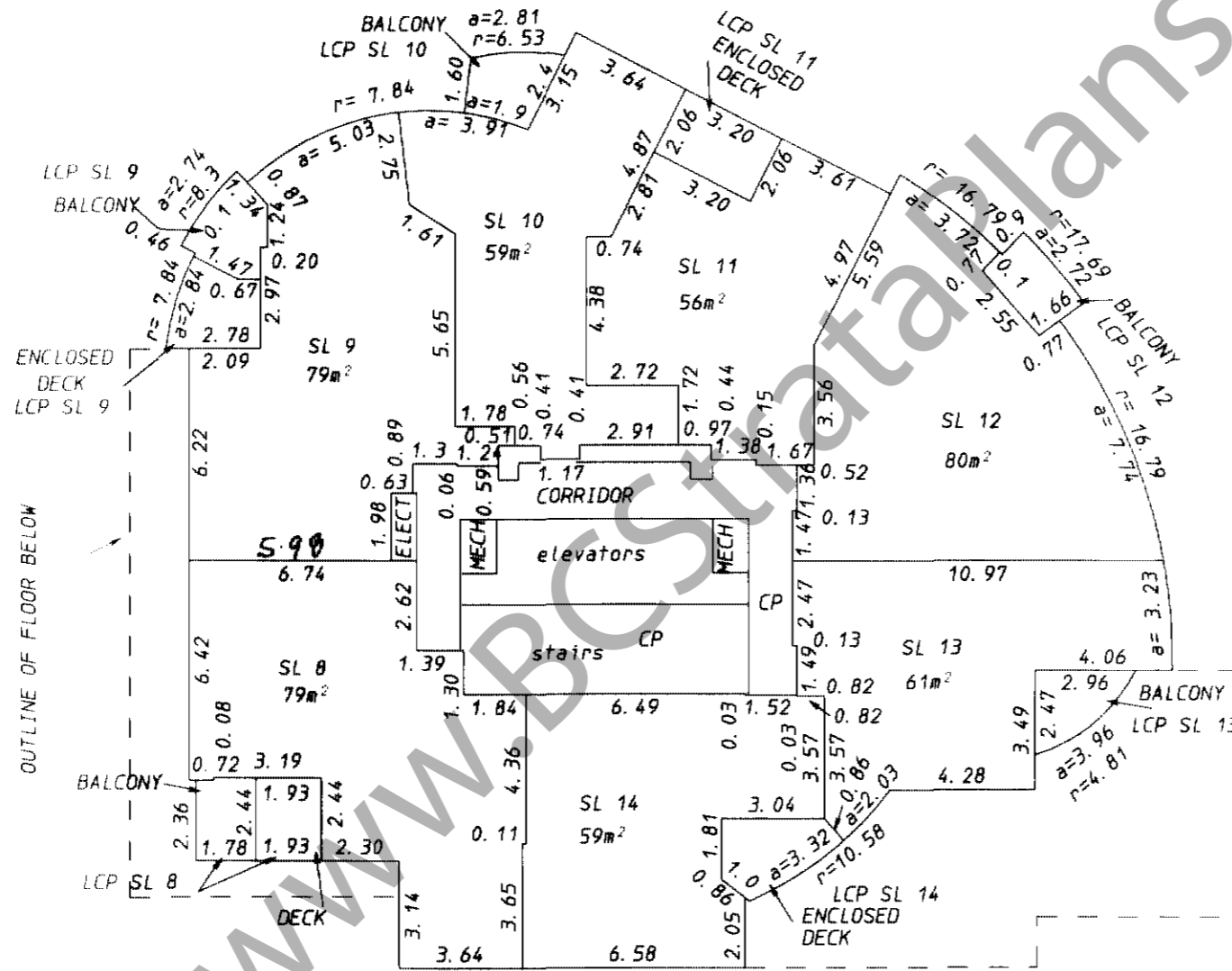

3rd FLOOR

Caffo Land Surveying Ltd.

B. C. Land Surveyors
2027 East 50th Avenue
Vancouver, B. C. V5P 1V4
(fax) 604-327-2395

325-2696

File No: V2076s

ORIGINAL

DATED

02/17/05 H.C.

B. C. L. S.

Scale 1:200

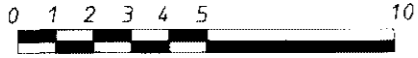

STRATA PLAN BCS 1180

FLOOR PLAN

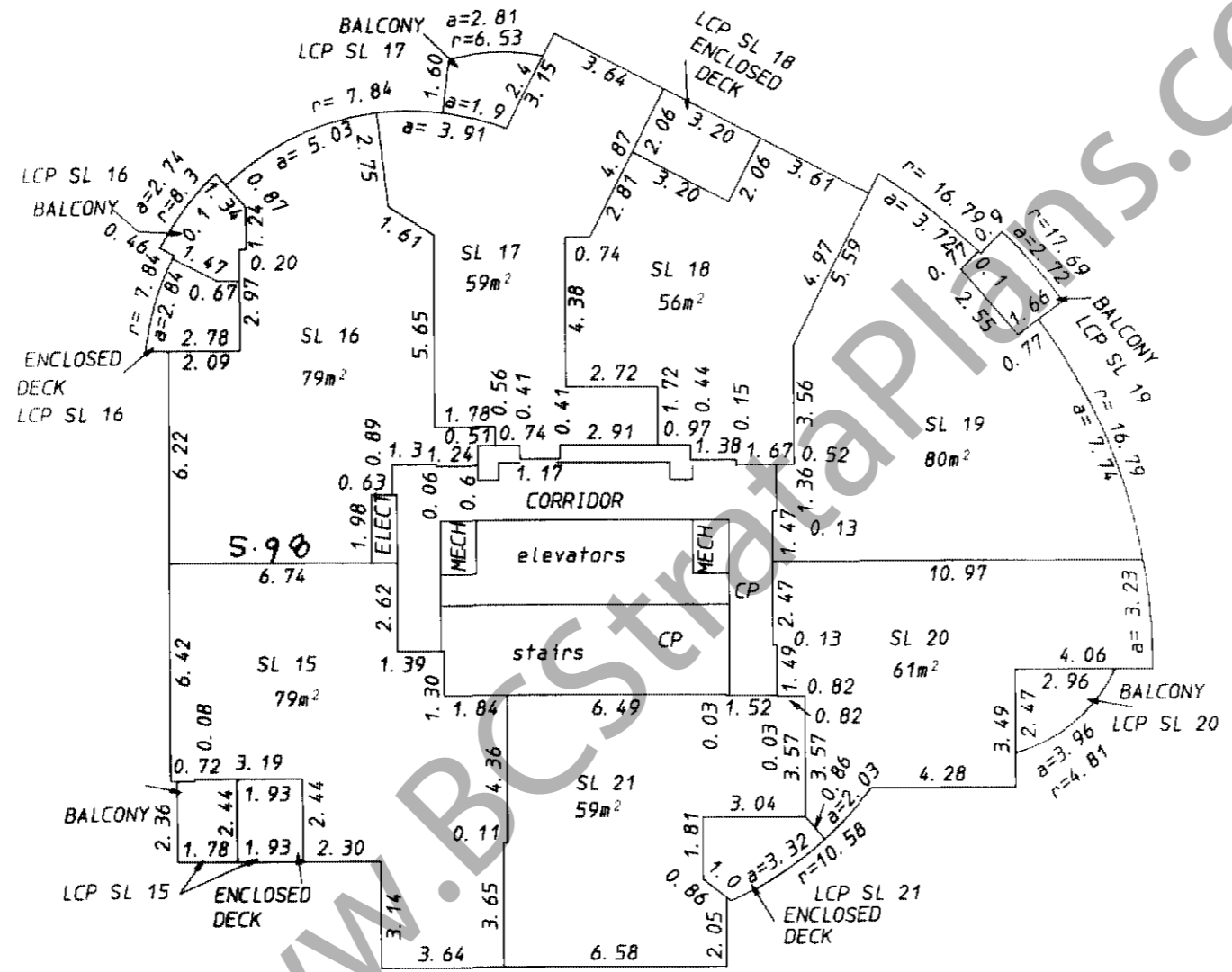

4th FLOOR

Caffo Land Surveying Ltd.

B. C. Land Surveyors
2027 East 50th Avenue
Vancouver, B. C. V5P 1V4
(fax) 604-327-2395

325-2696

File No: V2076s

ORIGINAL

DATED

02/17/05 P.C.

B. C. L. S.

Scale 1:200

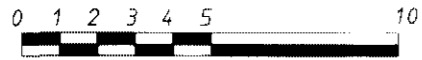

STRATA PLAN BCS 1180

FLOOR PLAN

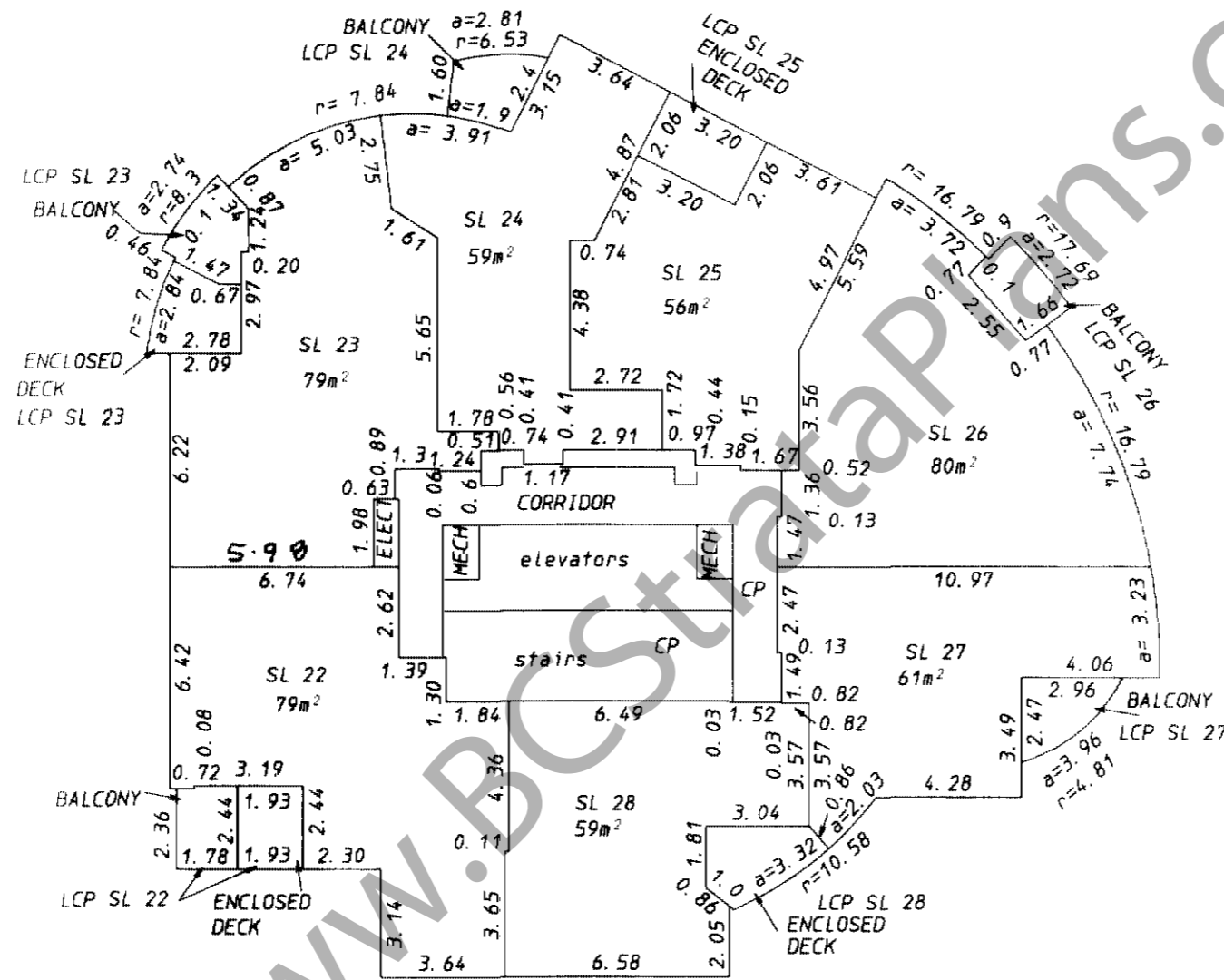

5th FLOOR

Caffo Land Surveying Ltd.

B. C. Land Surveyors
2027 East 50th Avenue
Vancouver, B. C. V5P 1V4
(fax) 604-327-2395

325-2696

File No. V2076s

ORIGINAL

DATED 02/17/05 P.C. B. C. L. S.

Scale 1:200

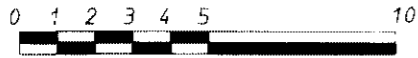

STRATA PLAN BCS 1180

FLOOR PLAN

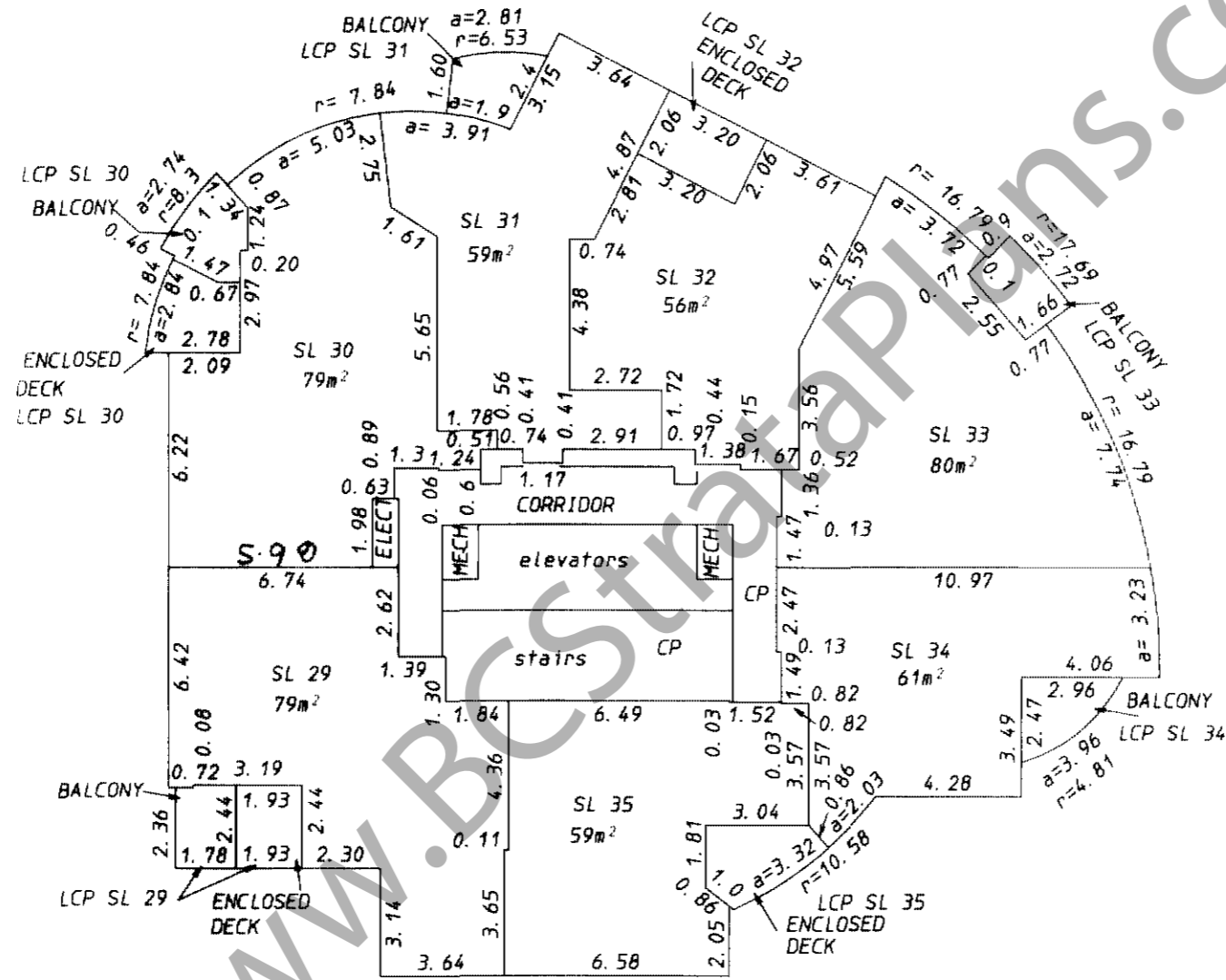

6th FLOOR

Caffo Land Surveying Ltd.

B. C. Land Surveyors
2027 East 50th Avenue
Vancouver, B. C. V5P 1V4
(fax) 604-327-2395

325-2696

File No: V2076s

ORIGINAL

DATED 02/17/05

B. C. L. S.

Scale 1:200



FLOOR PLAN

STRATA PLAN BCS 1180

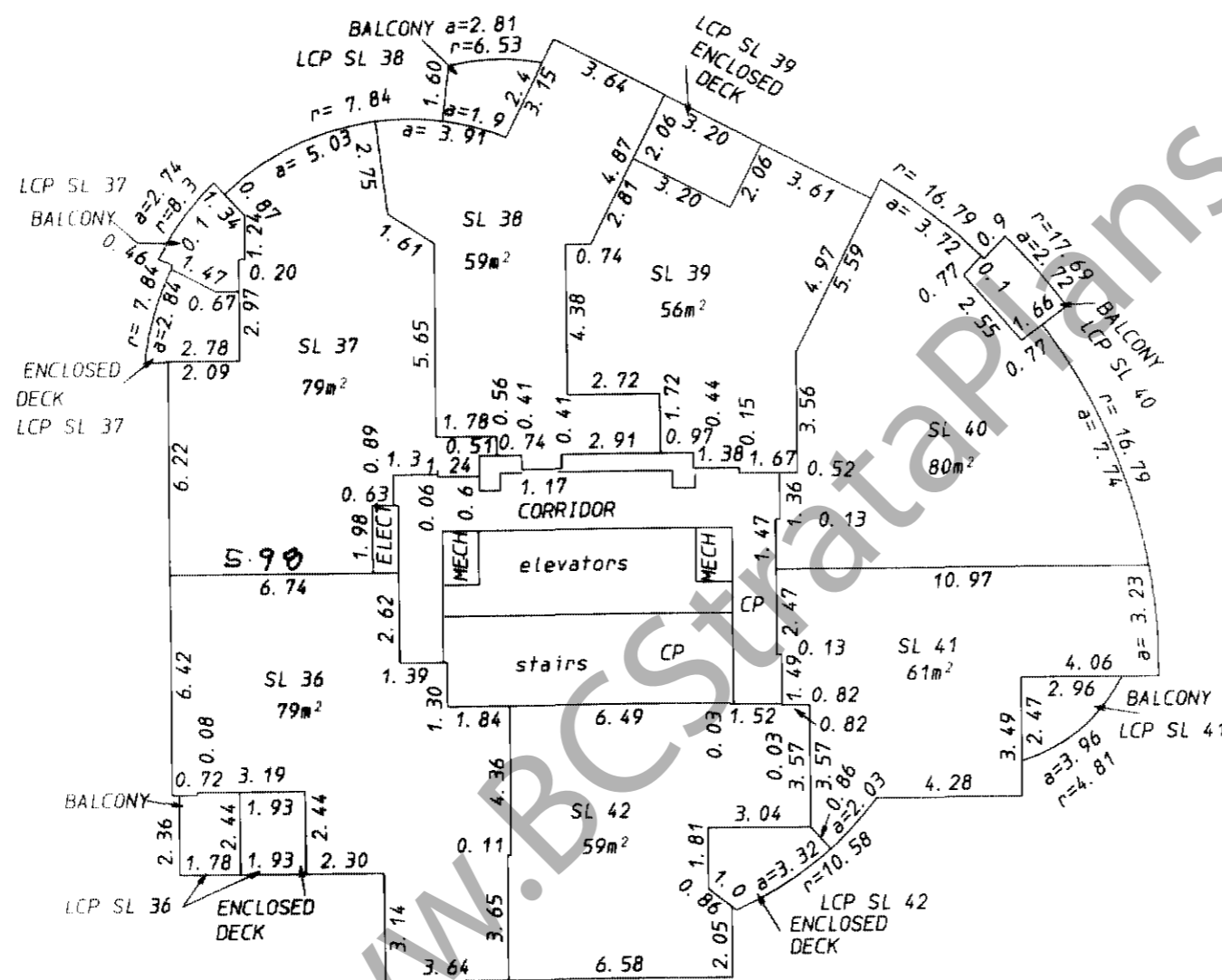

7th FLOOR

Caffo Land Surveying Ltd.

B. C. Land Surveyors
2027 East 50th Avenue
Vancouver, B. C. V5P 1V4
(fax) 604-327-2395

325-2696

File No: V-2076s

ORIGINAL

DATED 02/17/05 P.C. B. C. L. S.

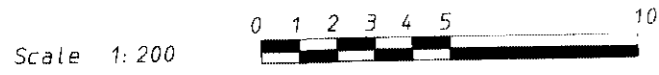

STRATA PLAN BCS 1180

FLOOR PLAN

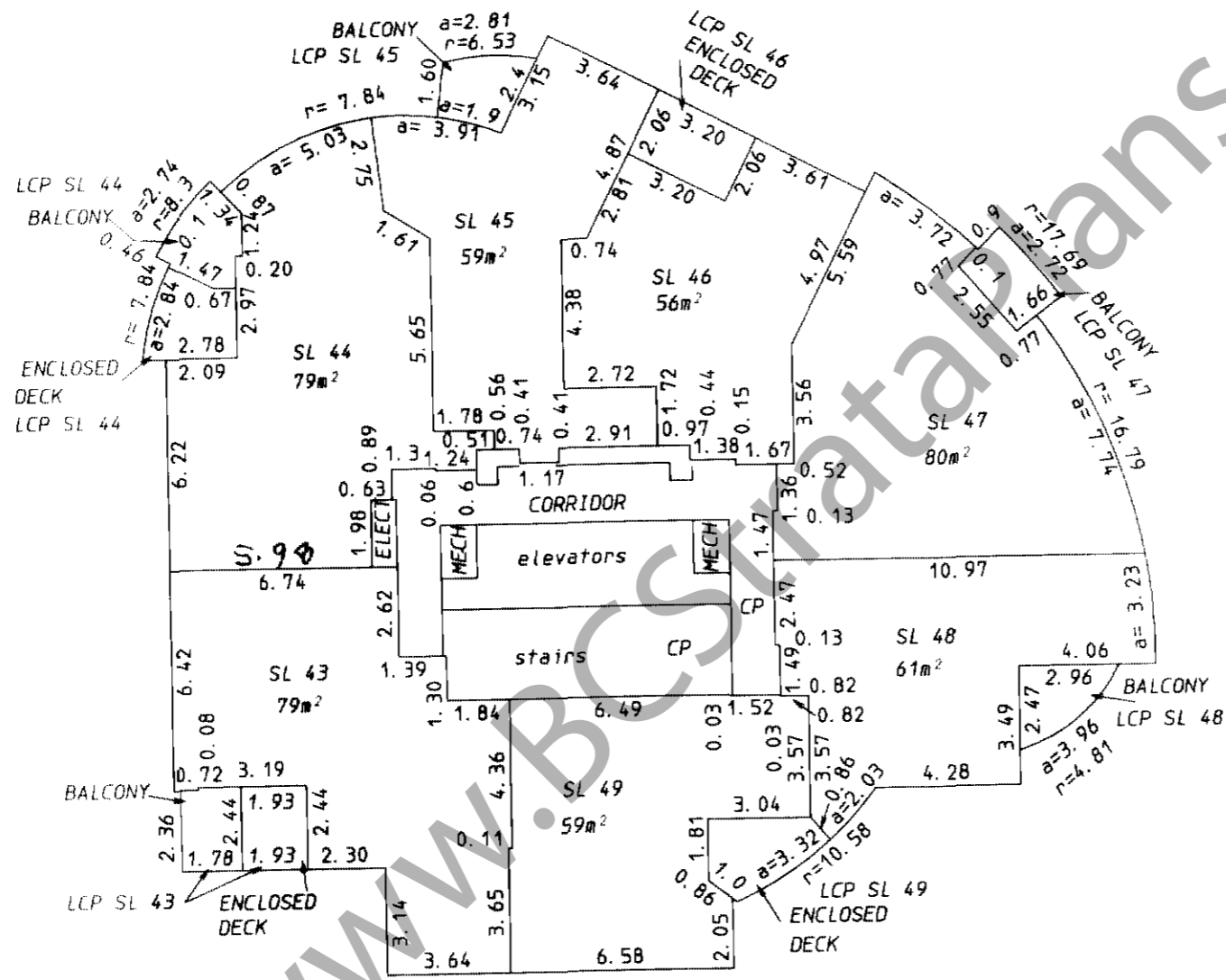

8th FLOOR

Caffo Land Surveying Ltd.

B. C. Land Surveyors
2027 East 50th Avenue
Vancouver, B. C. V5P 1V4
(fax) 604-327-2395

325-2696

File No: V-2076S

ORIGINAL

DATED 02/17/05 P.C. B. C. L. S.

Scale 1:200

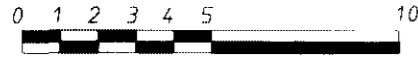

Sheet 16 of 31 Sheets

FLOOR PLAN

STRATA PLAN BCS 1180

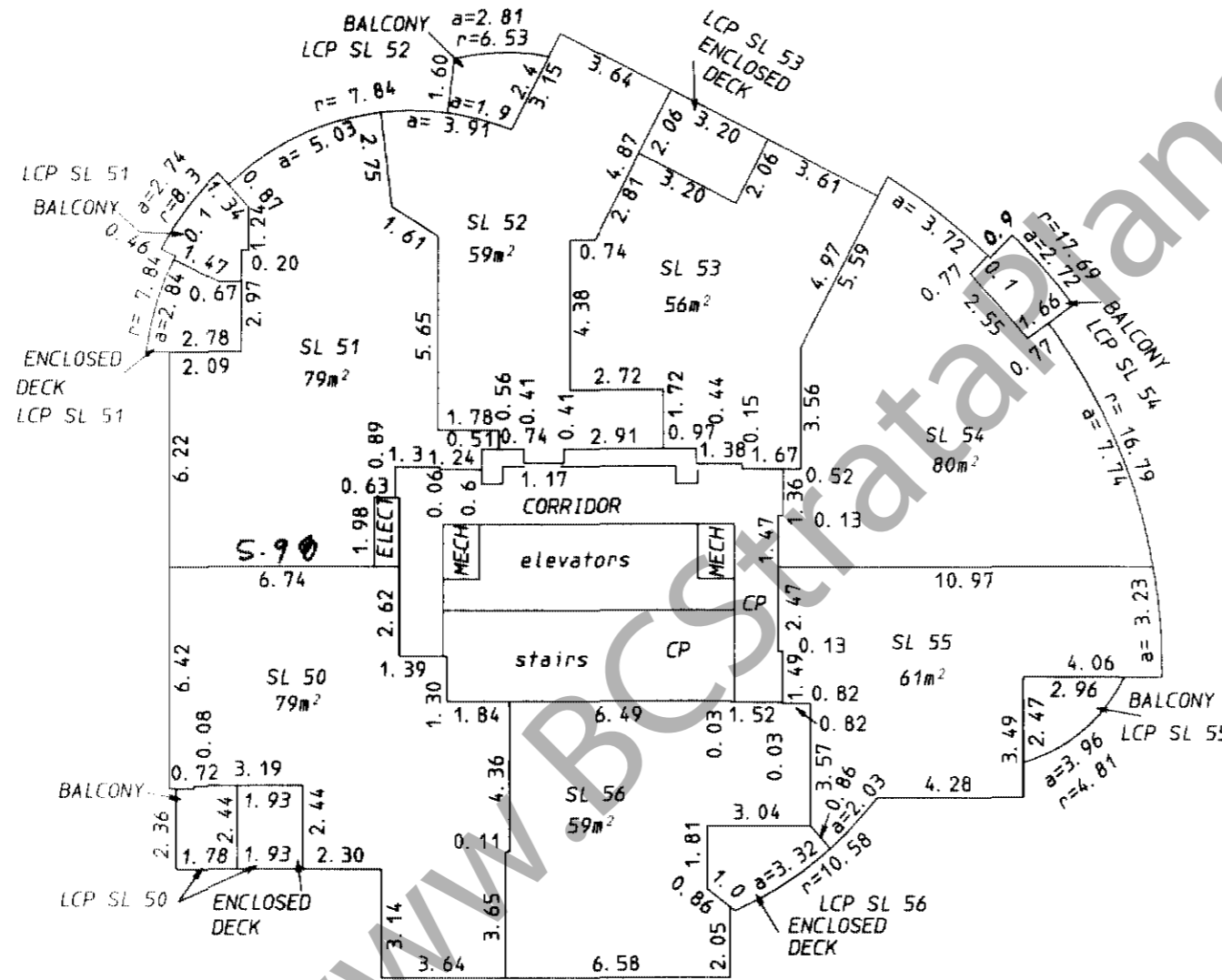

9th FLOOR

Caffo Land Surveying Ltd.

B. C. Land Surveyors
2027 East 50th Avenue
Vancouver, B. C. V5P 1V4
(fax) 604-327-2395

325-2696

File No: V-2076S

ORIGINAL

DATED 02/17/05 P.C. B. C. L. S.

Scale 1:200

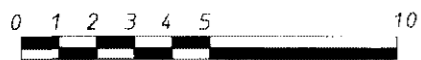

STRATA PLAN BCS 1180

FLOOR PLAN

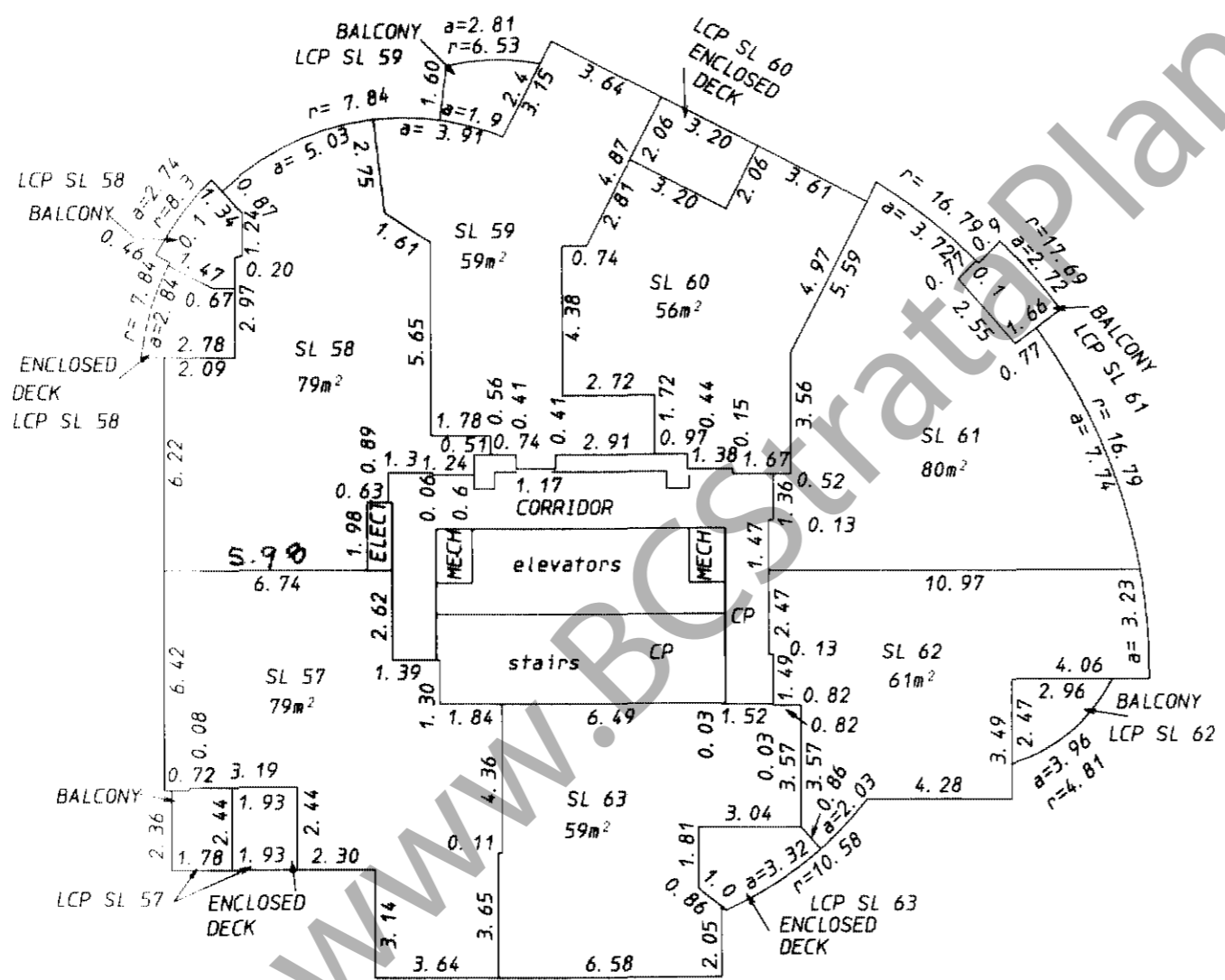

10th FLOOR

Caffo Land Surveying Ltd.

B. C. Land Surveyors
2027 East 50th Avenue
Vancouver, B. C. V5P 1V4
(fax) 604-327-2395

325-2696

File No: V-2076s

ORIGINAL

DATED

02/17/05 P.C.

B. C. L. S.

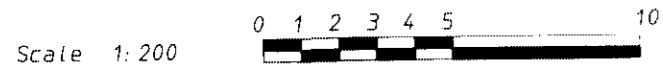

STRATA PLAN BCS 1180

FLOOR PLAN

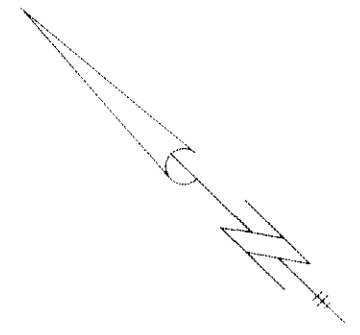
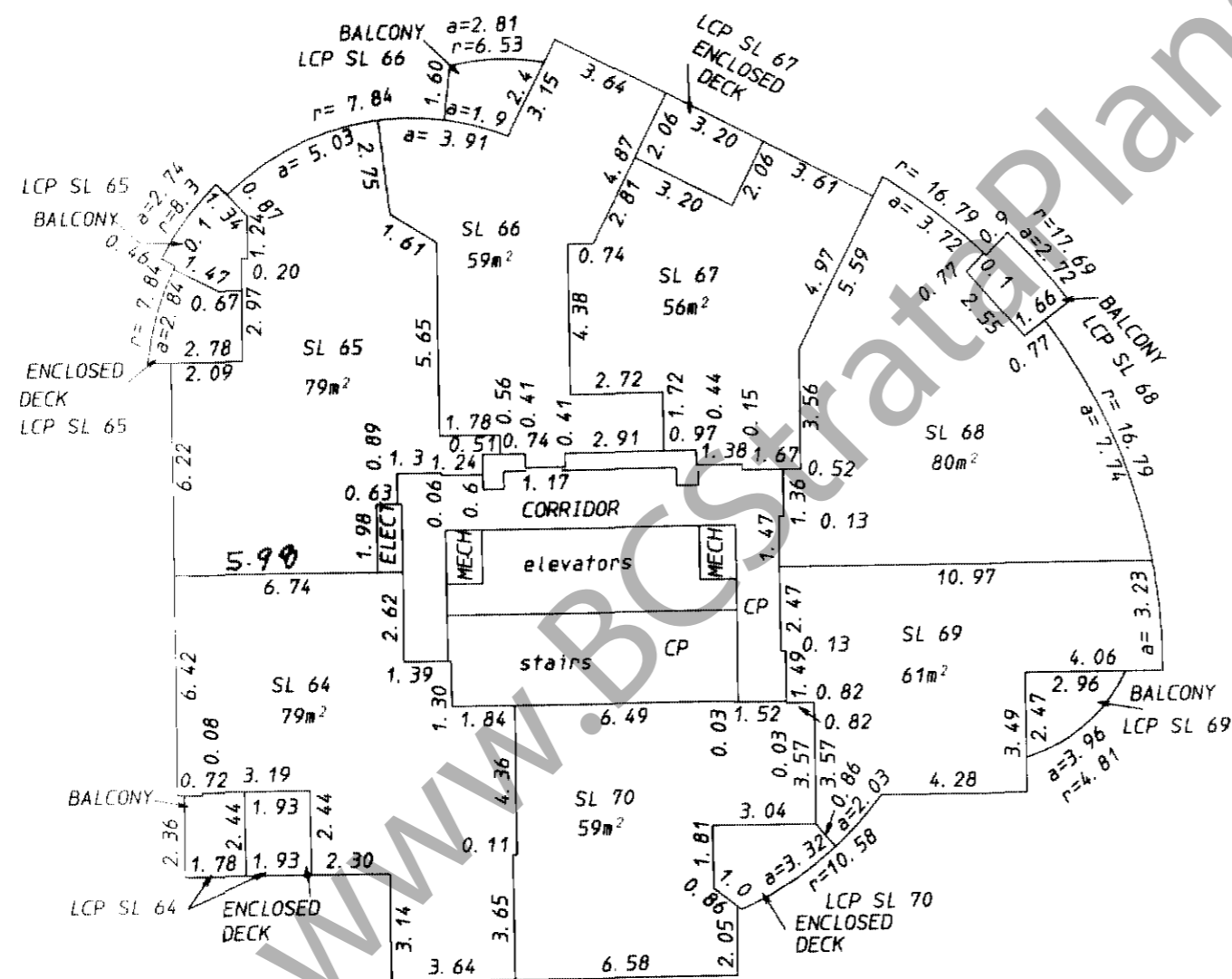

A ↑

↑ A

Caffo Land Surveying Ltd.

B. C. Land Surveyors
2027 East 50th Avenue
Vancouver, B. C. V5P 1V4
(fax) 604-327-2395

325-2696

11th FLOOR

ORIGINAL

DATED 02/17/05 P.C. B. C. L. S.

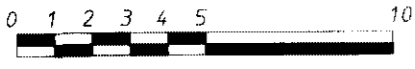
Scale 1:200 

FLOOR PLAN

STRATA PLAN BCS 1180

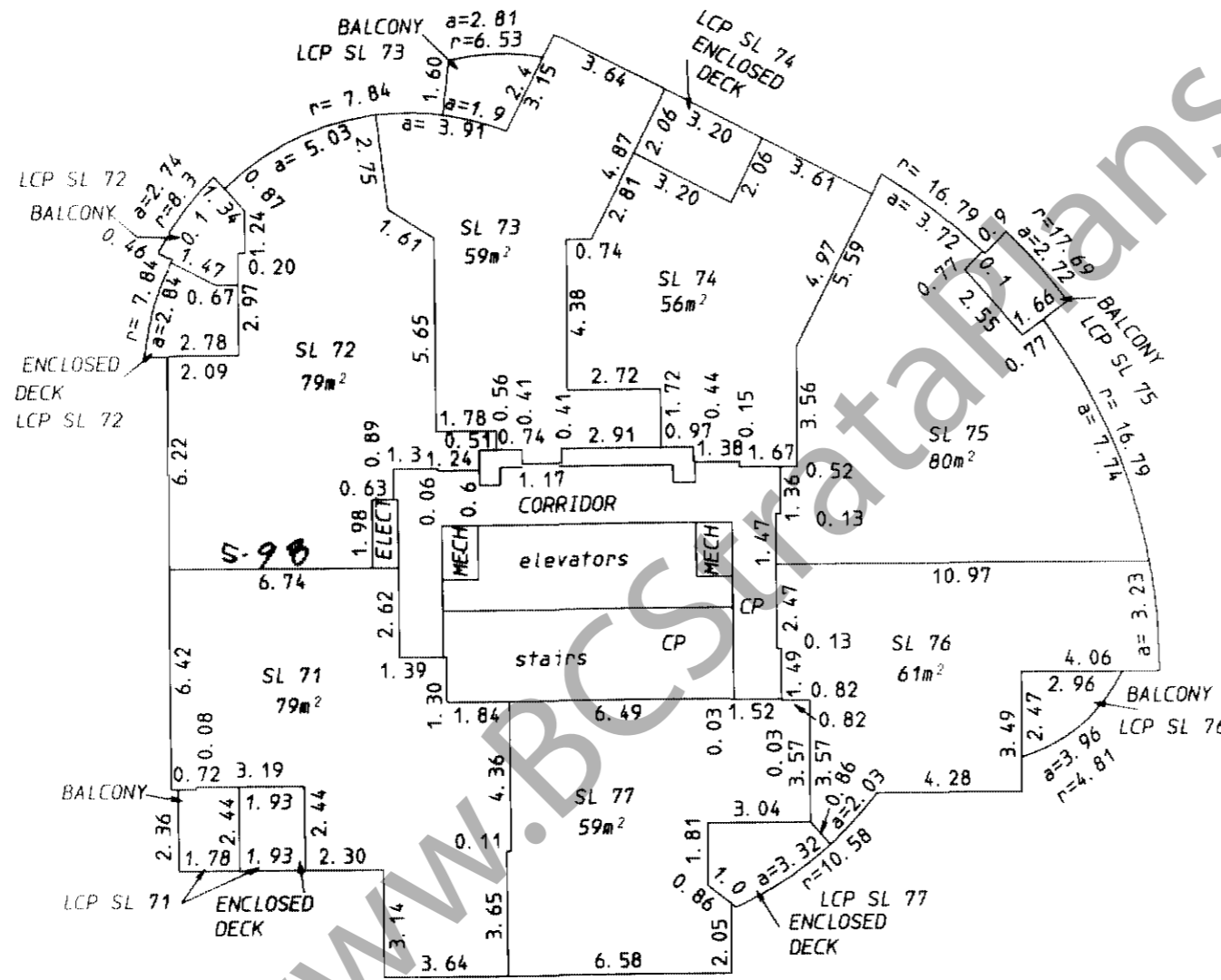

12th FLOOR

Caffo Land Surveying Ltd.

B. C. Land Surveyors
2027 East 50th Avenue
Vancouver, B. C. V5P 1V4
(fax) 604-327-2395

325-2696

File No: V-2076S

ORIGINAL

DATED 02/17/05 H.C. B. C. L. S.

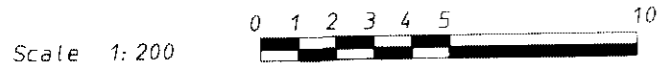

FLOOR PLAN

STRATA PLAN BCS 1180

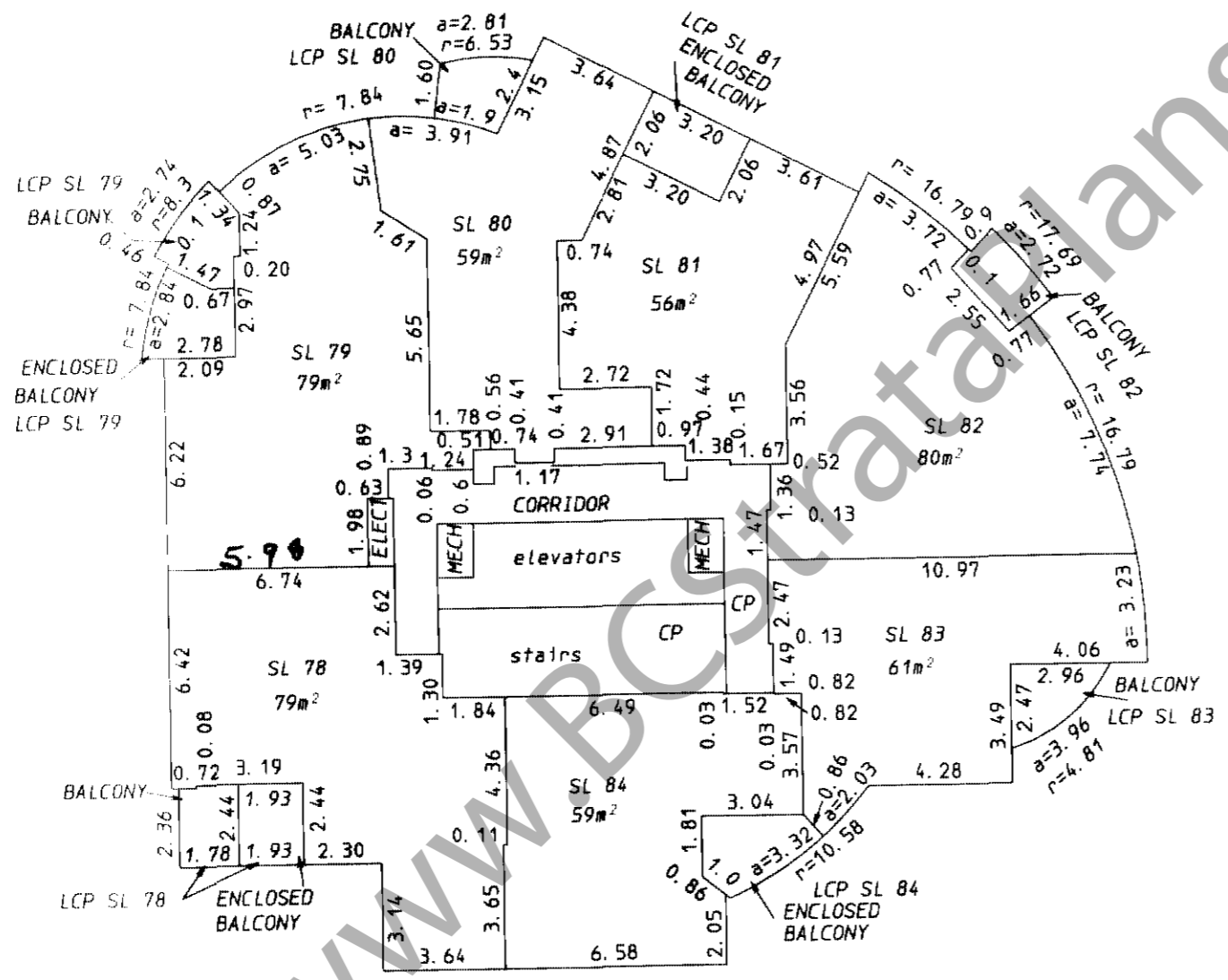

13th FLOOR

Caffo Land Surveying Ltd.

B. C. Land Surveyors
2027 East 50th Avenue
Vancouver, B. C. V5P 1V4
(fax) 604-327-2395

325-2696

File No: V-20765

ORIGINAL

DATED 02/17/05 M.C.

B. C. L. S.

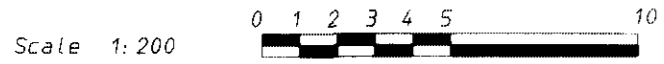

FLOOR PLAN

STRATA PLAN BCS 1180

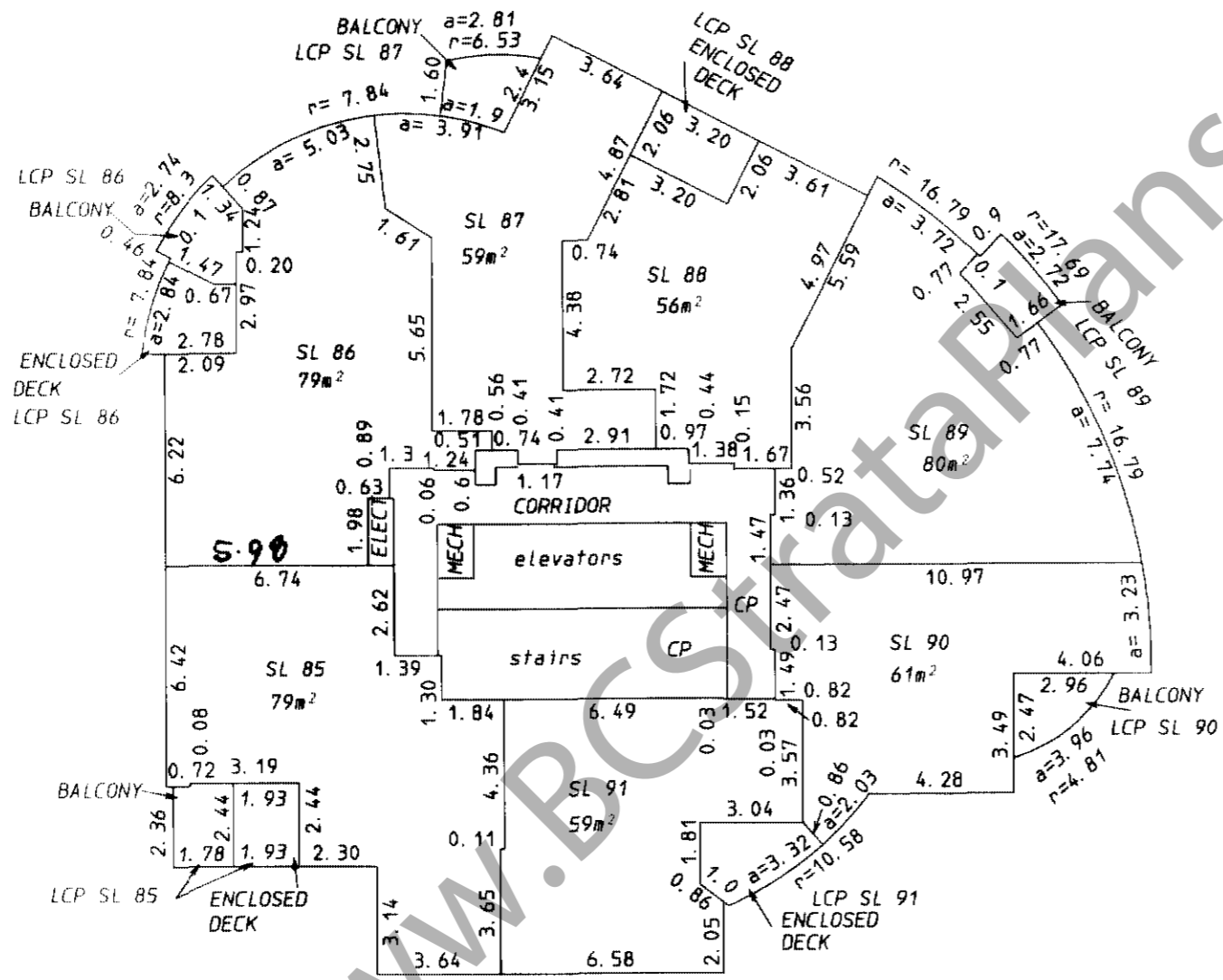

14th FLOOR

Caffo Land Surveying Ltd.

B. C. Land Surveyors
2027 East 50th Avenue
Vancouver, B. C. V5P 1V4
(fax) 604-327-2395

325-2696

File No: V-2076S

ORIGINAL

DATED

02/17/05 P.C.

B. C. L. S.

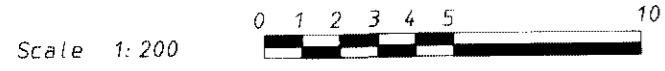

FLOOR PLAN

STRATA PLAN BCS 1180

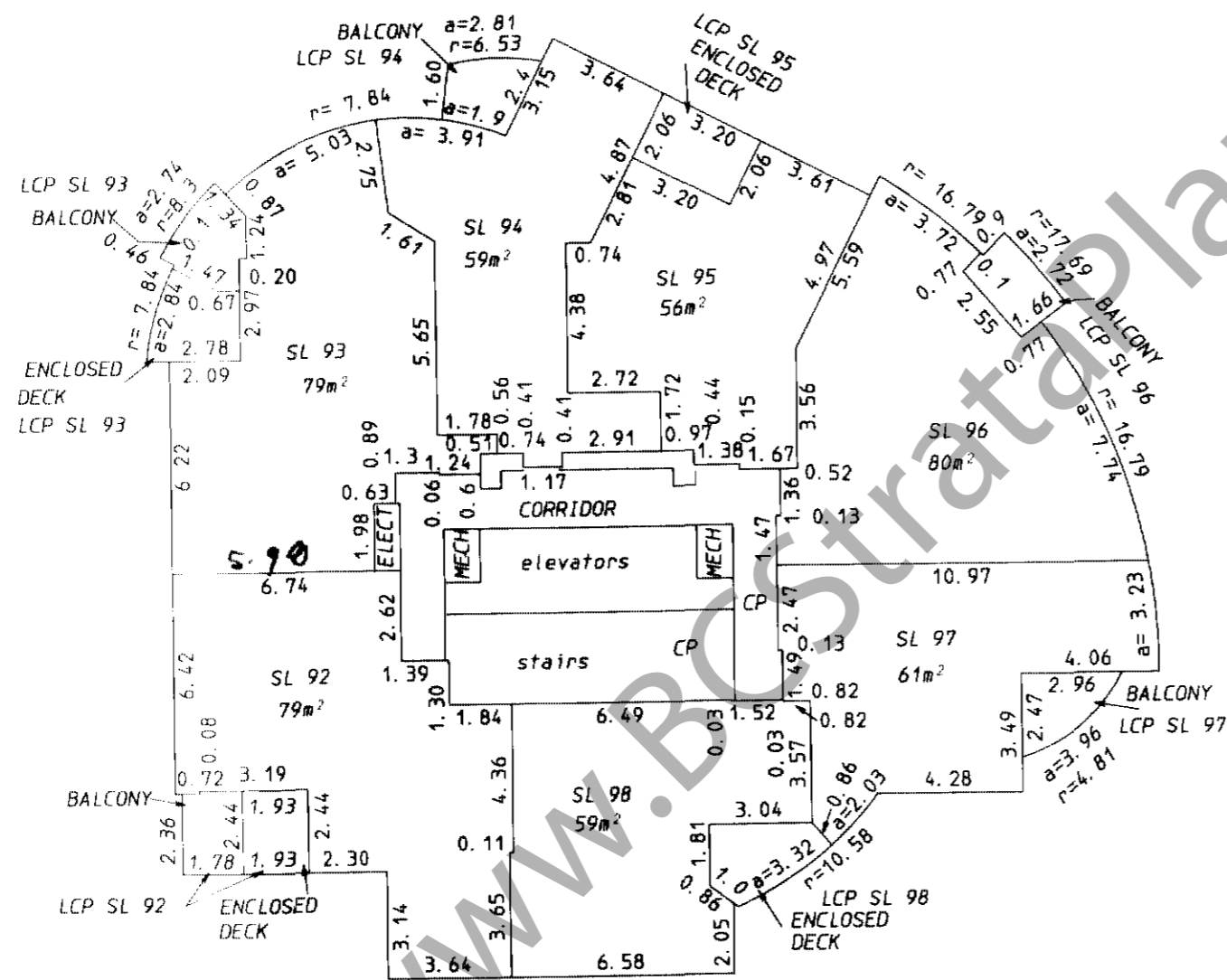

15th FLOOR

Caffo Land Surveying Ltd.

B. C. Land Surveyors
2027 East 50th Avenue
Vancouver, B. C. V5P 1V4
(fax) 604-327-2395

325-2696

File No: V-2076S

ORIGINAL

DATED 02/17/05 P.C. B. C. L. S.

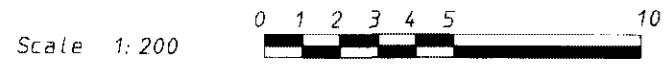

FLOOR PLAN

STRATA PLAN BCS 1180

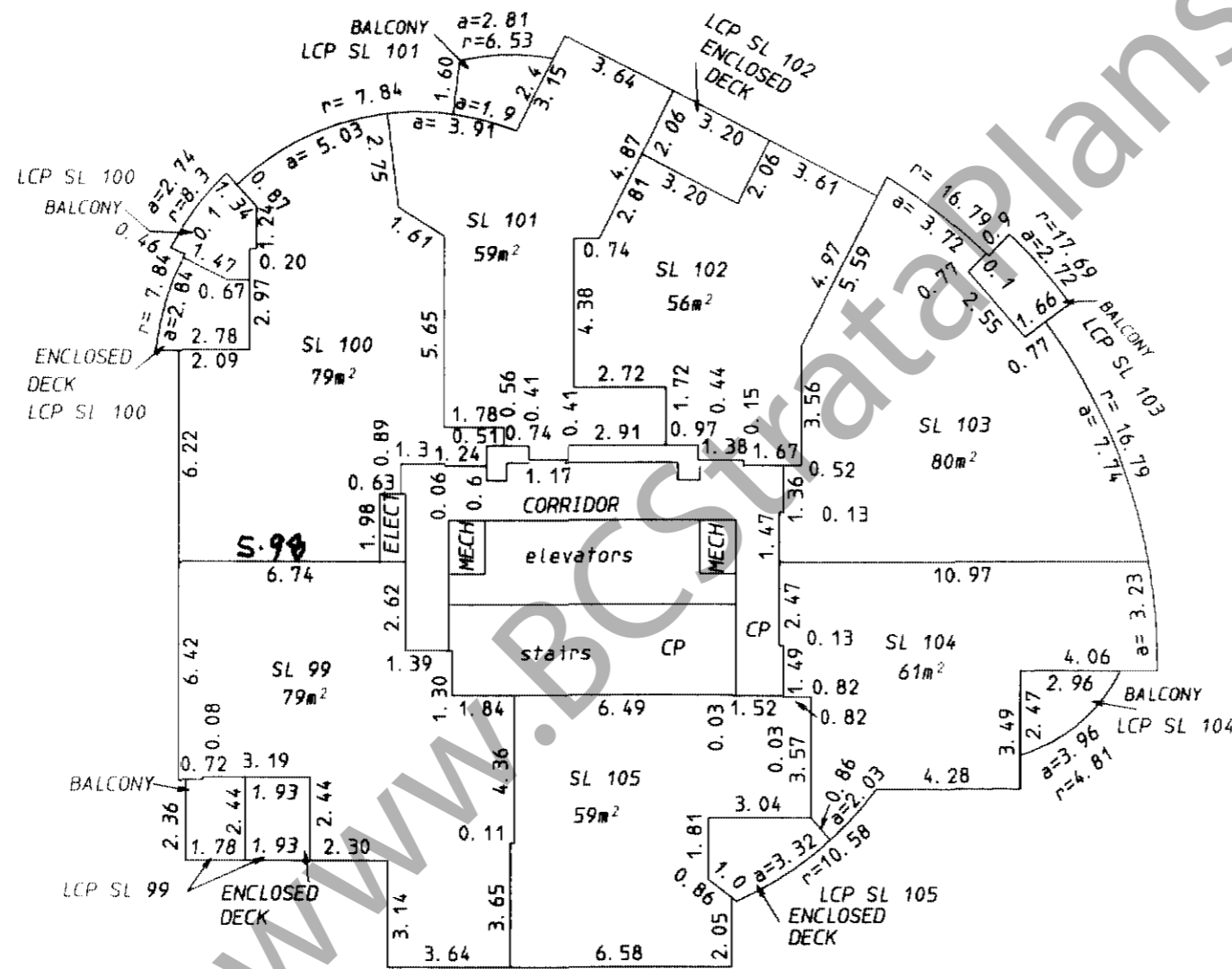

16th FLOOR

Caffo Land Surveying Ltd.

B. C. Land Surveyors
2027 East 50th Avenue
Vancouver, B. C. V5P 1V4
(fax) 604-327-2395

325-2696

File No: V-2076S

ORIGINAL

DATED 02/17/05 P.C. B. C. L. S.

Scale 1:200

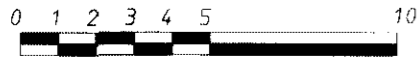

STRATA PLAN BCS 1180

FLOOR PLAN

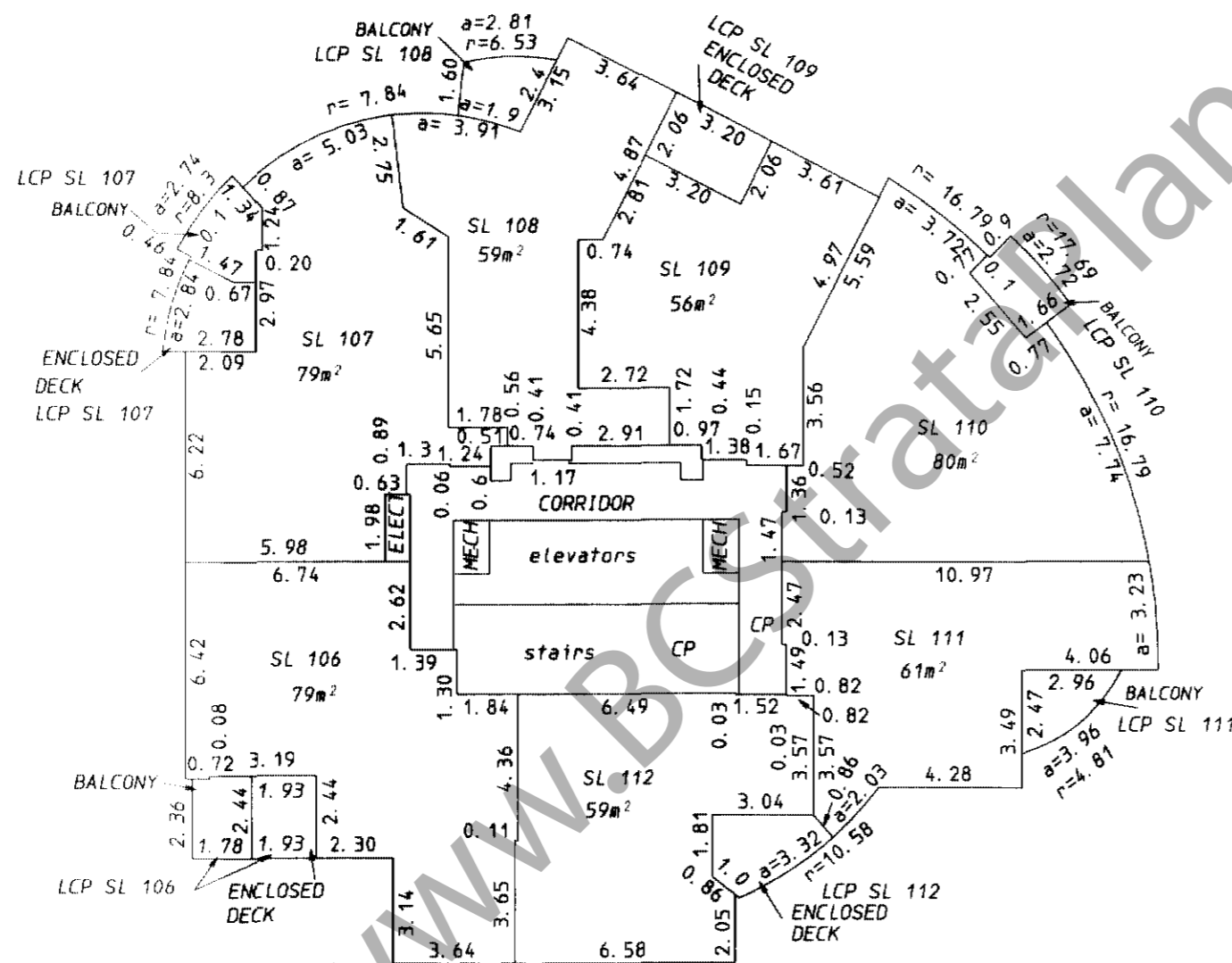

17th FLOOR

Caffo Land Surveying Ltd.

B. C. Land Surveyors
2027 East 50th Avenue
Vancouver, B. C. V5P 1V4
(fax) 604-327-2395

325-2696

File No: V-2076S

ORIGINAL

DATED

02/17/05 P.C.

B. C. L. S.

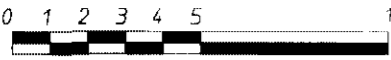
Scale 1:200 

Sheet 25 of 31 Sheets

FLOOR PLAN

STRATA PLAN BCS 1180

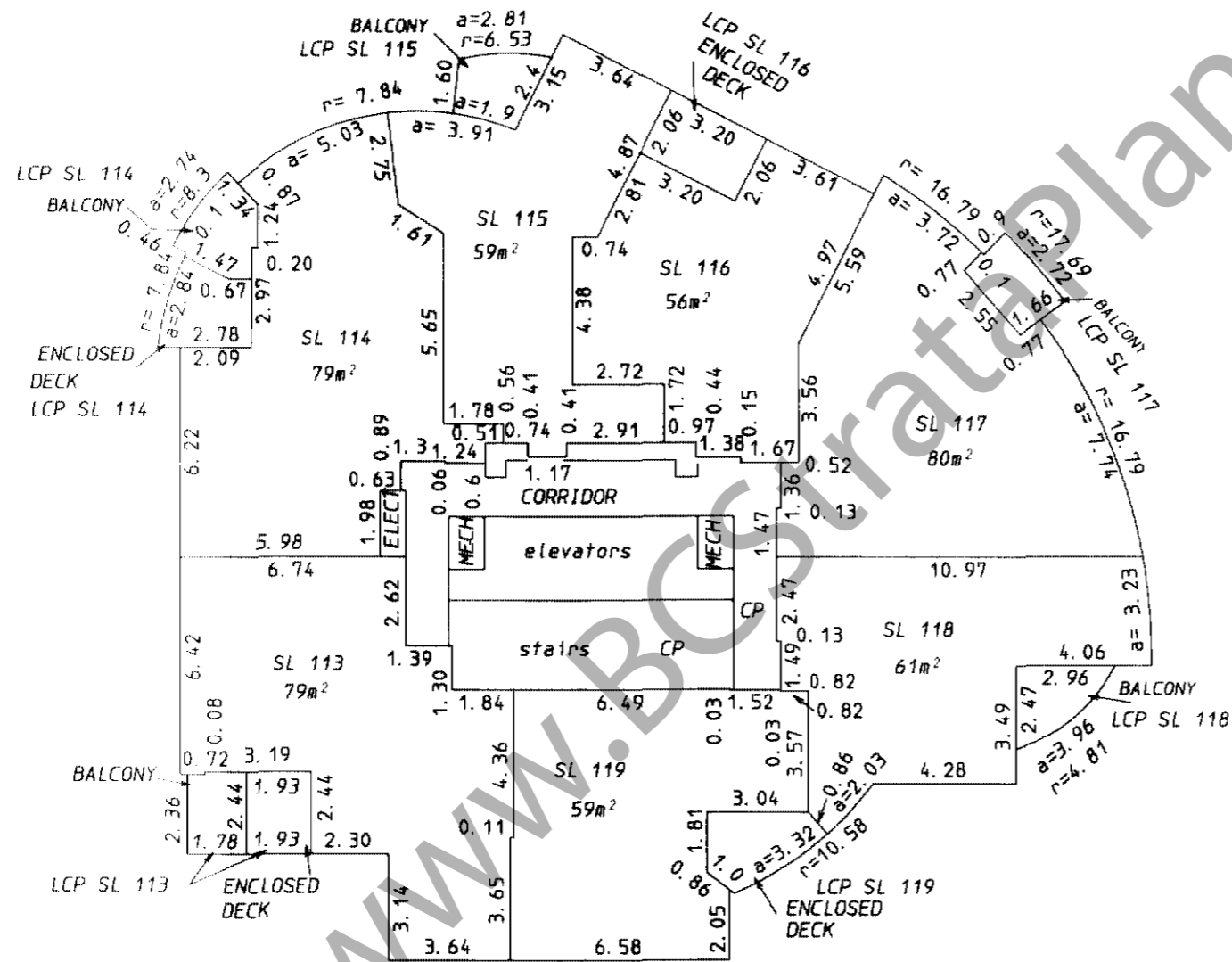

WWW.StrataPlans.com

Caffo Land Surveying Ltd.

B. C. Land Surveyors
2027 East 50th Avenue
Vancouver, B. C. V5P 1V4
(fax) 604-327-2395

325-2696

18th FLOOR

File No. V-20765

ORIGINAL

DATED 02/17/05 R.C. B. C. L. S.

Scale 1:200

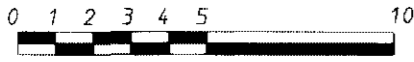

STRATA PLAN BCS 1180

FLOOR PLAN

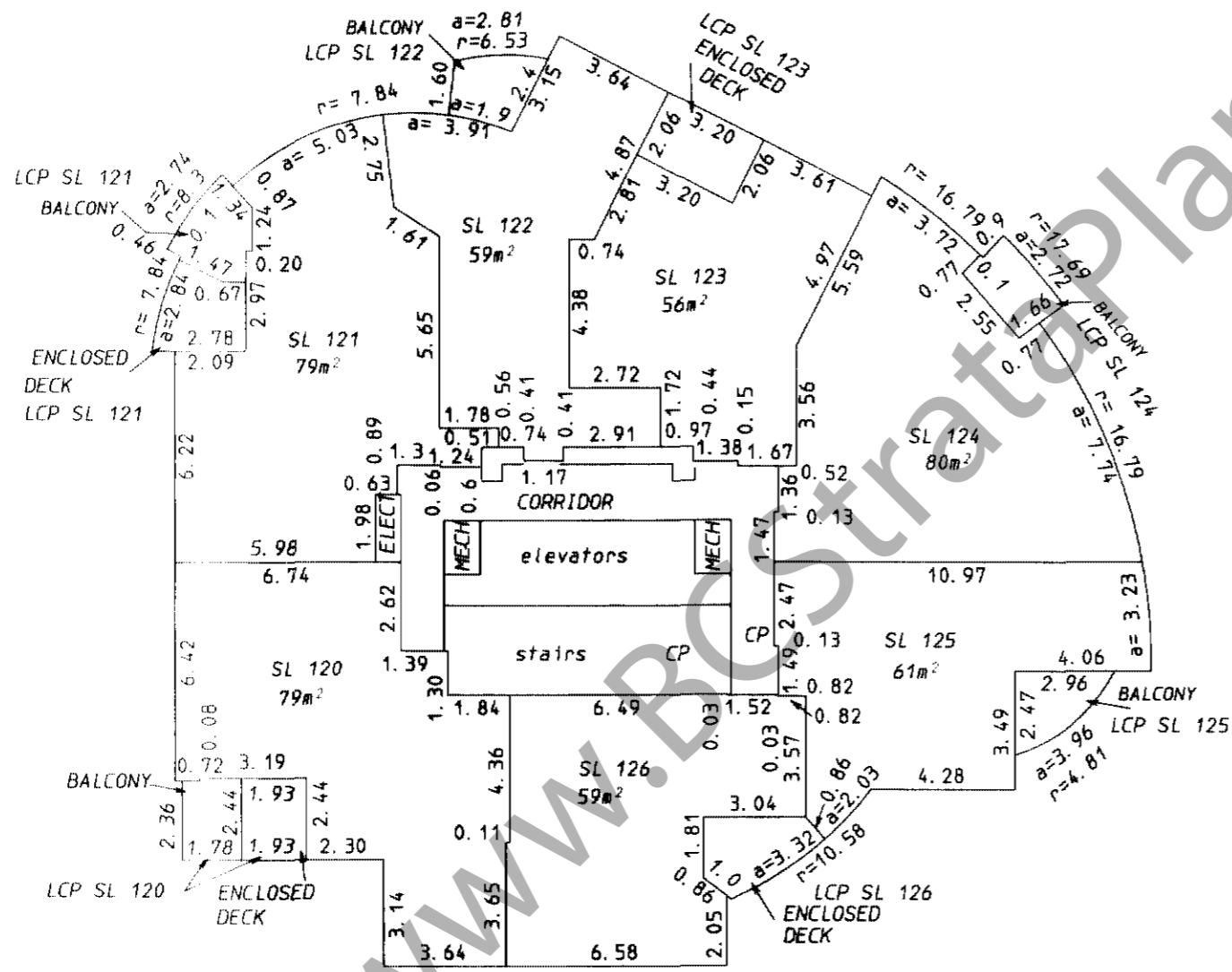
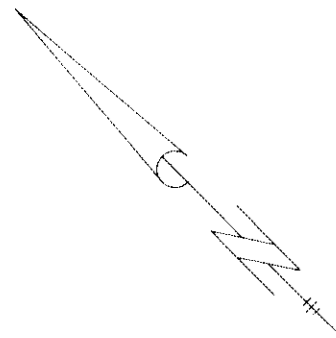

19th FLOOR

Caffo Land Surveying Ltd.

B. C. Land Surveyors
2027 East 50th Avenue
Vancouver, B. C. V5P 1V4
(fax) 604-327-2395

325-2696

File No: V-2076S

ORIGINAL

DATED

02/17/05 *P.C.*

B. C. L. S.

Scale 1:200

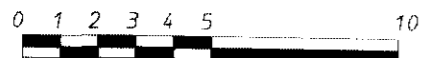

Sheet 27 of 31 Sheets

FLOOR PLAN

STRATA PLAN BCS 1180

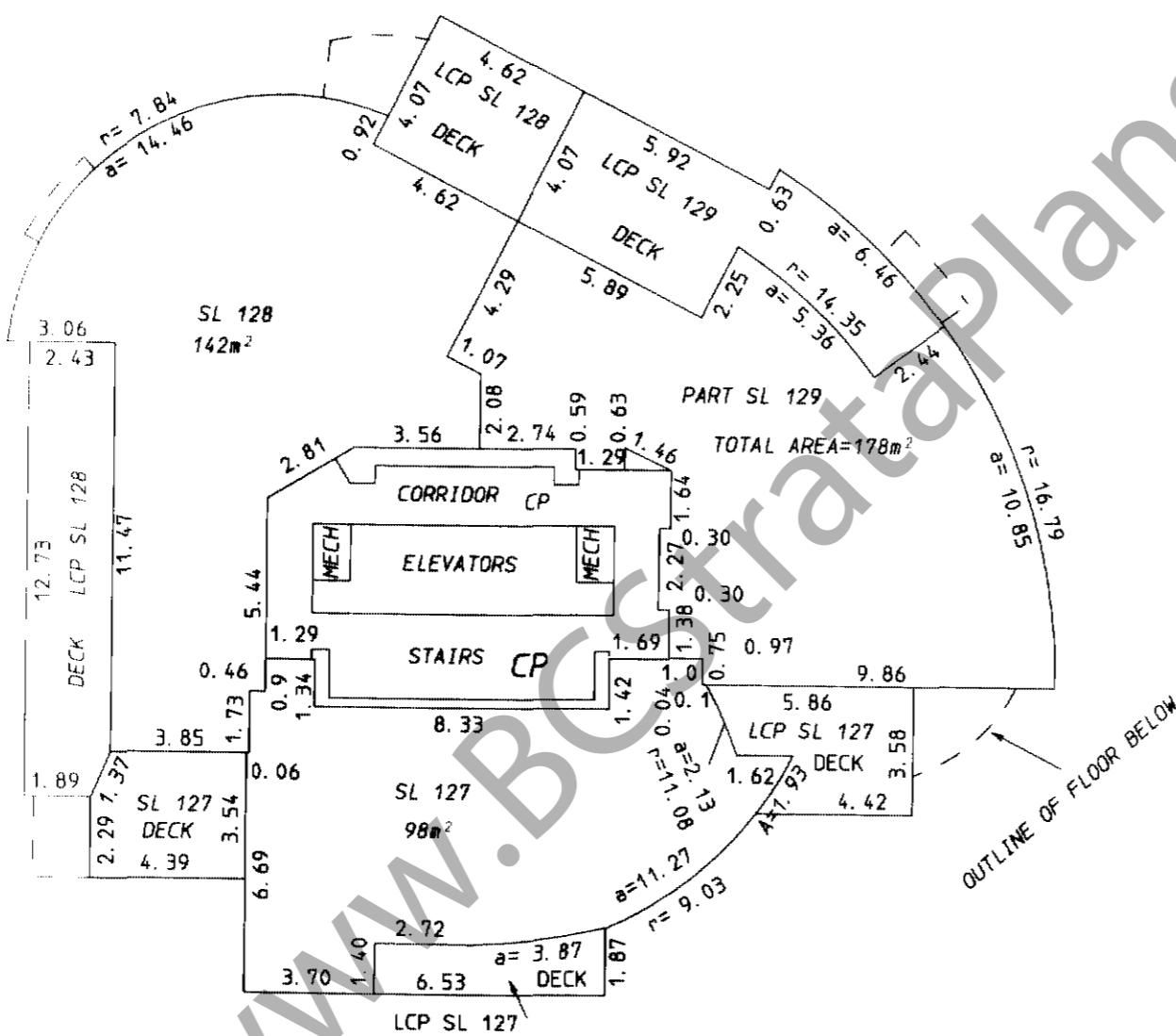

20TH FLOOR

WWW.StrataPlans.com

Caffo Land Surveying Ltd.

B. C. Land Surveyors
2027 East 50th Avenue
Vancouver, B. C. V5P 1V4
(fax) 604-327-2395

325-2696

File No: V-2076S

ORIGINAL

DATED 02/17/05 P.C.

B. C. L. S.

STRATA PLAN BCS 1180

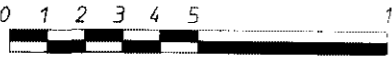
Scale 1:200 

FLOOR PLAN

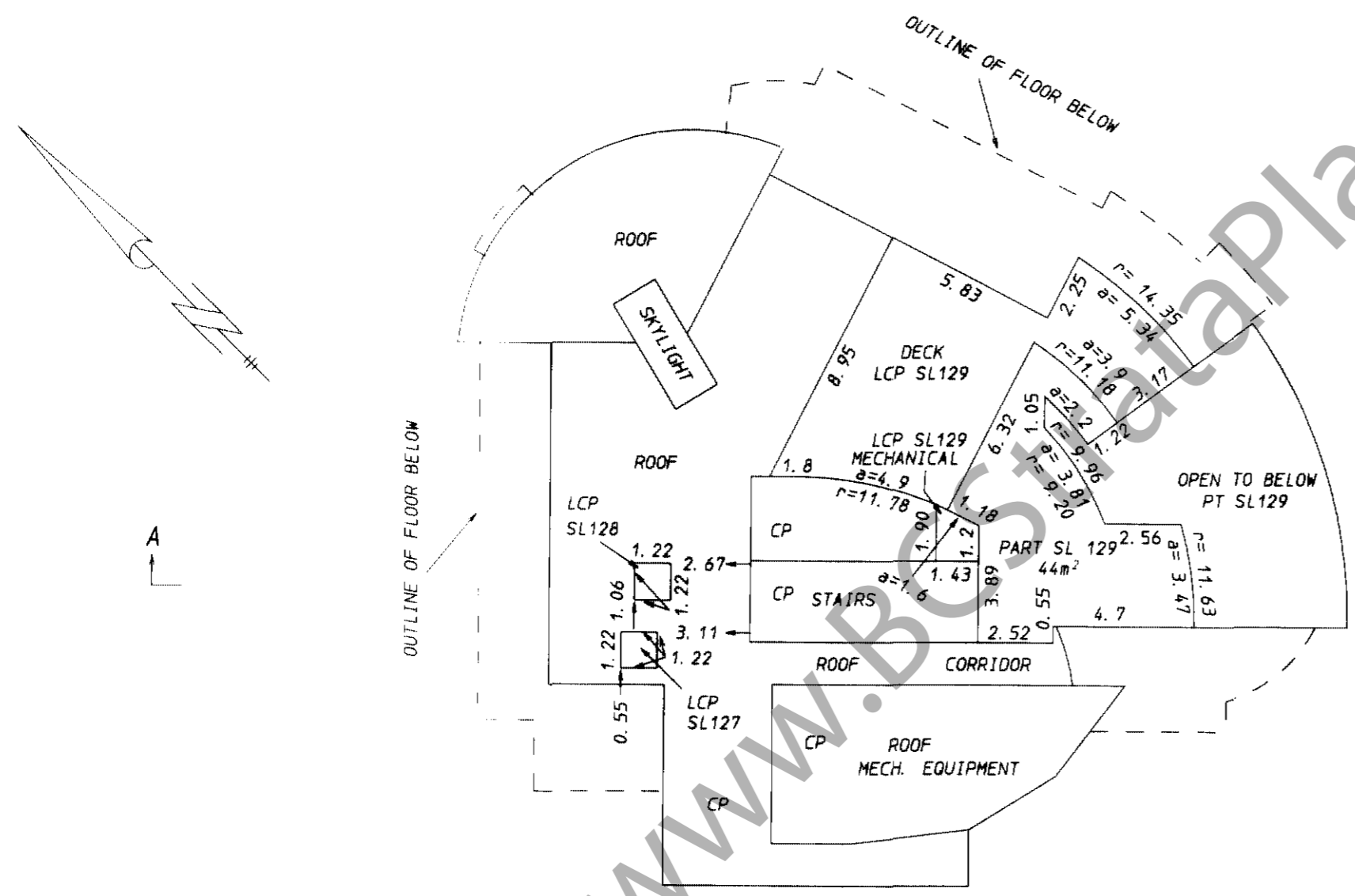

21ST FLOOR

Caffo Land Surveying Ltd.
 B. C. Land Surveyors
 2027 East 50th Avenue
 Vancouver, B. C. V5P 1V4
 (fax) 604-327-2395
325-2696

File No: V-20755

ORIGINAL

DATED 02/17/05 P.C. B. C. L. S.

Scale 1:200



Sheet 29 of 31 Sheets

FLOOR PLAN

STRATA PLAN BCS 1180

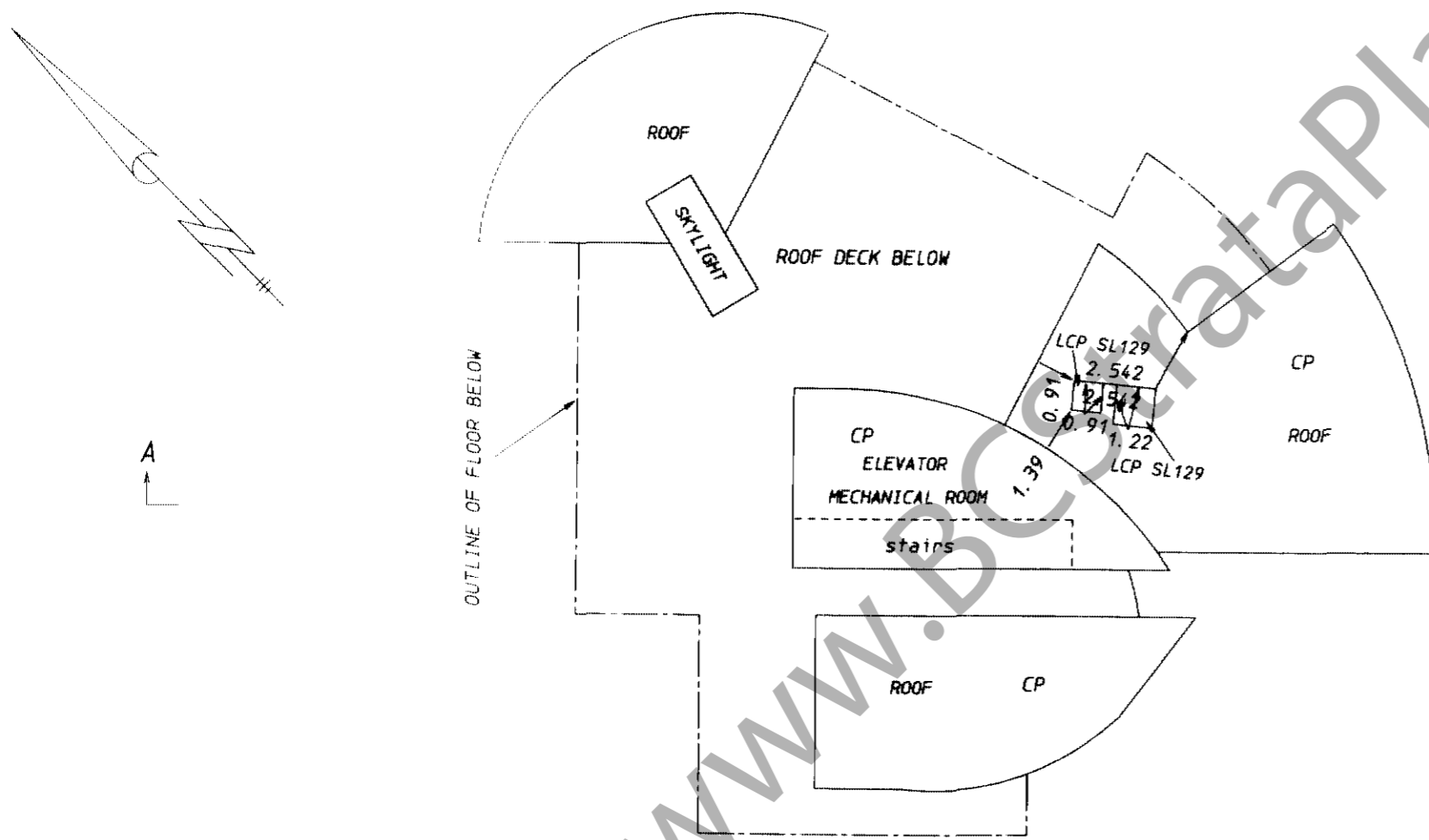

22nd FLOOR

Caffo Land Surveying Ltd.

B. C. Land Surveyors
2027 East 50th Avenue
Vancouver, B. C. V5P 1V4
(fax) 604-327-2395

325-2696

File No. V-2076S

ORIGINAL

DATED

02/17/05 H.C.

B. C. L. S.

Scale 1:200



Sheet 30 of 31 Sheets

STRATA PLAN BCS 1180

CROSS SECTION PLAN

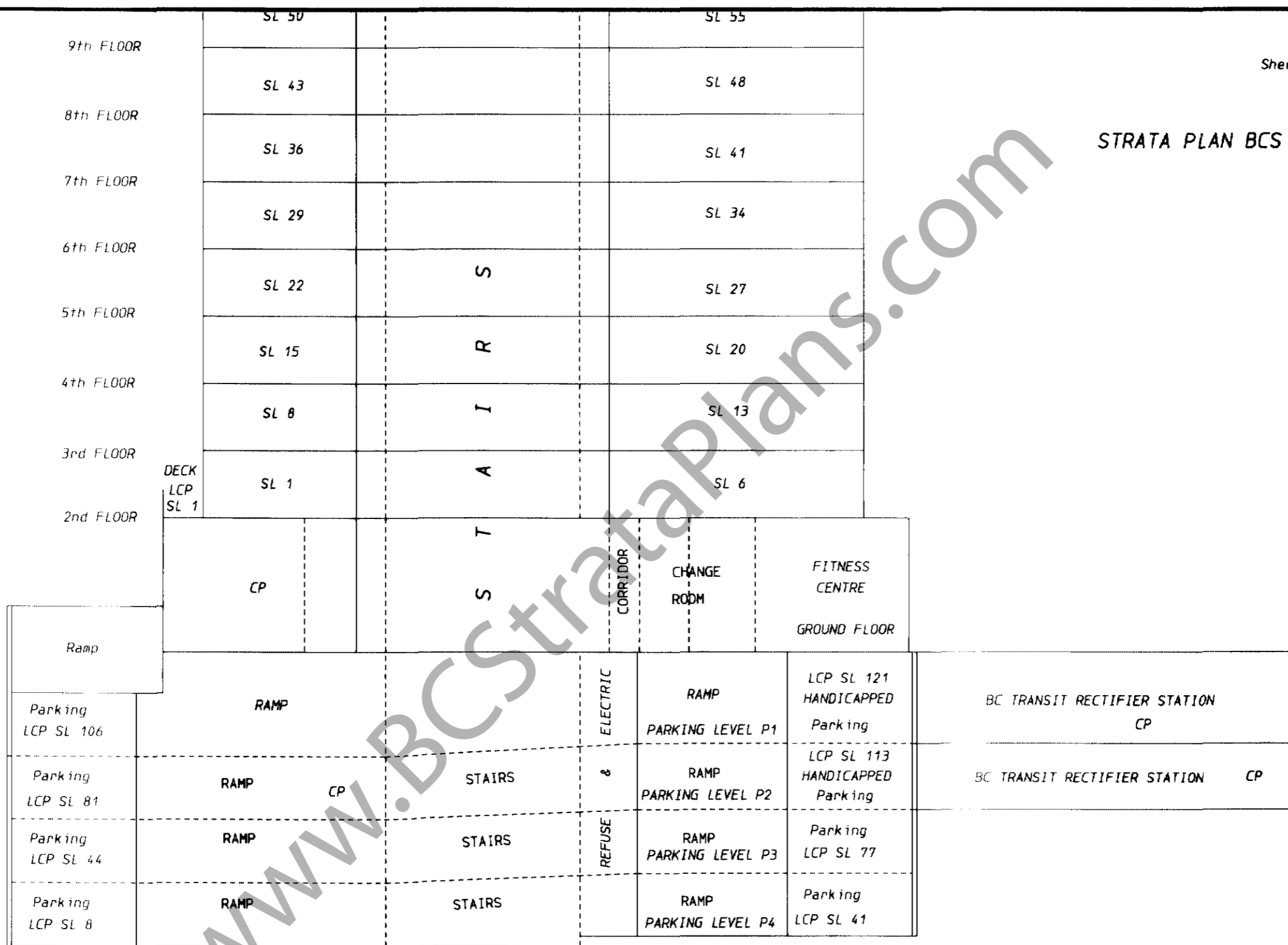

CROSS SECTION A-A

Caffo Land Surveying Ltd.
 B. C. Land Surveyors
 2027 East 50th Avenue
 Vancouver, B. C. V5P 1V4
 (fax) 604-327-2395
325-2696

File No. V-2076s

ORIGINAL

DATED 02/17/05 P.C. B. C. L. S.

Scale 1:200

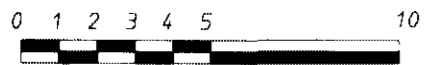

CROSS SECTION PLAN

CROSS SECTION A-A

STRATA PLAN BCS 1180

22nd FLOOR		ELEVATOR MECH. ROOM CP	ROOF
21st FLOOR	DECK LCP SL128	ROOF	PART SL 129
20th FLOOR	SL 128		PART SL 129
19th FLOOR	SL 120		SL 125
18th FLOOR	SL 113		SL 118
17th FLOOR	SL 106		SL 111
16th FLOOR	SL 99	R	SL 104
15th FLOOR	SL 92	D	SL 97
14th FLOOR	SL 85	R	SL 90
13th FLOOR	SL 78	R	SL 83
12th FLOOR	SL 71	CP	SL 76
11th FLOOR	SL 64		SL 69
10th FLOOR	SL 57	CP	SL 62
9th FLOOR	SL 50		SL 55
8th FLOOR	SL 43		SL 48
7th FLOOR	SL 36		SL 41
	SL 29		SL 34

Caffo Land Surveying Ltd.

B. C. Land Surveyors
 2027 East 50th Avenue
 Vancouver, B.C. V5P 1V4
 (fax) 604-327-2395

325-2696

File No. V-2076s

DATED 02/17/05 P.C. B.C.L.S.
 ORIGINAL