

STRATA PLAN OF PARCEL 1
BLOCK 85 DISTRICT LOT 541 GROUP 1
NEW WESTMINSTER DISTRICT PLAN LMP51512

STRATA PLAN BCS 552

CITY OF VANCOUVER
B.C.G.S. 92G.025

DEPOSITED AND REGISTERED IN THE LAND
TITLE OFFICE AT NEW WESTMINSTER B.C.
OCTOBER 15 2003



SCALE 1 : 500 DISTANCES ARE METRIC

B. B. [Signature]

REGISTRAR

BU 422898 - BU 423082

INTEGRATED SURVEY AREA NO.31 (VANCOUVER)
NAD83(CSRS)

THIS PLAN SHOWS HORIZONTAL GROUND-LEVEL DISTANCES
EXCEPT WHERE OTHERWISE NOTED. TO COMPUTE GRID DISTANCES,
MULTIPLY GROUND-LEVEL DISTANCES BY COMBINED FACTOR 0.9996008



LEGEND

GRID BEARINGS ARE DERIVED FROM OBSERVATIONS BETWEEN
CONTROL MONUMENTS V2161 AND V2168

- ⊙ DENOTES CONTROL MONUMENT
- DENOTES IRON POST FOUND
- S.L. DENOTES STRATA LOT
- PT. DENOTES PART
- m2 DENOTES SQUARE METRES
- LCP DENOTES LIMITED COMMON PROPERTY
- ⊙ DENOTES COMMON PROPERTY
- ⓔ DENOTES ELEVATOR BEING COMMON PROPERTY
- ⓓ DENOTES DUCT BEING COMMON PROPERTY
- Ⓜ DENOTES MECHANICAL BEING COMMON PROPERTY
- Ⓢ DENOTES STAIR BEING COMMON PROPERTY
- ⓑ DENOTES BALCONY BEING LIMITED COMMON PROPERTY FOR EXCLUSIVE USE OF ADJOINING STRATA LOT
- Ⓟ DENOTES PATIO BEING LIMITED COMMON PROPERTY FOR EXCLUSIVE USE OF ADJOINING STRATA LOT
- Ⓟ-1 DENOTES PATIO BEING LIMITED COMMON PROPERTY FOR EXCLUSIVE USE OF STRATA LOT 1 (TYPICAL)
- Ⓡⓓ DENOTES ROOF DECK BEING LIMITED COMMON PROPERTY FOR EXCLUSIVE USE OF ADJOINING STRATA LOT
- Ⓡⓓ-2 DENOTES ROOF DECK BEING LIMITED COMMON PROPERTY FOR EXCLUSIVE USE OF STRATA LOT 2 (TYPICAL)

CIVIC ADDRESS:

1010 - RICHARDS STREET
VANCOUVER, B.C.

LEVEL 13 HAS BEEN ELIMINATED FROM CONSECUTIVE FLOOR NUMBERING

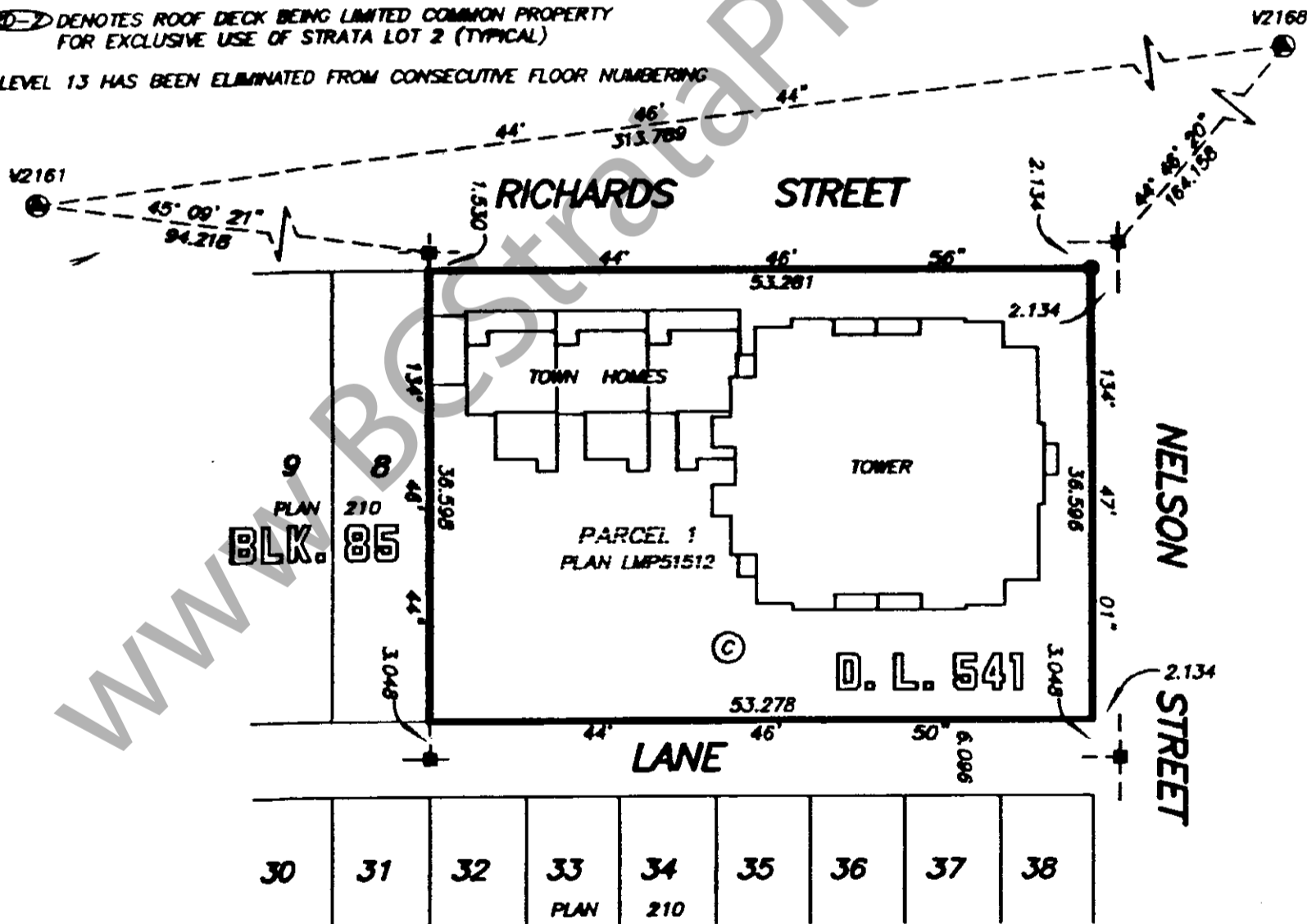

I, GARY SUNDVICK, A BRITISH COLUMBIA LAND SURVEYOR, OF LANGLEY, BRITISH COLUMBIA, CERTIFY THAT I WAS PRESENT AT AND PERSONALLY SUPERINTENDED THE SURVEY REPRESENTED BY THIS PLAN, AND THAT THE SURVEY AND PLAN ARE CORRECT. THE SURVEY WAS COMPLETED ON THE 7th DAY OF OCTOBER, 2003. THE PLAN WAS COMPLETED AND CHECKED, AND THE CHECKLIST FILED UNDER ECP/8696, ON THE 7th DAY OF OCTOBER, 2003.

I, GARY SUNDVICK, A BRITISH COLUMBIA LAND SURVEYOR CERTIFY THAT THE BUILDING SHOWN ON THIS STRATA PLAN IS WITHIN THE EXTERNAL BOUNDARIES OF THE LAND THAT IS THE SUBJECT OF THE STRATA PLAN. DATE: 7th DAY OF OCTOBER, 2003.

[Signature] B.C.L.S.

[Signature] B.C.L.S.

DYCK & ASSOCIATES
PROFESSIONAL LAND SURVEYORS
#4 - 19089 94th AVENUE
SURREY, B.C. V4N 3S4
TEL: 513-9611 FAX: 513-2202
FILE : 2616
DWG : 2616-S10

THIS PLAN LIES WITHIN THE GREATER VANCOUVER REGIONAL DISTRICT

ORIGINAL

FILED VABCS552 2005-12-01-13.28.43.118806

STRATA PROPERTY ACT

OWNER:

POLYGON GALLERY TOWER LTD.
(INC. No. 610424)

Name _____

Authorized Signatory **RALF SCHMIDTKE**

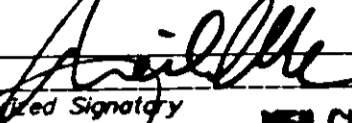
Name _____

Authorized Signatory **NEIL CHRYSAL**

WITNESS AS TO BOTH SIGNATURES
Name **Jessie Irving**

900 1383 W. BROADWAY
ADDRESS

VANCOUVER, B.C.

DEVELOPMENT COORDINATOR
OCCUPATION OF WITNESS

MORTGAGEES:

~~HSBC BANK CANADA BANK OF NOVA SCOTIA~~

Name **MICHAEL DOLAN**
Authorized Signatory

Name _____
Authorized Signatory

WITNESS AS TO BOTH SIGNATURES
Name **Penny Allen**

3400 - 650 W. GEORGIA VANCOUVER
ADDRESS

V6B 4N7

B. WAKER
OCCUPATION OF WITNESS

L GARY SUNDVICK, A BRITISH COLUMBIA LAND SURVEYOR CERTIFY THAT THE BUILDING INCLUDED IN THIS STRATA PLAN HAS NOT, AS OF OCTOBER 7th, 2003 BEEN PREVIOUSLY OCCUPIED.

B.C.L.S.

HSBC CAPITAL (CANADA) INC.

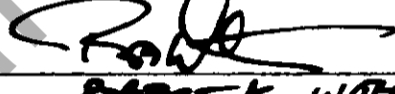
Name **ROBERT K. WILTON**
Authorized Signatory **DIRECTOR**

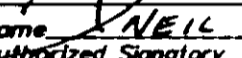
Name **NEIL JOHANSON**
Authorized Signatory **MANAGING DIRECTOR**

WITNESS AS TO BOTH SIGNATURES
Name **Manuela Armenta**

200-885 W. Georgia St.
ADDRESS

Vancouver, B.C. V6C 3G1

Credit officer
OCCUPATION OF WITNESS

HSBC BANK CANADA

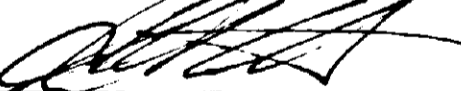
Name **GERALD A. STOLL**
Authorized Signatory

Name **ANDREW STILLER**
Authorized Signatory

WITNESS AS TO BOTH SIGNATURES
Name **Manuela Armenta**

200-885 W. Georgia St.
ADDRESS

Vancouver, B.C. V6C 3G1

Credit Officer
OCCUPATION OF WITNESS

OCTOBER 7, 2003
FILE: 2616-S10

ORIGINAL

FILED
VBCS552
S32034 2005-12-01-13.28.43.118806

BIUILDING LOCATION

STRATA PLAN BCS 552

0 5 10 15 20



SCALE 1 : 250 DISTANCES ARE METRIC



NELSON STREET

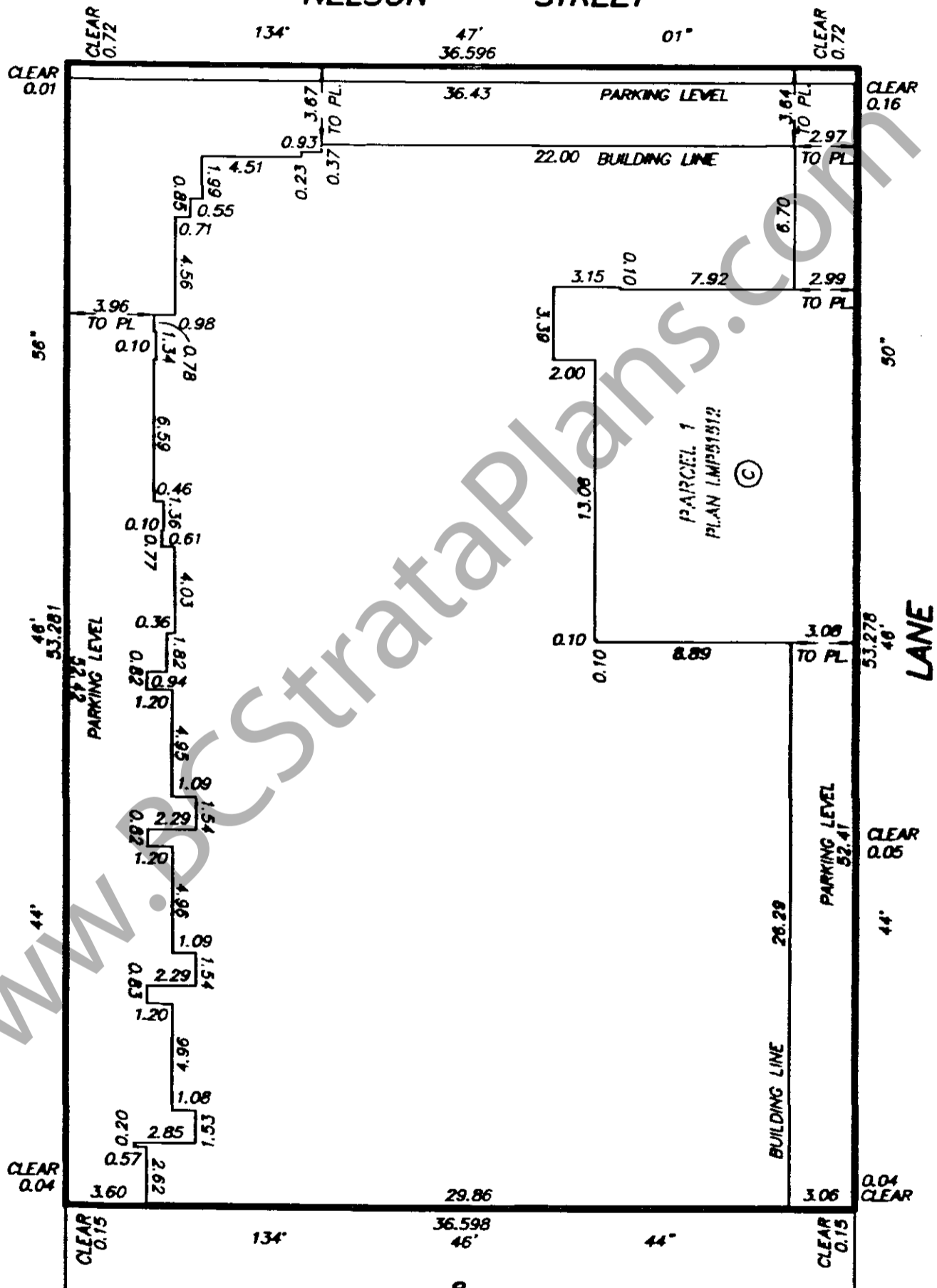

RICHARDS STREET

LANE

PARCEL 1
PLAN LMP51512
C

8

PLAN 210

OCTOBER 7, 2003
DWG : 2616-S11

ORIGINAL

FILED S32034 2005-12-01-13.28.43.118806 VABCS552

PARKING LEVEL P-3

STRATA PLAN BCS 552

0 5 10 15
SCALE 1:200 DISTANCES ARE METRIC

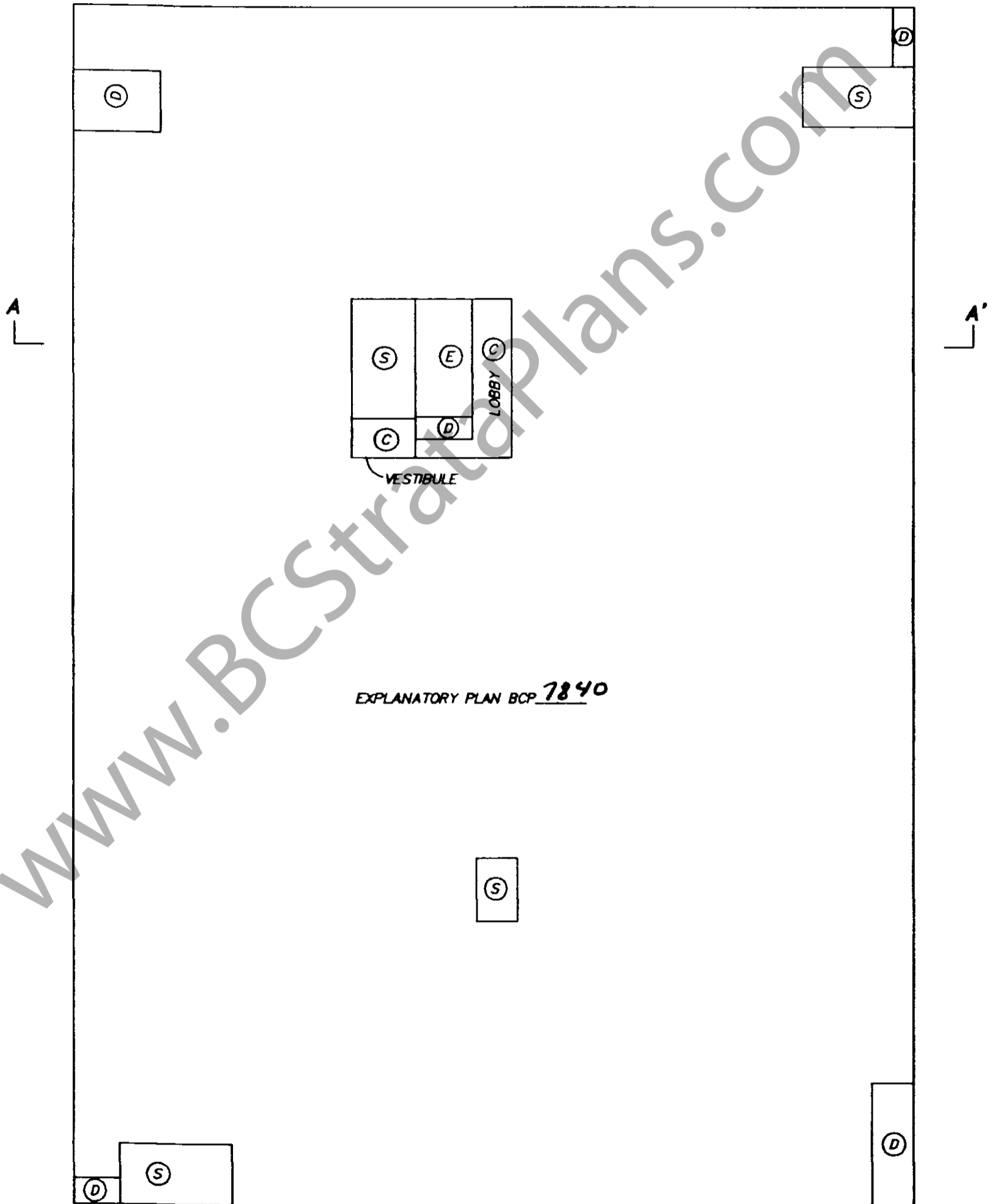

EXPLANATORY PLAN BCP 7840

OCTOBER 7, 2003
FILE: 2616-S13

ORIGINAL

FILED VABCS552 2005-12-01-13.28.43.118806

STRATA PLAN BCS 222

PARKING LEVEL P-2

SCALE 1:500 DISTANCES ARE METRIC

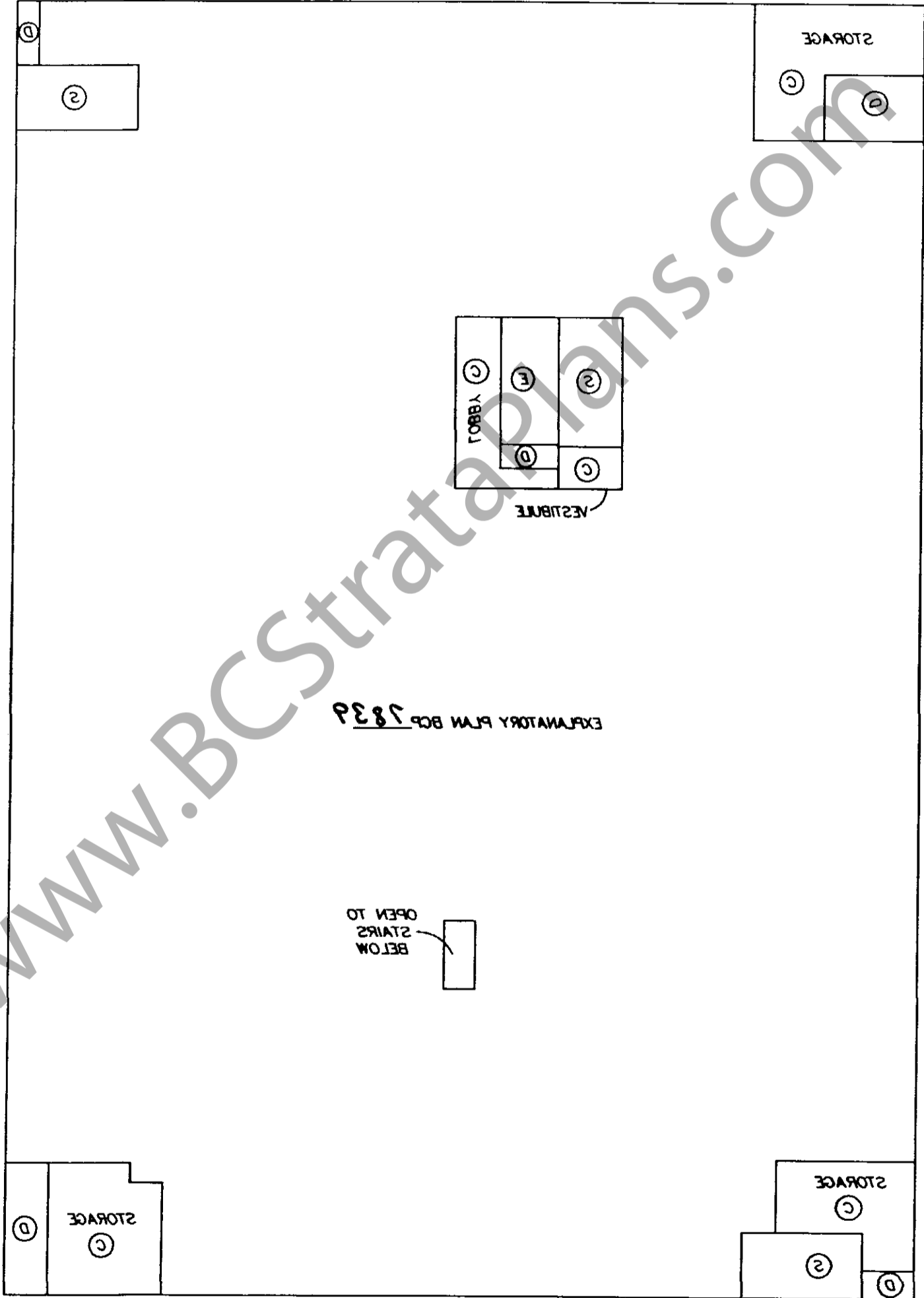

EXPLANATORY PLAN BCS 222

FILE: 2018-213 REV.1
OCTOBER 7, 2003

PARKING LEVEL P-1

STRATA PLAN BCS 552

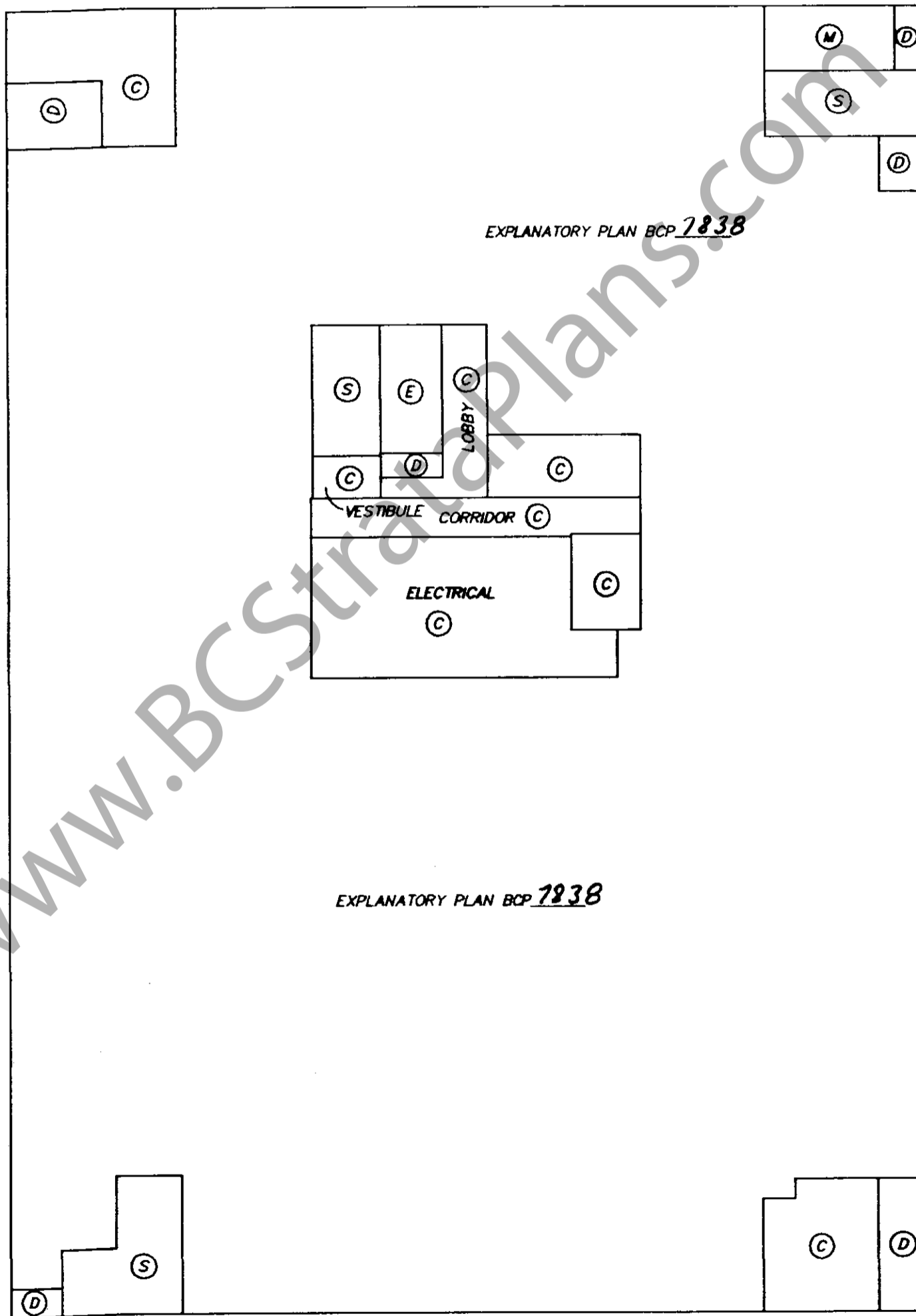

[Signature]
OCTOBER 7, 2003
FILE: 2616-S13

ORIGINAL

FILED VABCS552 2005-12-01-13.28.43.118806

LOWER GROUND LEVEL

STRATA PLAN BCS 552

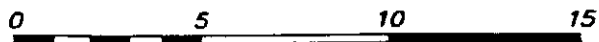

SCALE 1:200 DISTANCES ARE METRIC



PERIMETER OF FLOOR BELOW

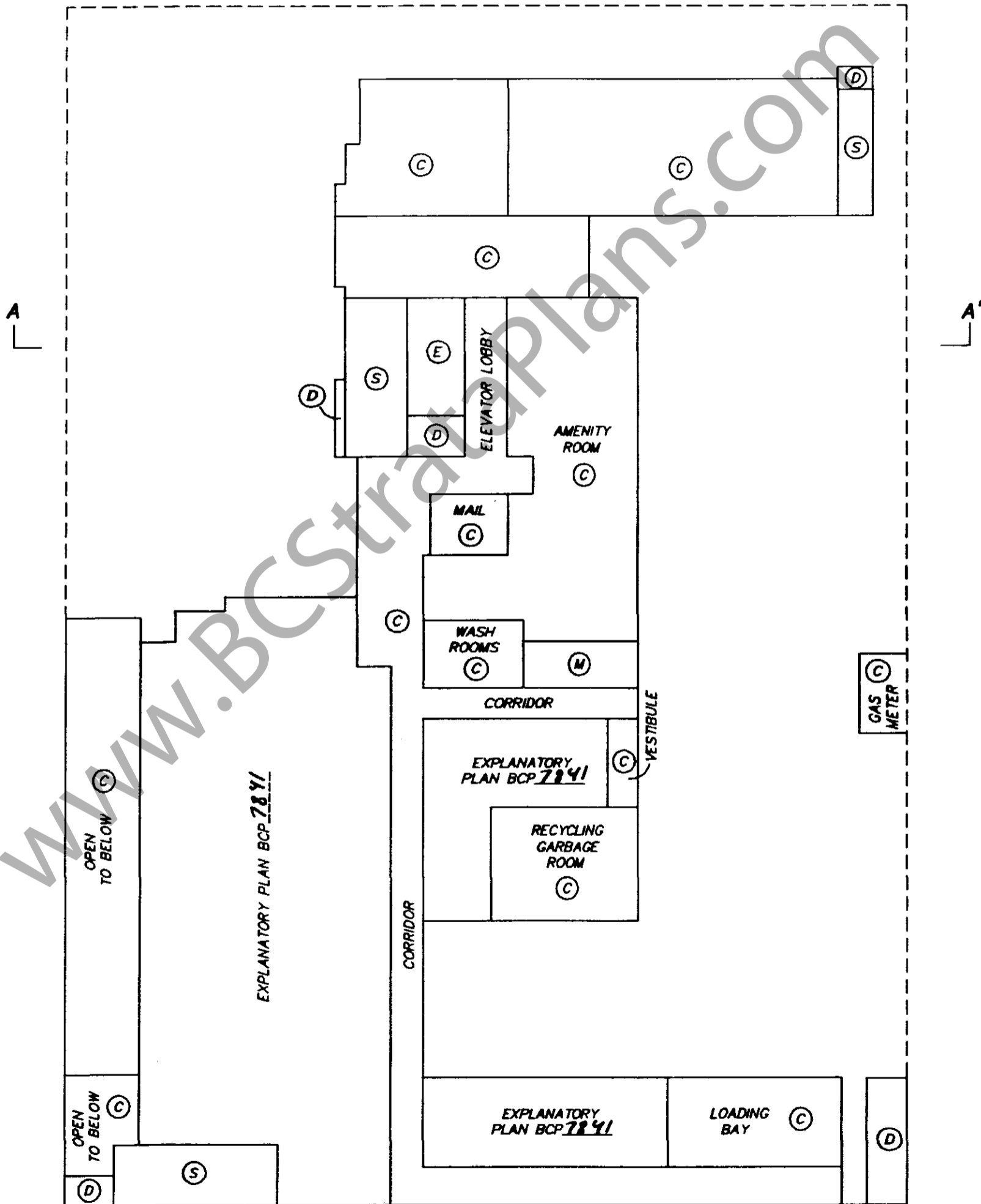

OCTOBER 7, 2003
FILE: 2616-S13 REV.1

FILED
VABCS552
S32034 2005-12-01-13.28.43.118806

UPPER GROUND LEVEL

STRATA PLAN BCS 552

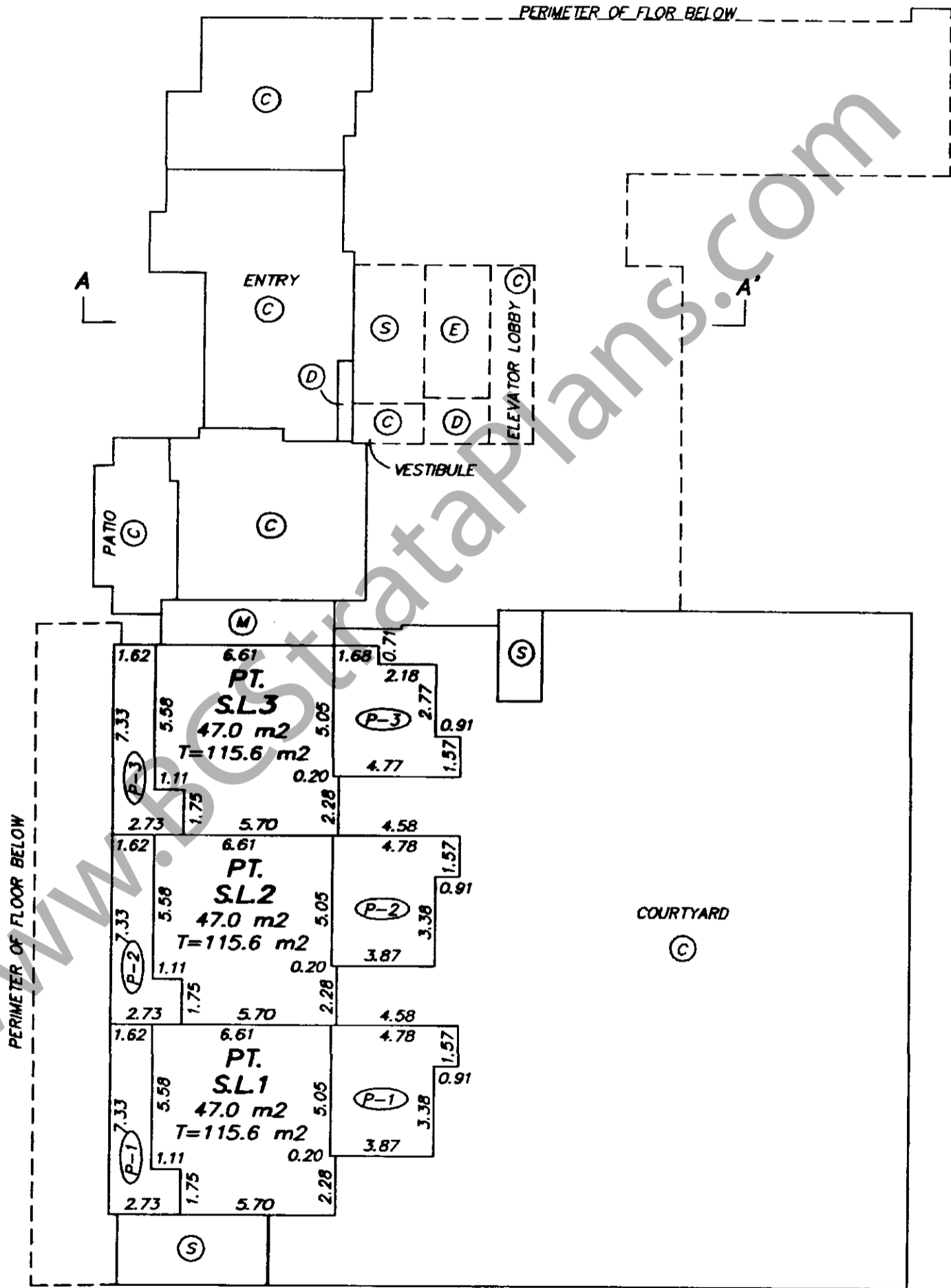

OCTOBER 7, 2003
FILE: 2616-S13

ORIGINAL

FILED VBCS552 2005-12-01-13.28.43.118806

LEVEL 2

STRATA PLAN BCS 552



SCALE 1:200 DISTANCES ARE METRIC

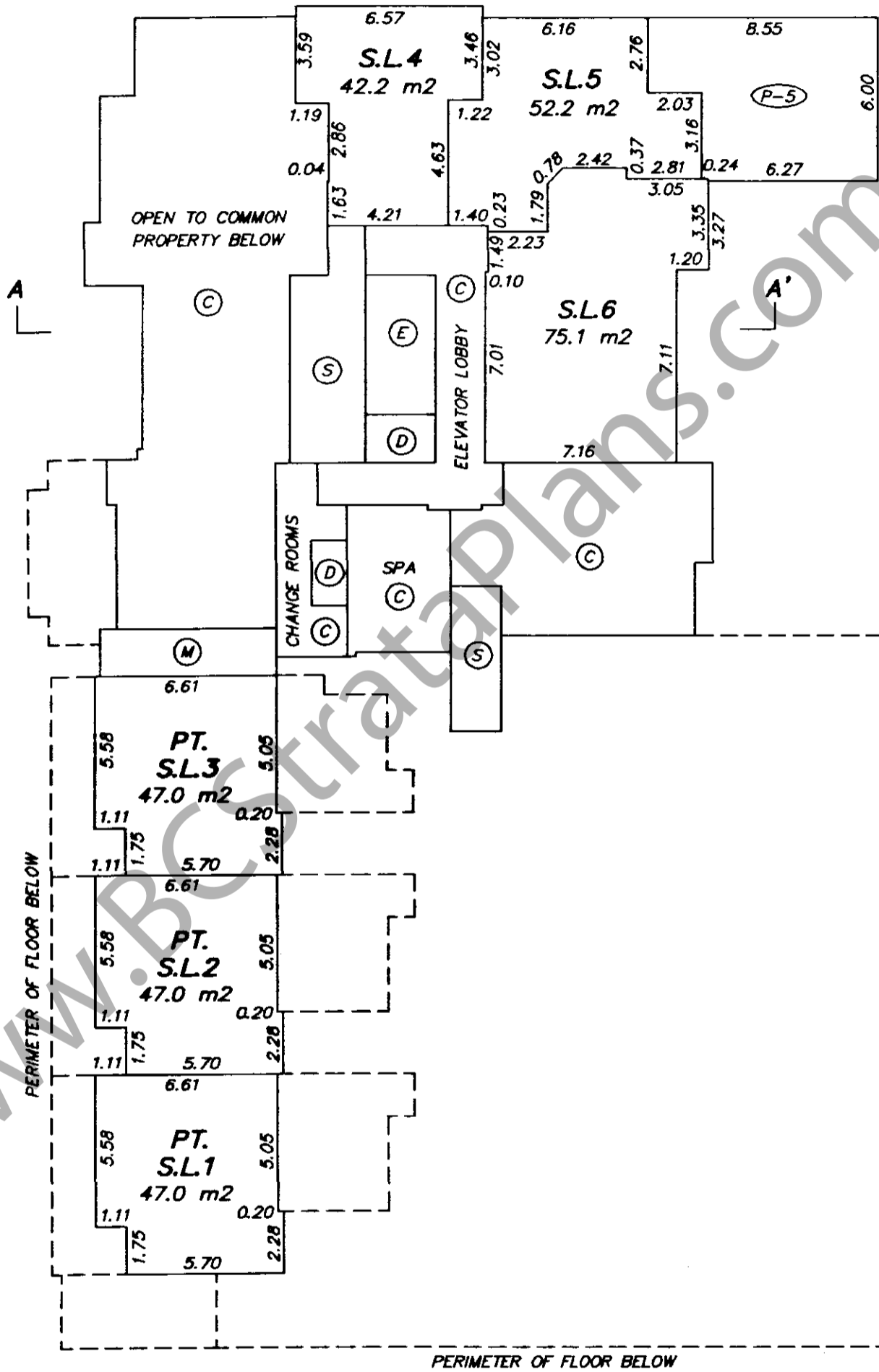

FILED S32034 2005-12-01-13.28.43.118806 VABCS552



 OCTOBER 7, 2003
 FILE: 2616-S13
 ORIGINAL

LEVEL 3

STRATA PLAN BCS 552

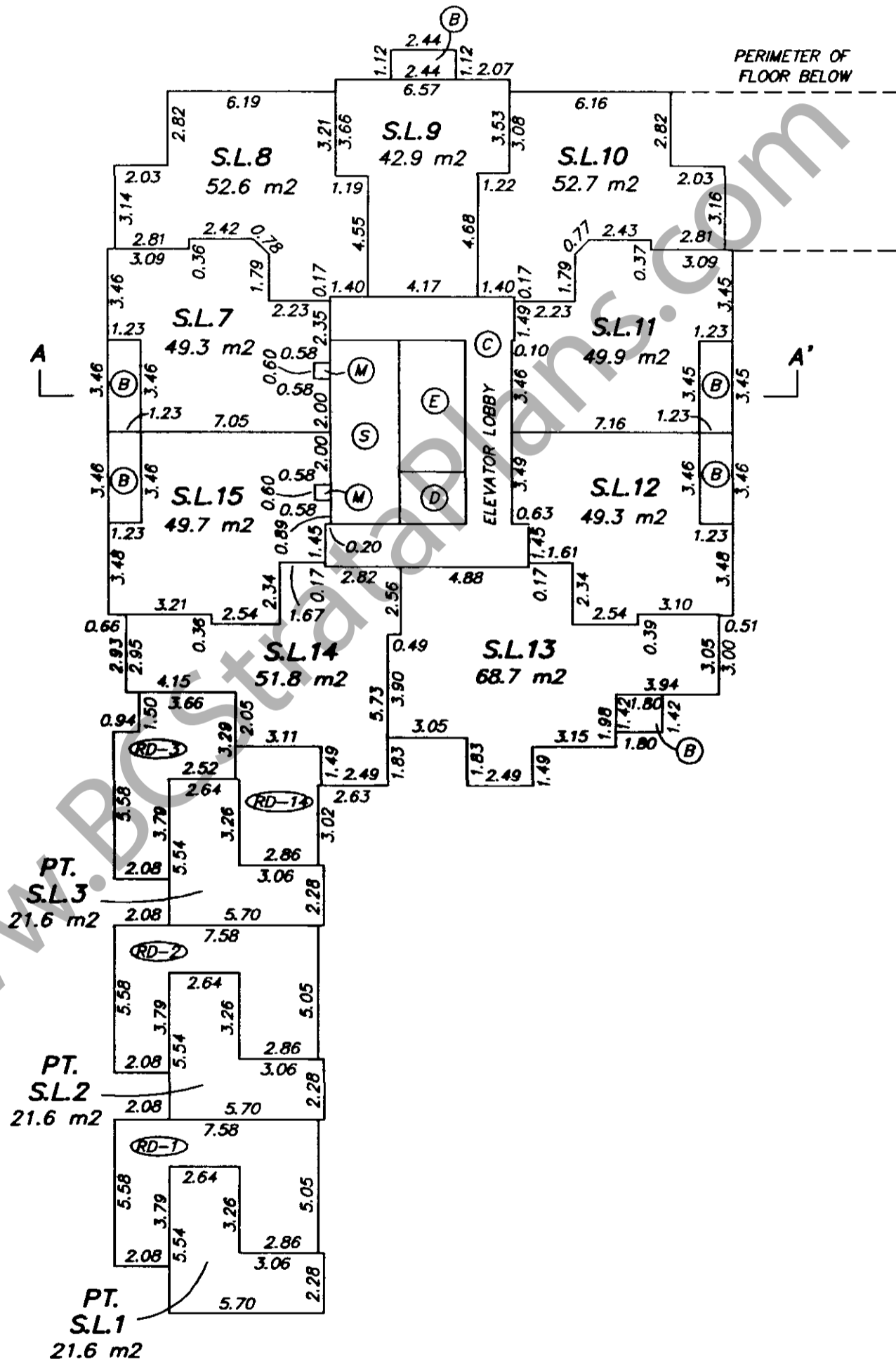

SCALE 1:200 DISTANCES ARE METRIC



OCTOBER 7, 2003
FILE: 2616-S13

ORIGINAL

FILED S32034 2005-12-01-13.28.43.118806 VABCS552

LEVEL 4

STRATA PLAN BCS 552

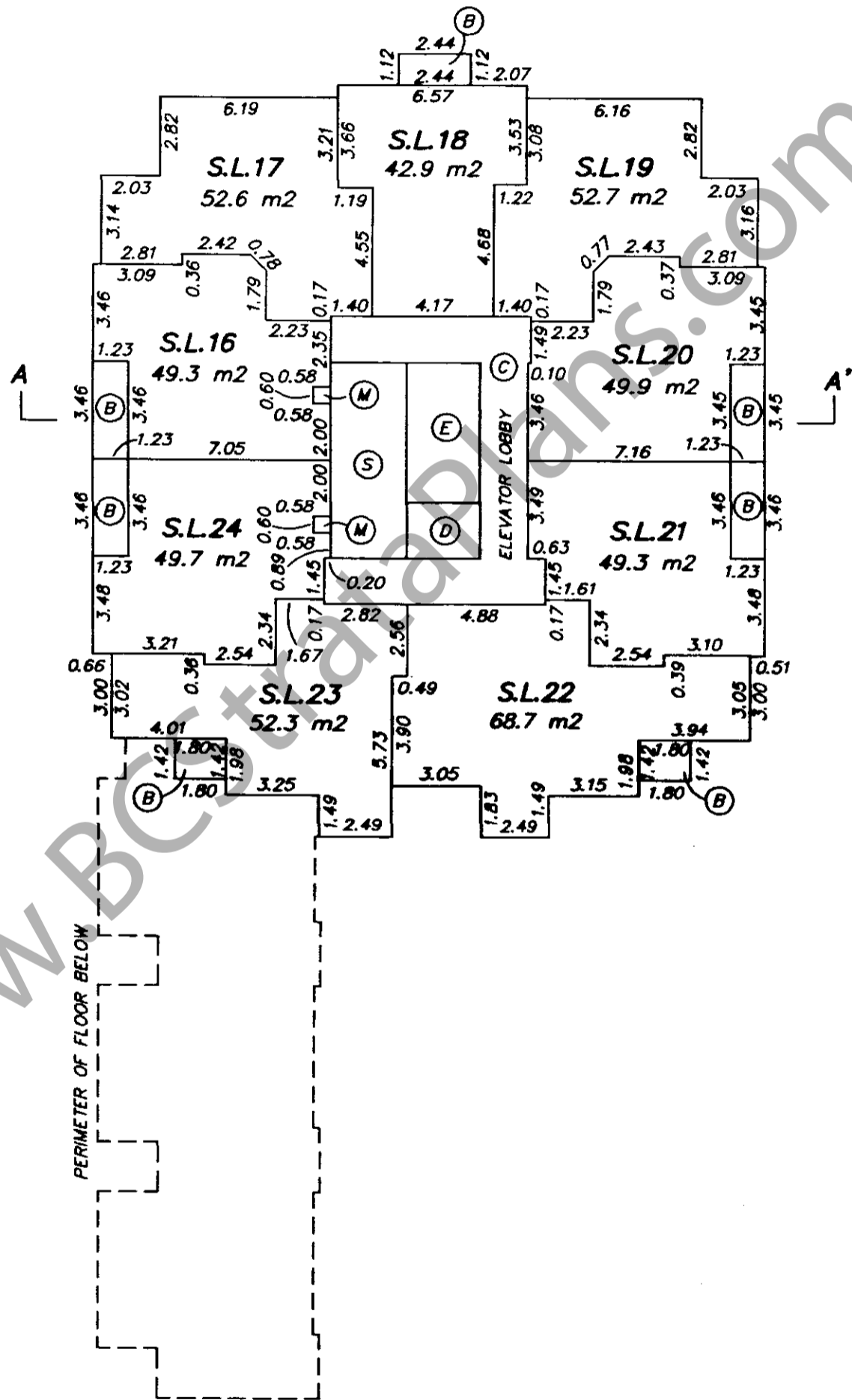

WWW.BCS552.COM

OCTOBER 7, 2003
FILE: 2616-S13

ORIGINAL

FILED S32034 2005-12-01-13.28.43.118806 VABCS552

FLOOR PLANS

STRATA PLAN BCS 552

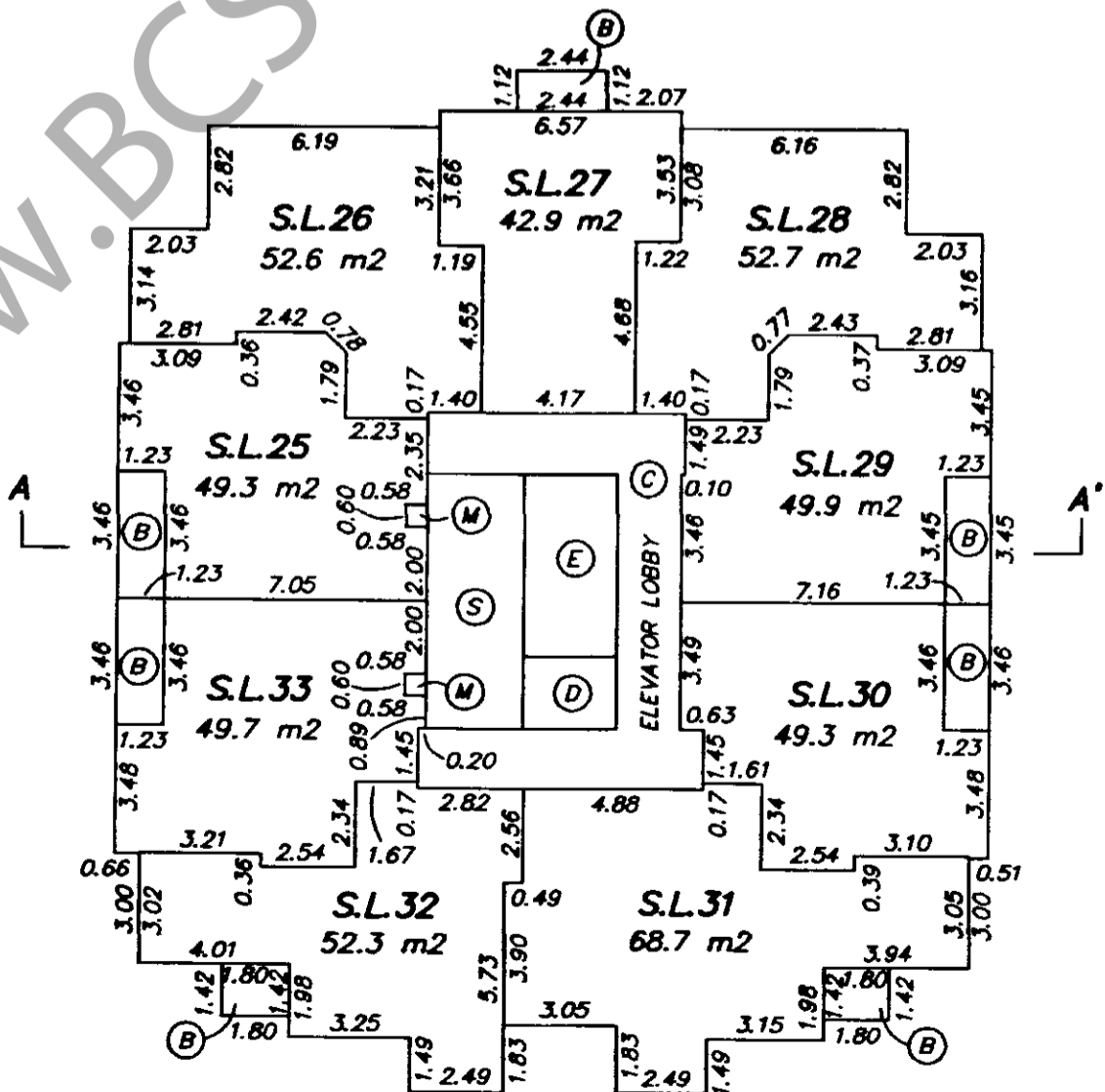
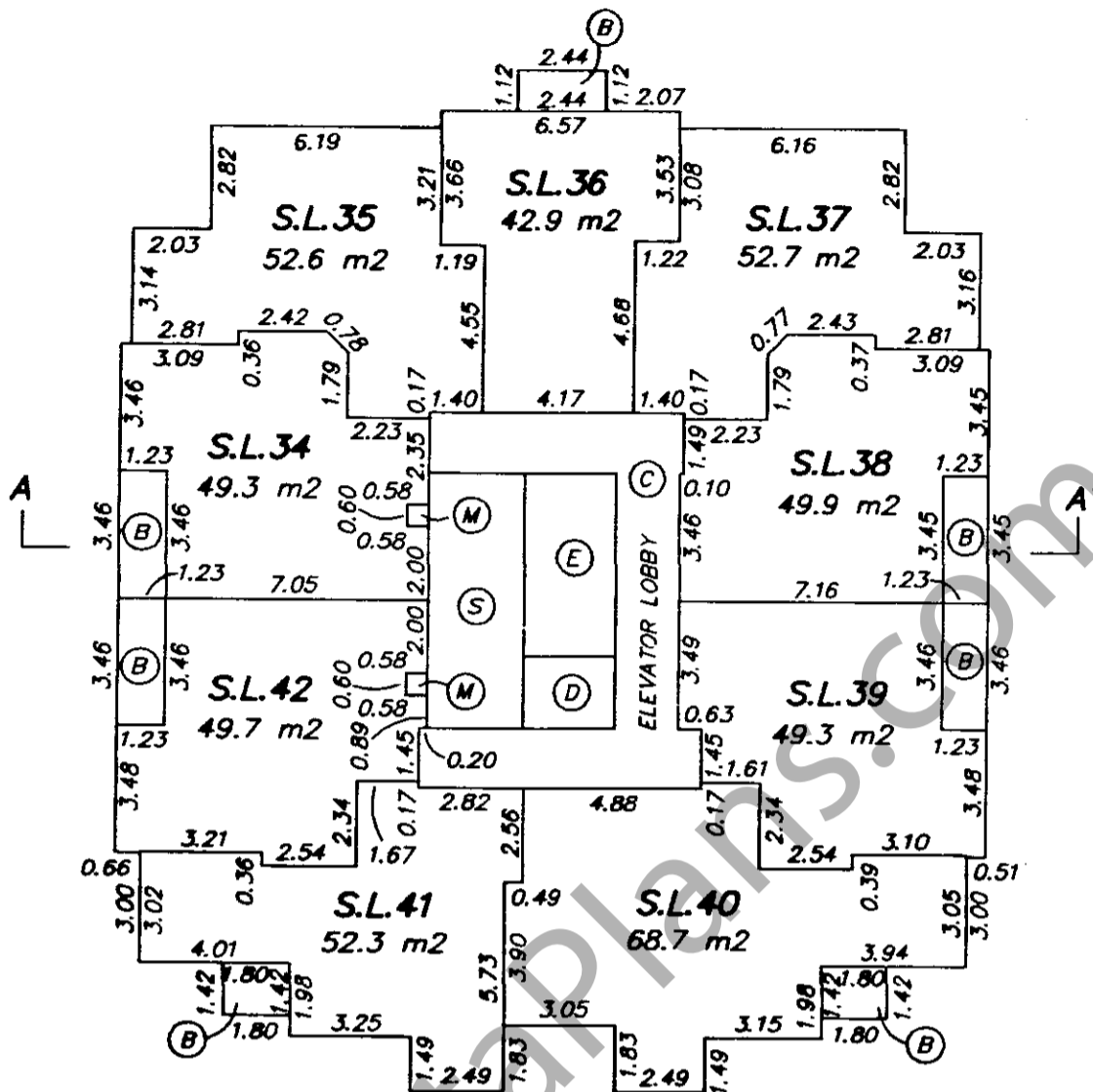

OCTOBER 7, 2003
FILE: 2616-S13

ORIGINAL

FILED
VBCS552
S32034 2005-12-01-13.28.43.118806

FLOOR PLANS

STRATA PLAN BCS 552

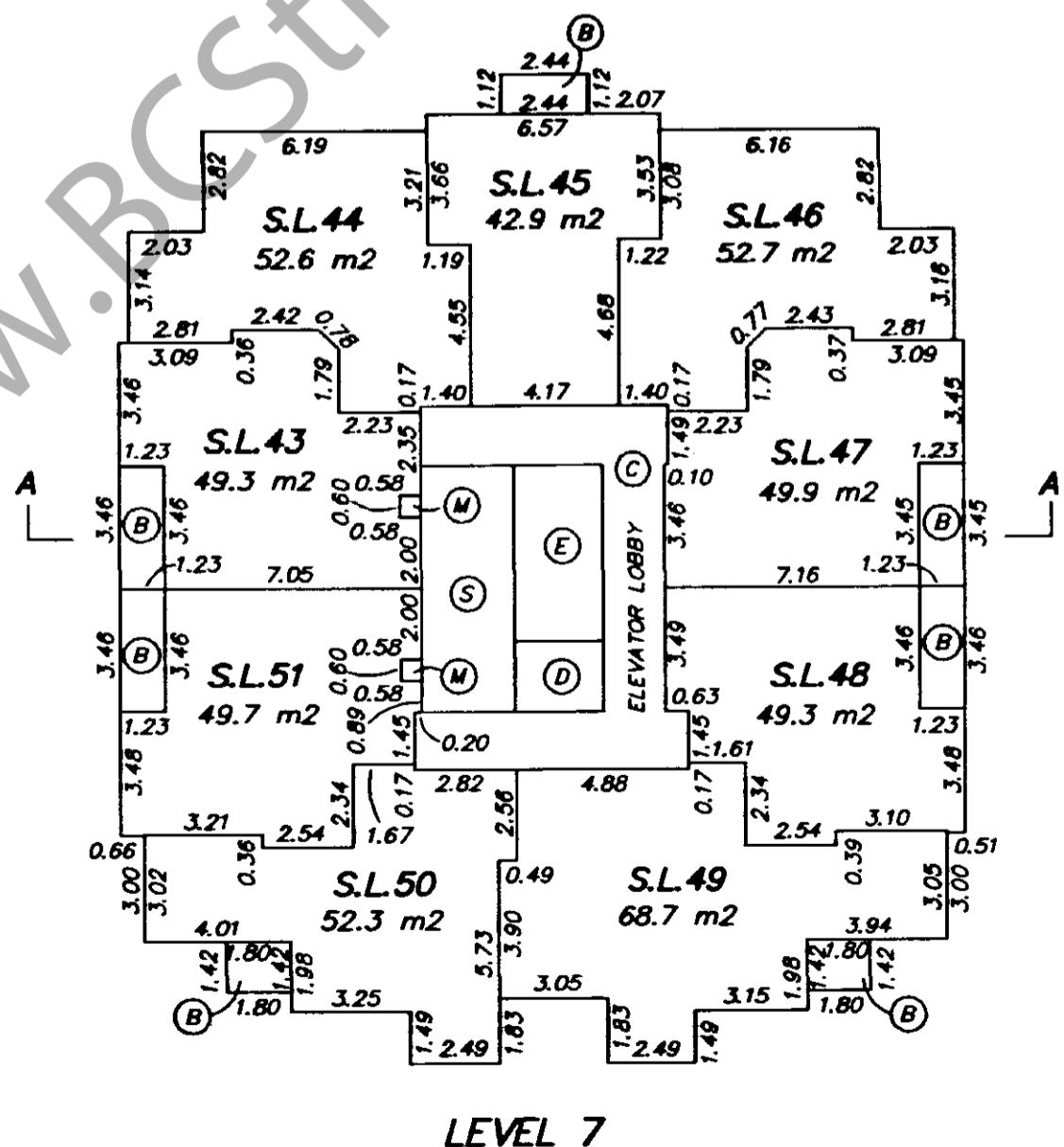
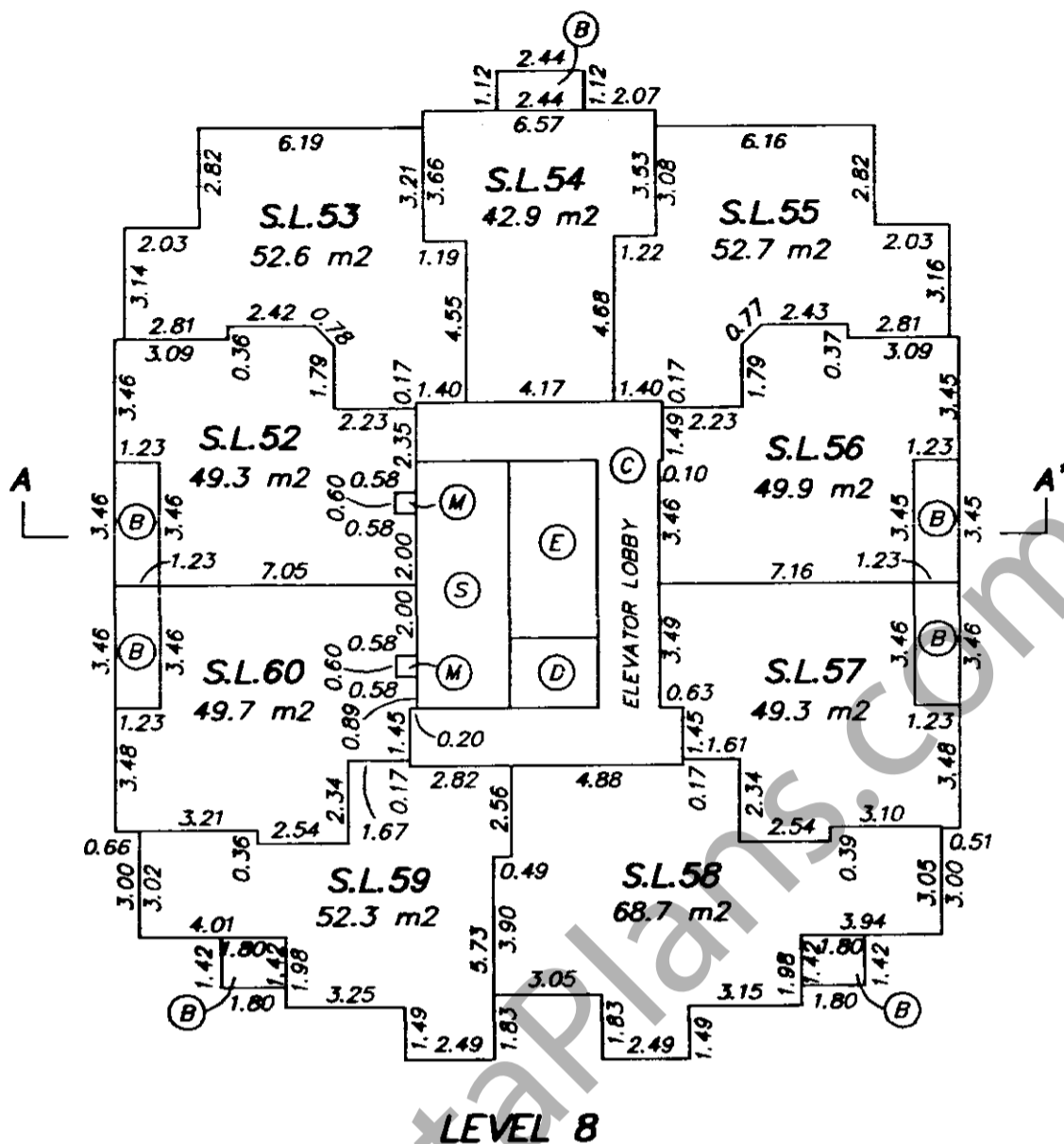

OCTOBER 7, 2003
FILE: 2616-S13

ORIGINAL

S32034 2005-12-01-13.28.43.118806
VABCS552
FILED

FLOOR PLANS

STRATA PLAN BCS 552



SCALE 1:200 DISTANCES ARE METRIC

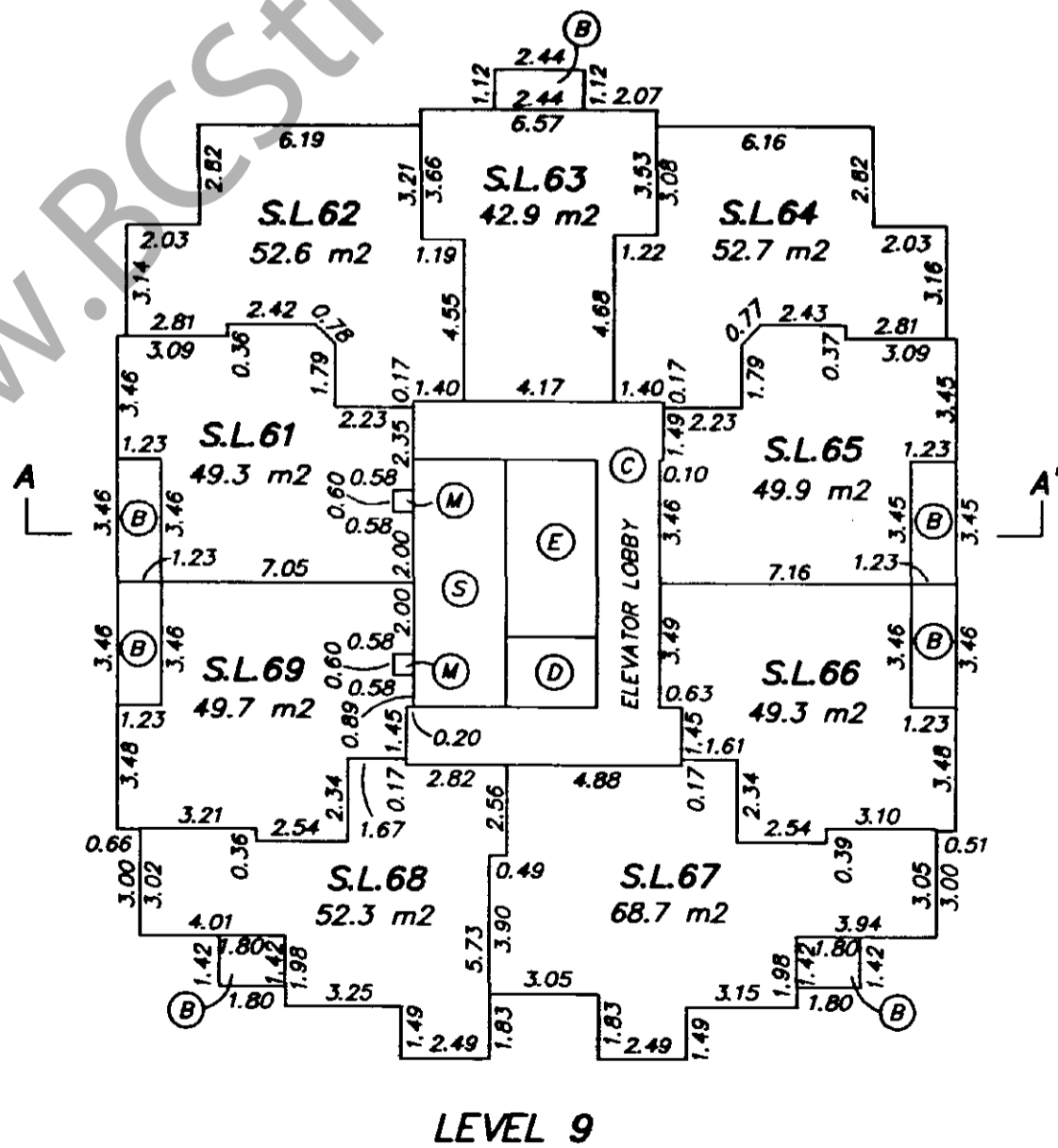
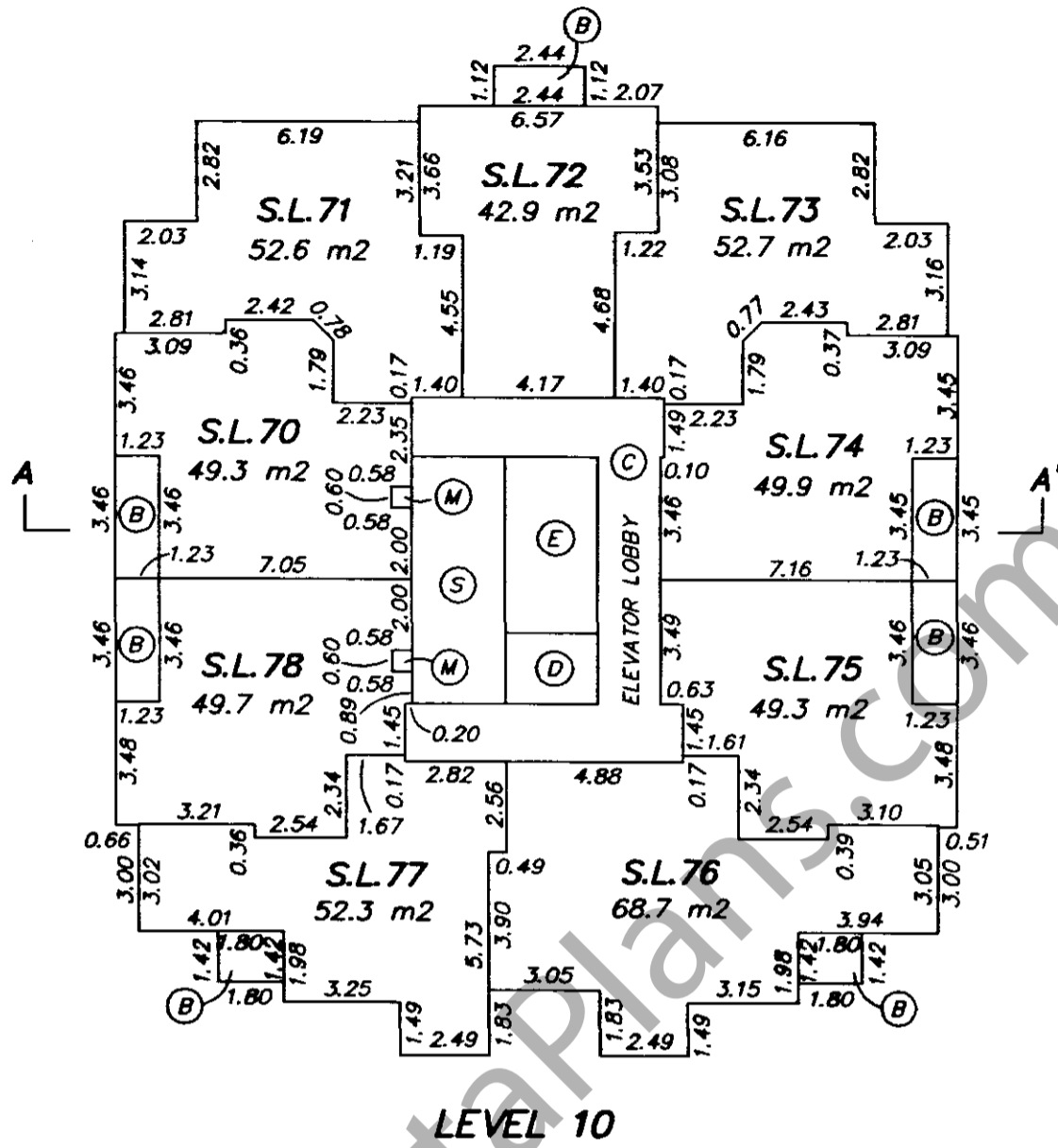

OCTOBER 7, 2003
FILE: 2616-S13

ORIGINAL

S32034 2005-12-01-13.28.43.118806
VABCS552
FILED

FLOOR PLANS

STRATA PLAN BCS 552



SCALE 1:200 DISTANCES ARE METRIC

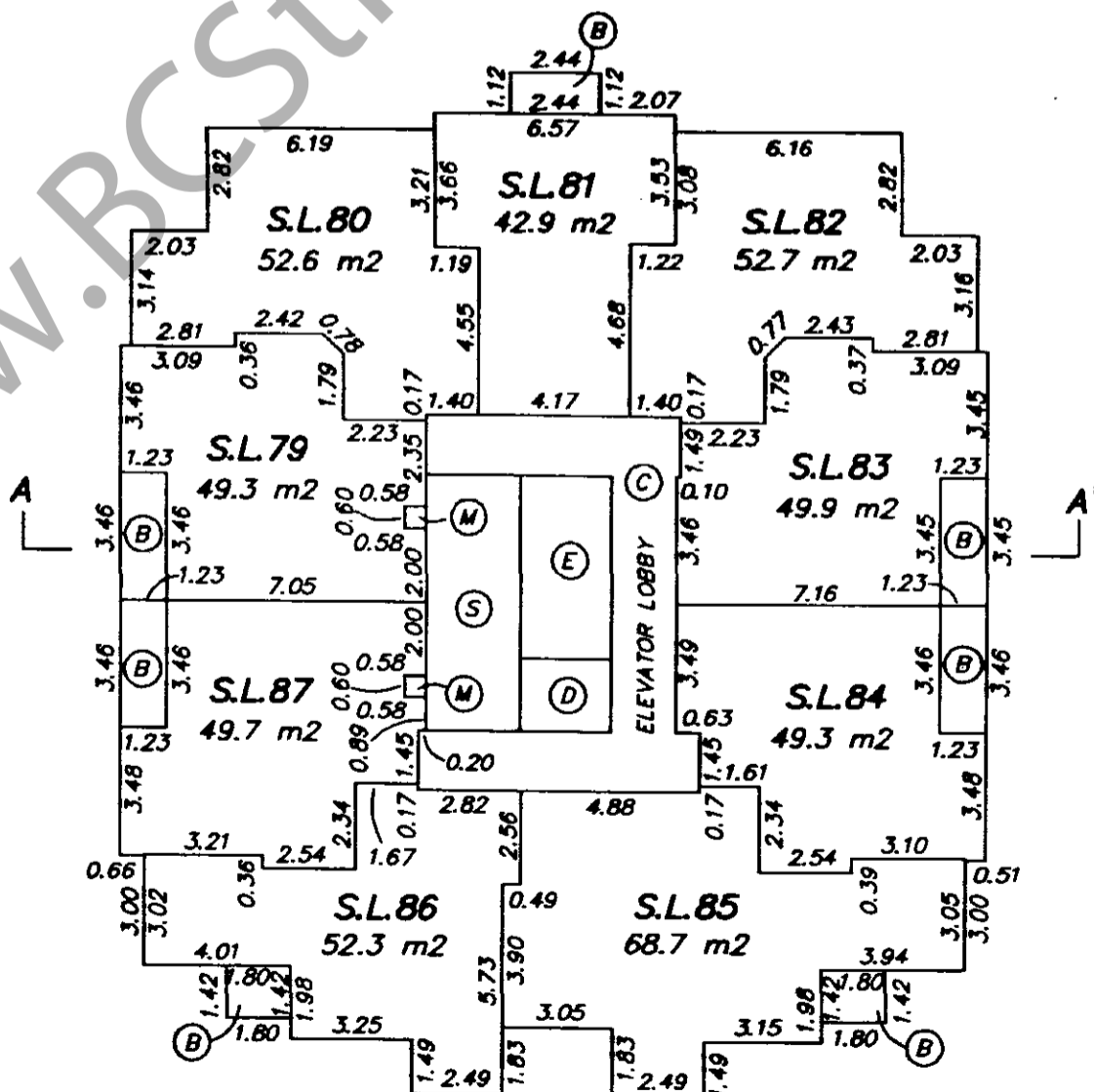
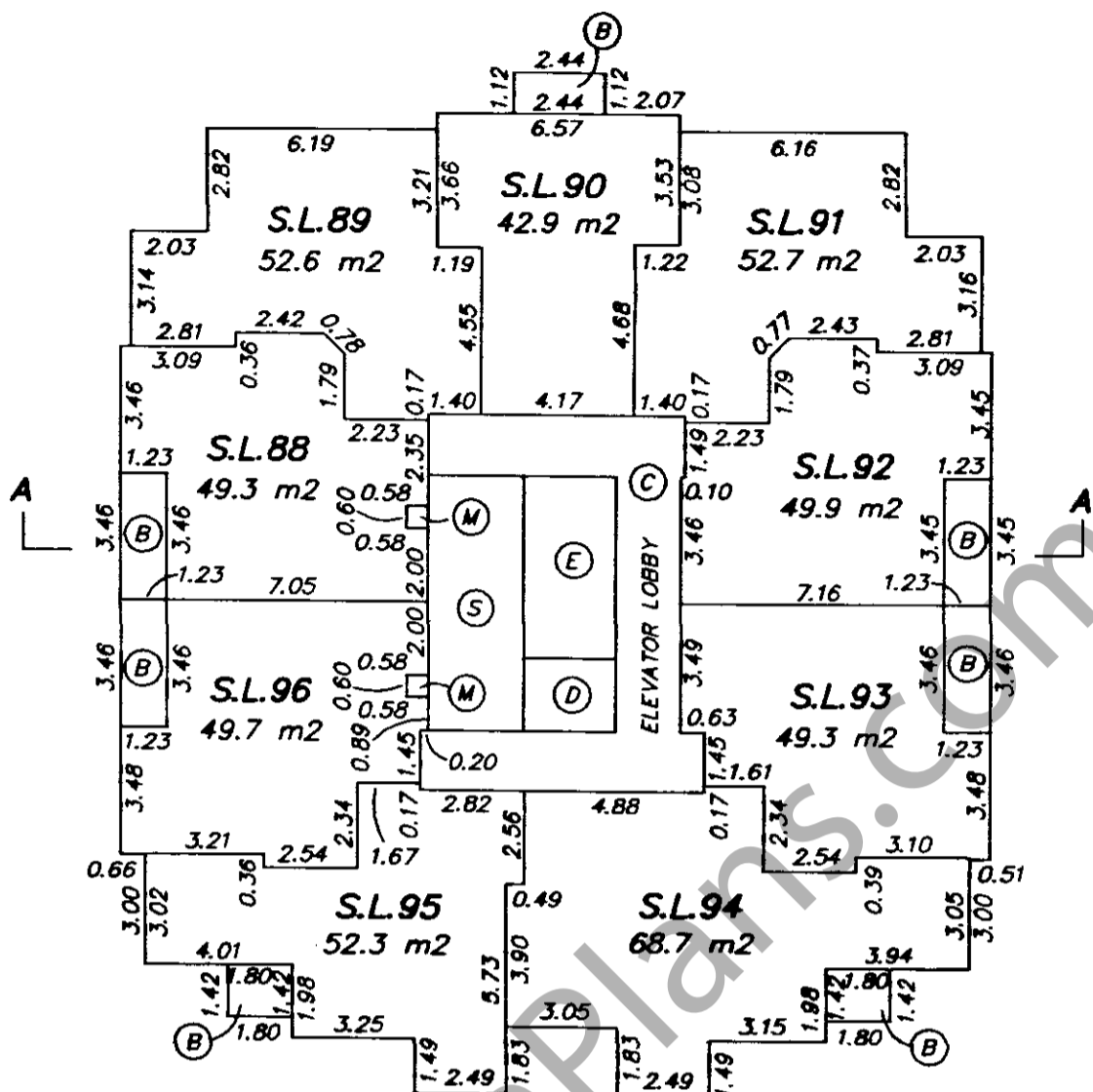

OCTOBER 7, 2003
FILE: 2616-S13

ORIGINAL

FILED VABCS552 S32034 2005-12-01-13.28.43.118806

FLOOR PLANS

STRATA PLAN BCS 552

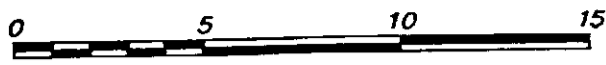

SCALE 1:200 DISTANCES ARE METRIC

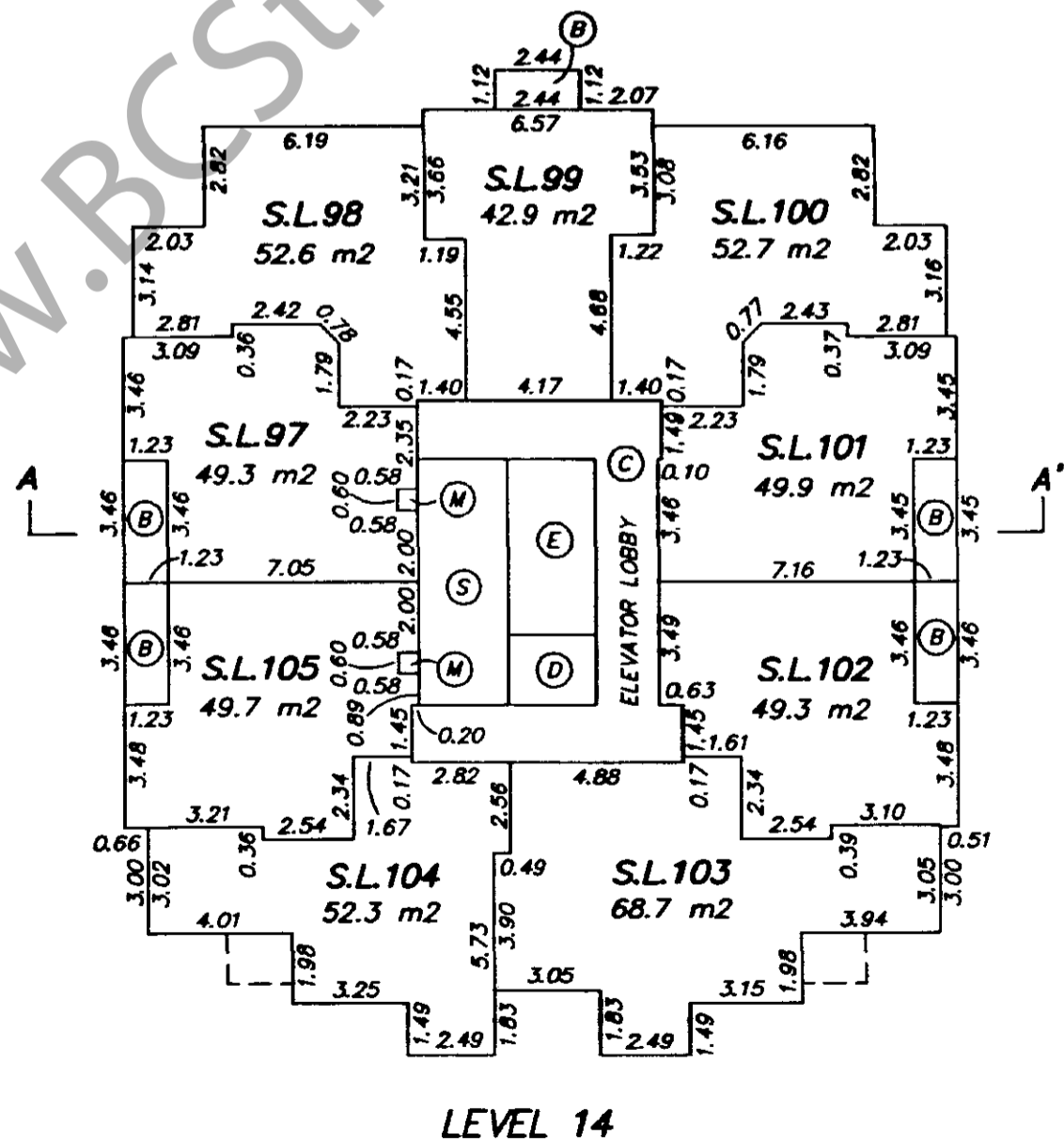
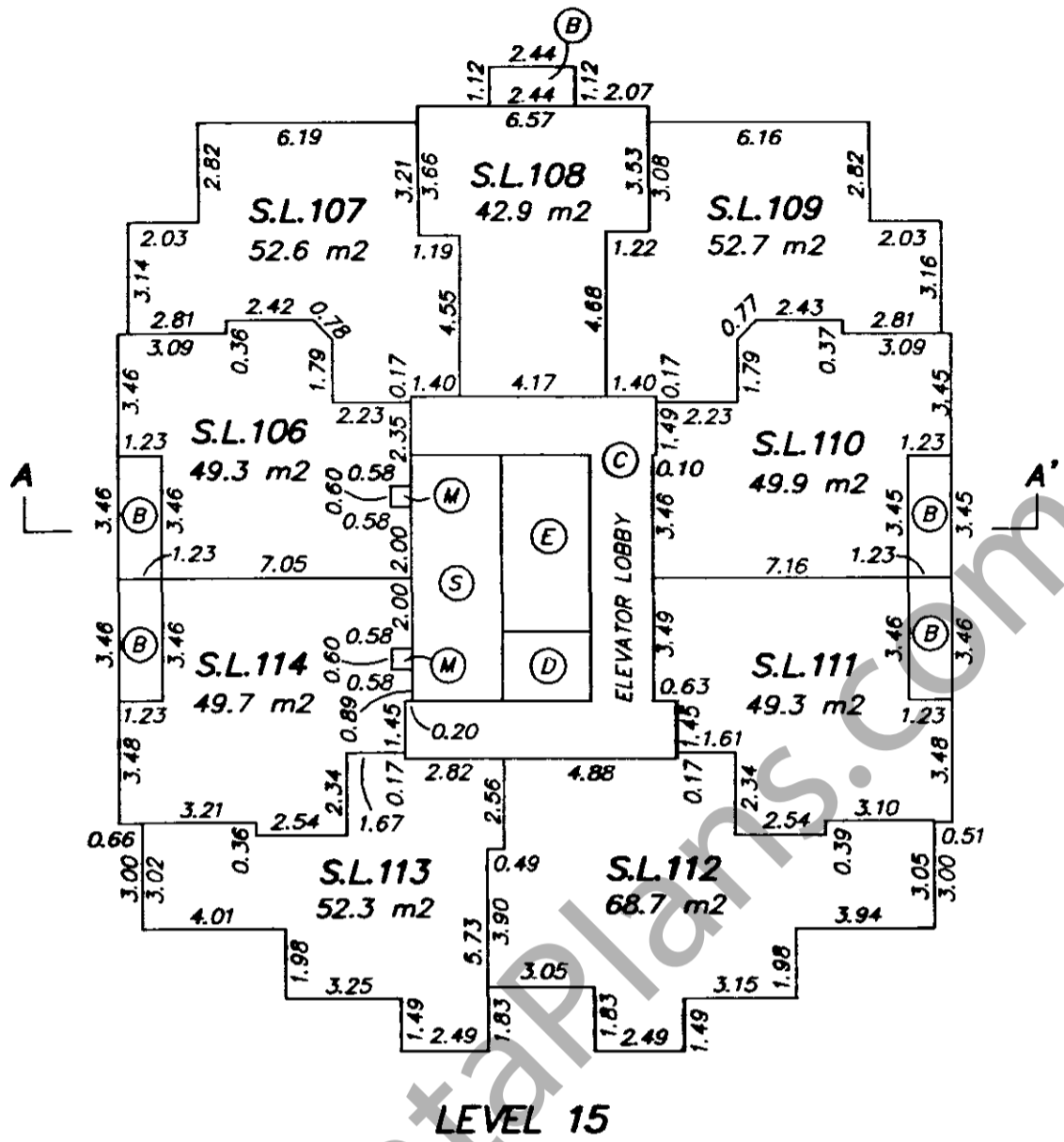

NOTE: LEVEL 13 HAS BEEN ELIMINATED FROM CONSECUTIVE FLOOR NUMBERING

OCTOBER 7, 2003
FILE: 2616-S13

ORIGINAL

S32034 2005-12-01-13.28.43.118806
VABCS552
FILED

FLOOR PLANS

STRATA PLAN BCS 552



SCALE 1:200 DISTANCES ARE METRIC

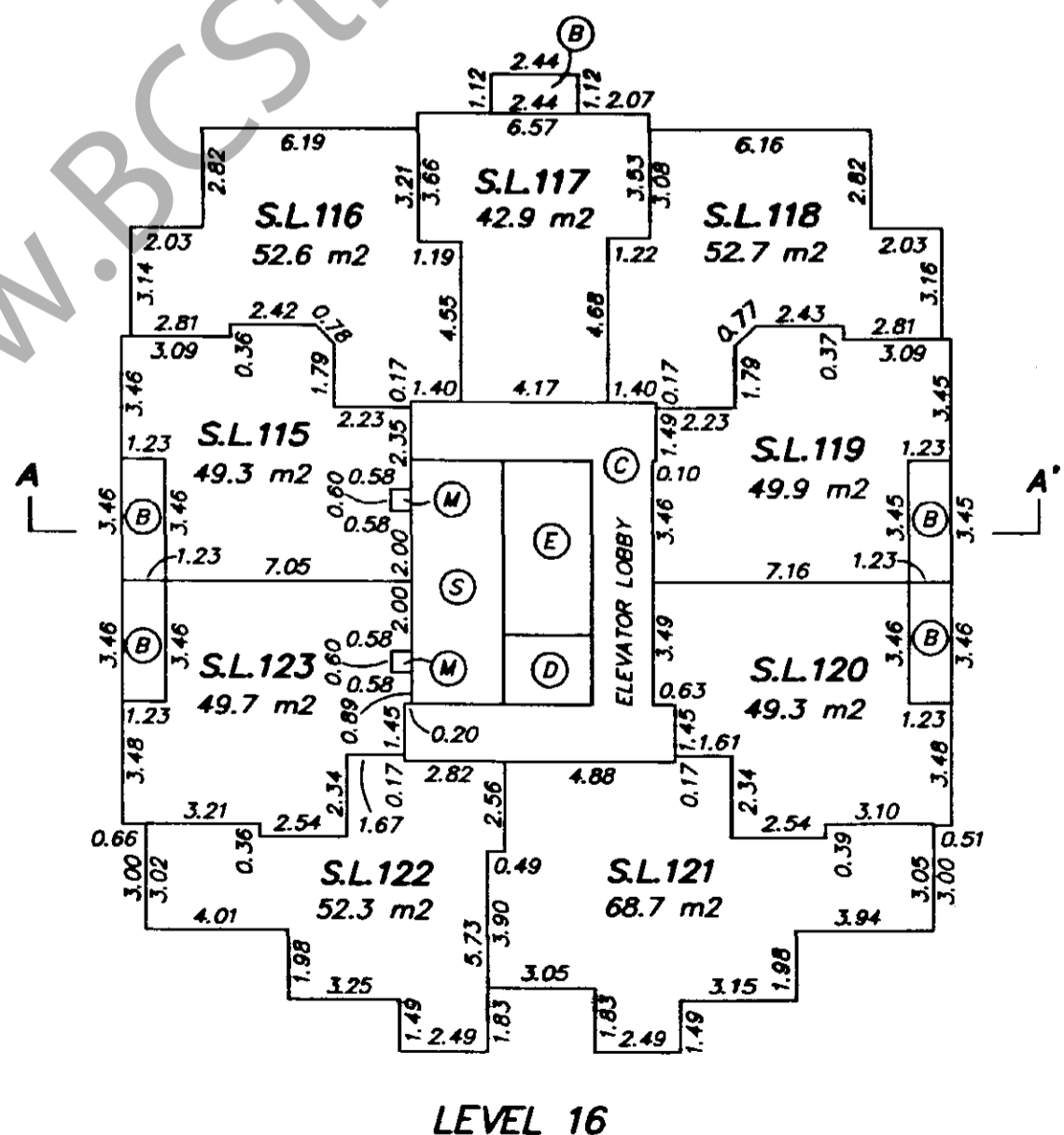
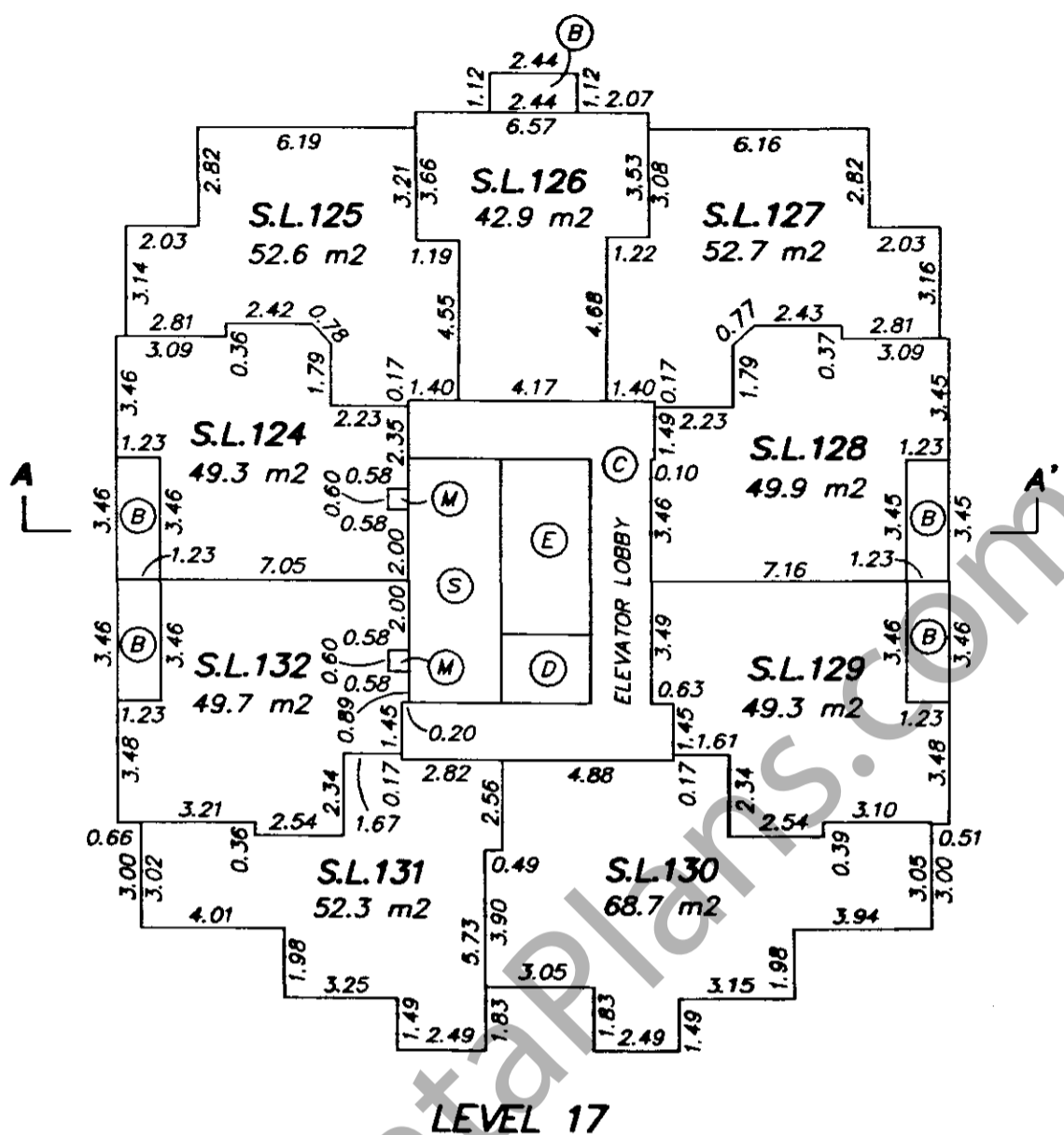

WWW.BCStrataPlans.com

[Signature]

OCTOBER 7, 2003
FILE: 2616-S13

ORIGINAL

S32034 2005-12-01-13.28.43.118806
VABCS552
FILED

FLOOR PLANS

STRATA PLAN BCS 552



SCALE 1:200 DISTANCES ARE METRIC

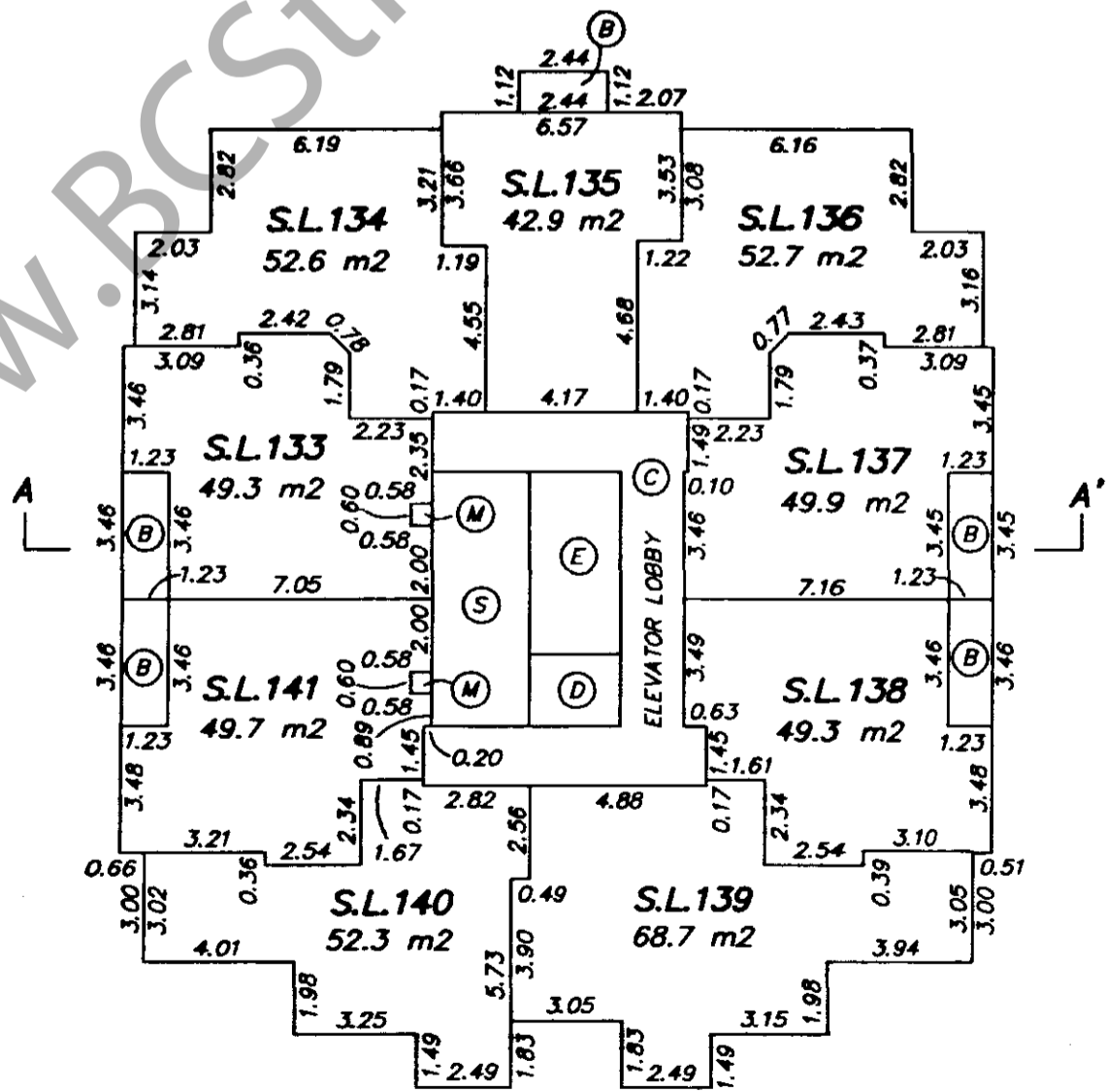
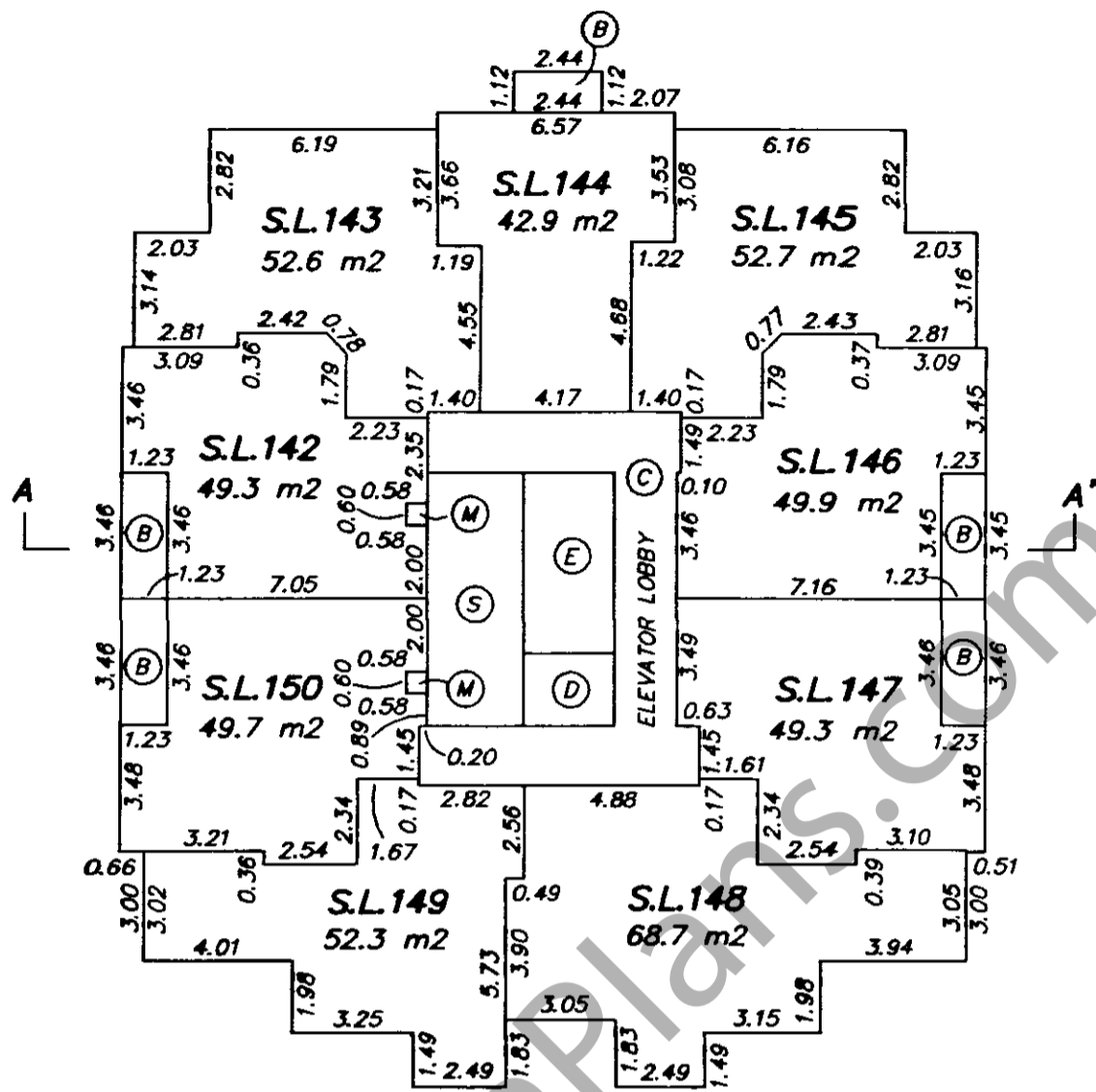

OCTOBER 7, 2003
FILE: 2616-S13

ORIGINAL

FILED S32034 2005-12-01-13.28.43.118806 VABCS552

FLOOR PLANS

STRATA PLAN BCS 552

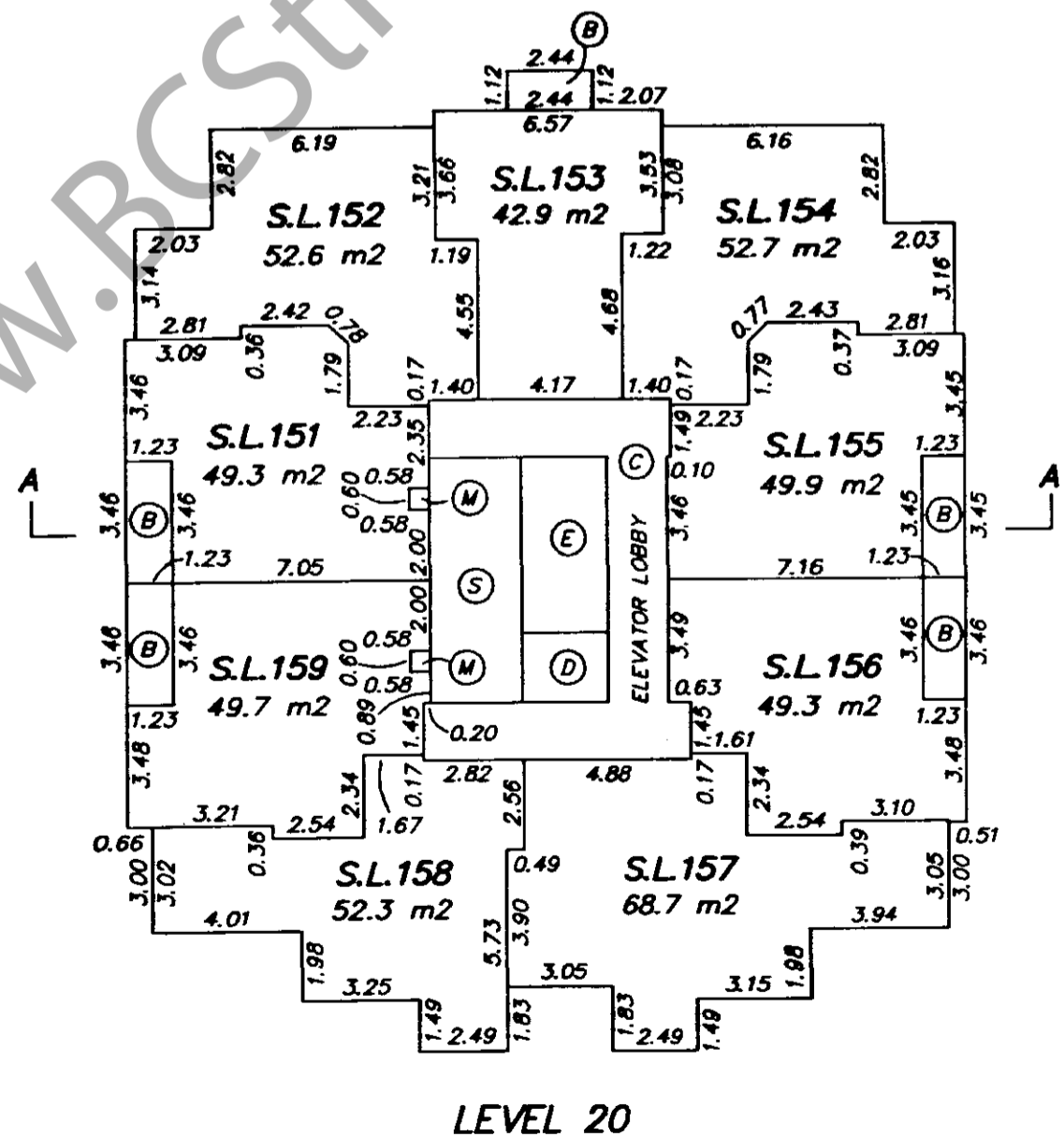
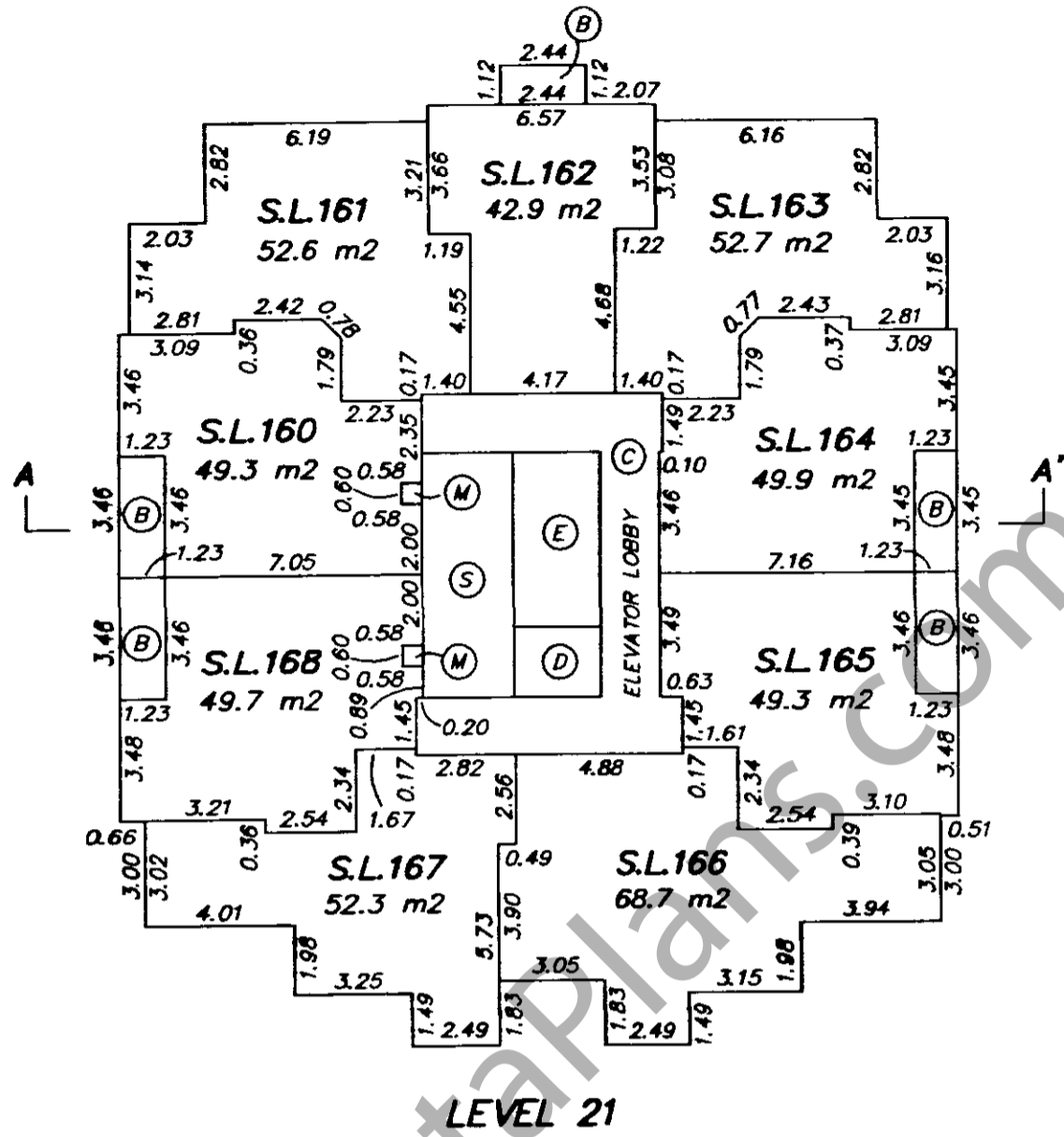

OCTOBER 7, 2003
FILE: 2616-S13

ORIGINAL

S32034 2005-12-01-13.28.43.118806
VABCS552
FILED

FLOOR PLANS

STRATA PLAN BCS 332



SCALE 1:200 DISTANCES ARE METRIC

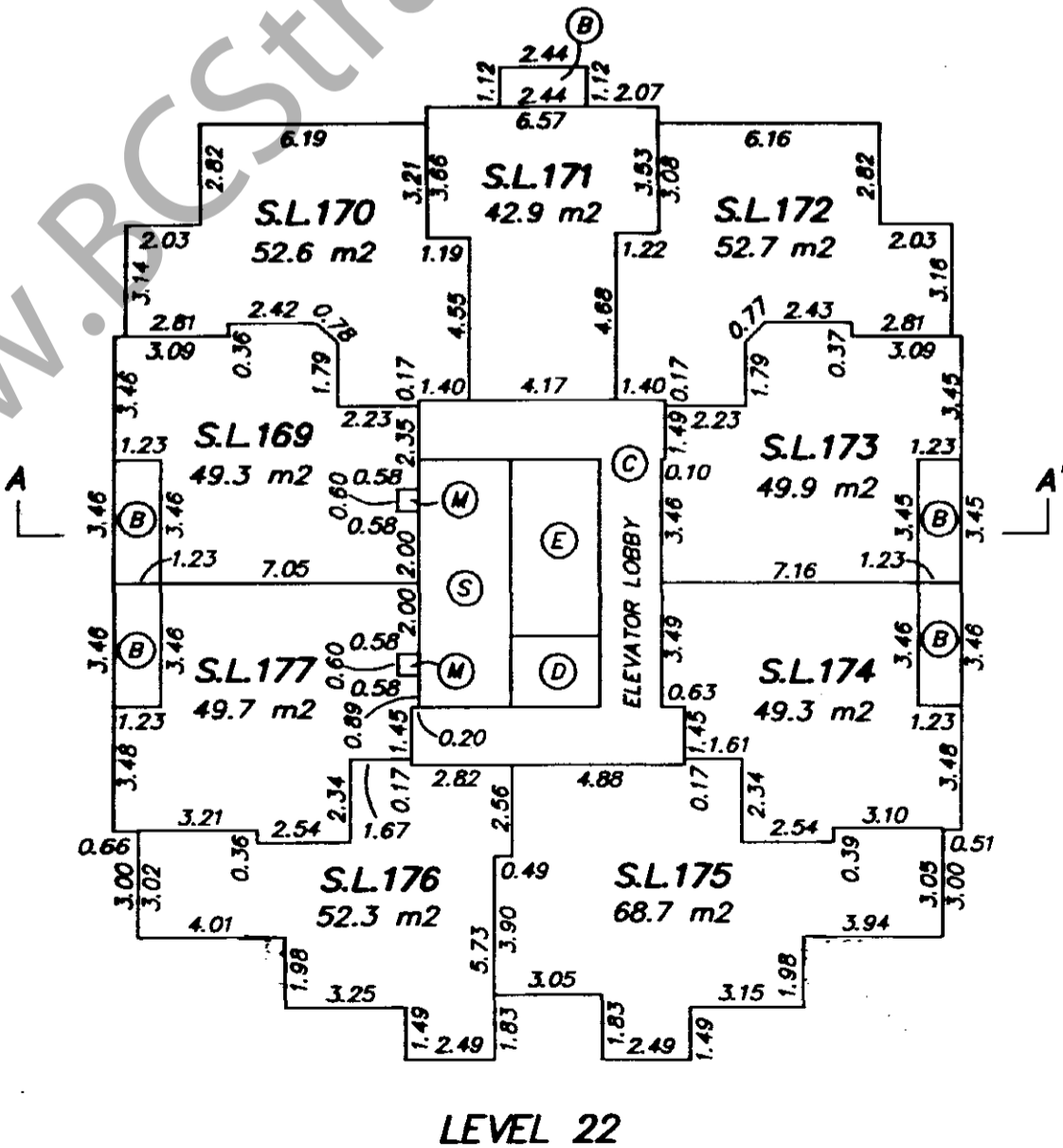
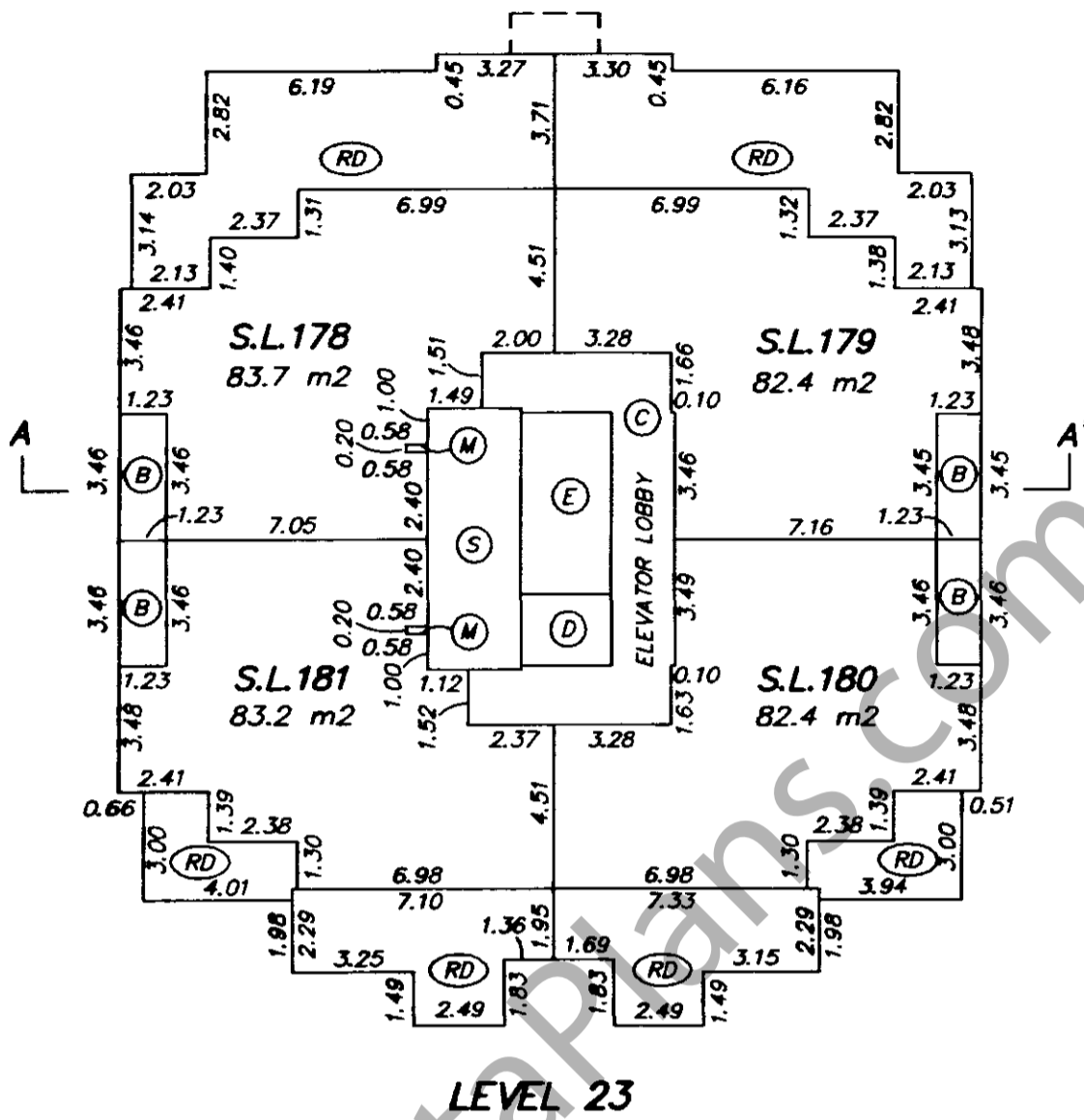

OCTOBER 7, 2003
FILE: 2616-S13

ORIGINAL

FILED VBCS552 S32034 2005-12-01-13.28.43.118806

FLOOR PLANS

STRATA PLAN BCS 552



SCALE 1:200 DISTANCES ARE METRIC

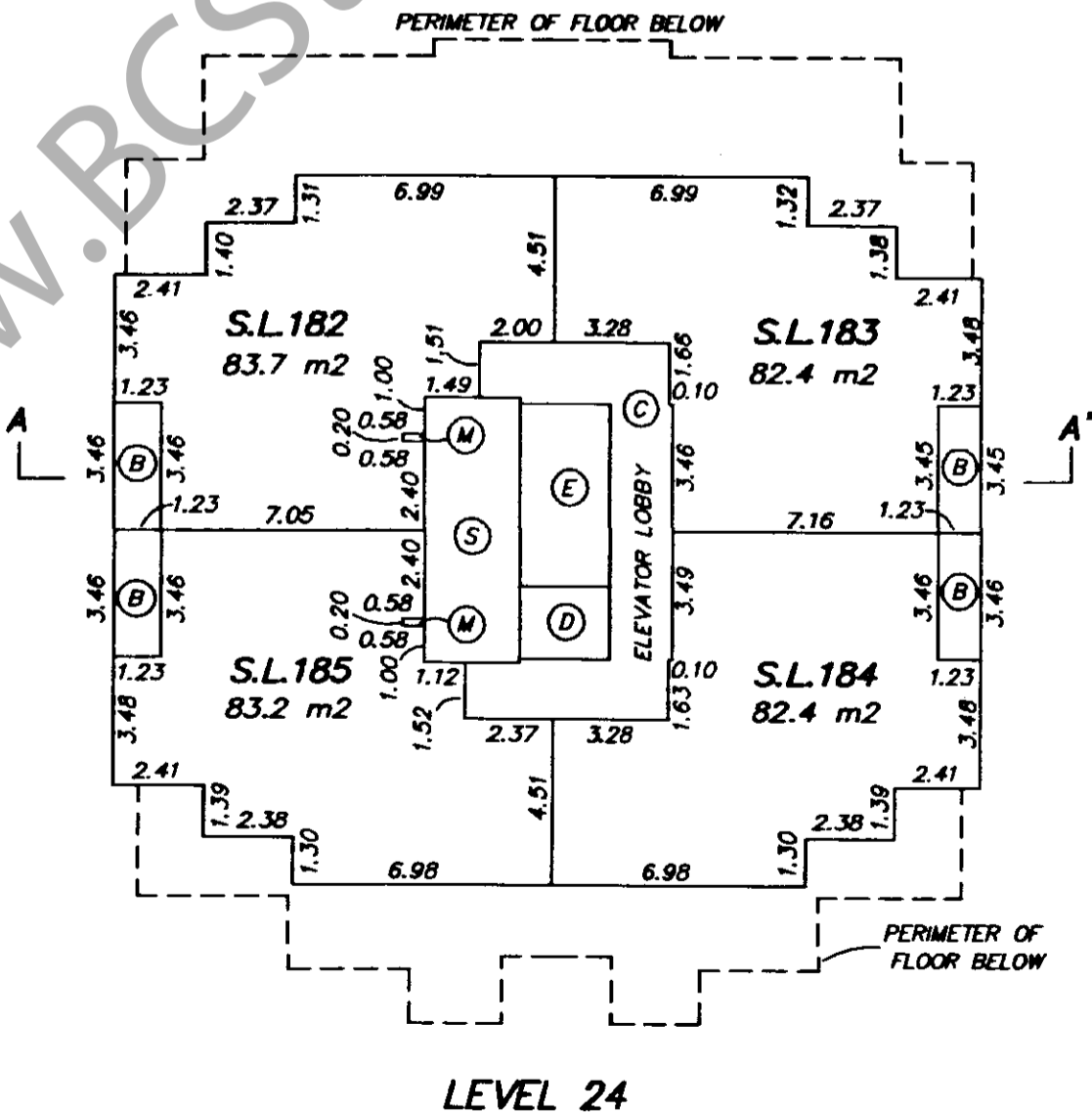
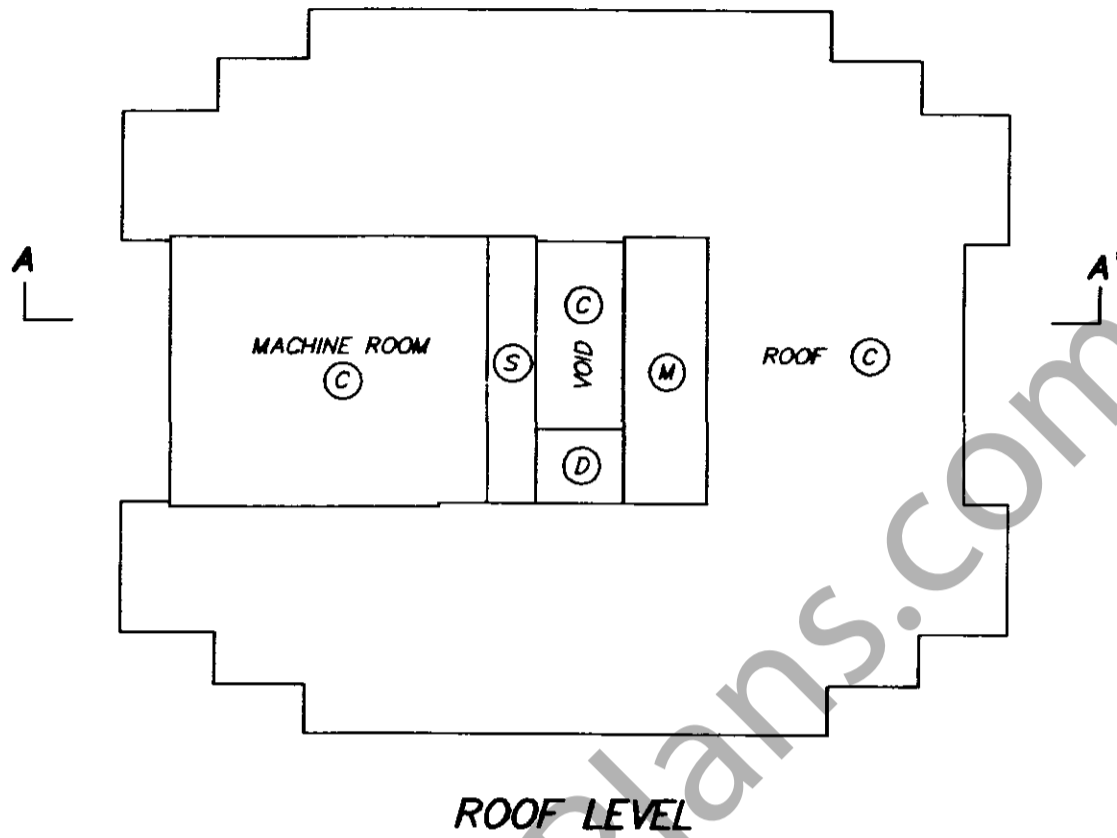

OCTOBER 7, 2003
FILE: 2616-S13

ORIGINAL

FILED S32034 2005-12-01-13.28.43.118806 VABCS552

SECTION A - A'

STRATA PLAN BCS 552



(SEE SHEET 23 FOR CONTINUATION)

LEVEL 10	(B)	S.L. 70				S.L. 74	(B)
LEVEL 9	(B)	S.L. 61				S.L. 65	(B)
LEVEL 8	(B)	S.L. 52				S.L. 56	(B)
LEVEL 7	(B)	S.L. 43	(S)	(E)	(C)	S.L. 47	(B)
LEVEL 6	(B)	S.L. 34			ELEVATOR	S.L. 38	(B)
LEVEL 5	(B)	S.L. 25				LOBBY	S.L. 29
LEVEL 4	(B)	S.L. 16				S.L. 20	(B)
LEVEL 3	(B)	S.L. 7				S.L. 11	(B)
LEVEL 2						S.L. 6	
UPPER GROUND LEVEL		ENTRY (C)				AMENITY ROOM (C)	
							LOWER GROUND LEVEL
LEVEL P1		EXPLANATORY PLAN BCP 2238				EXPLANATORY PLAN BCP 2238	
LEVEL P2		EXPLANATORY PLAN BCP 2239				EXPLANATORY PLAN BCP 2239	
LEVEL P3		EXPLANATORY PLAN BCP 2240				EXPLANATORY PLAN BCP 2240	

OCTOBER 7, 2003
FILE: 2616-S13

ORIGINAL

FILED S32034 2005-12-01-13.28.43.118806 VABCS552

SECTION A - A'

STRATA PLAN BCS 552



SCALE 1:200 DISTANCES ARE METRIC

		MACHINE ROOM (C)	(S)	VOID (C)	(M)	
ROOF						
LEVEL 24	(B)	S.L. 182				S.L. 183 (B)
LEVEL 23	(B)	S.L. 178				S.L. 179 (B)
LEVEL 22	(B)	S.L. 169				S.L. 173 (B)
LEVEL 21	(B)	S.L. 160				S.L. 164 (B)
LEVEL 20	(B)	S.L. 151				S.L. 155 (B)
LEVEL 19	(B)	S.L. 142				S.L. 146 (B)
LEVEL 18	(B)	S.L. 133				S.L. 137 (B)
LEVEL 17	(B)	S.L. 124				S.L. 128 (B)
LEVEL 16	(B)	S.L. 115	(S)	(E)	(C)	S.L. 119 (B)
LEVEL 15	(B)	S.L. 106				S.L. 110 (B)
LEVEL 14	(B)	S.L. 97			LOBBY	S.L. 101 (B)
LEVEL 12	(B)	S.L. 88			ELEVATOR	S.L. 92 (B)
LEVEL 11	(B)	S.L. 79				S.L. 83 (B)
LEVEL 10	(B)	S.L. 70				S.L. 74 (B)
LEVEL 9		S.L. 61				S.L. 65

(SEE SHEET 22 FOR CONTINUATION)

OCTOBER 7, 2003
FILE: 2616-S13

ORIGINAL

FILED S32034 2005-12-01-13.28.43.118806 VABCS552